

# Flyback Power Supply

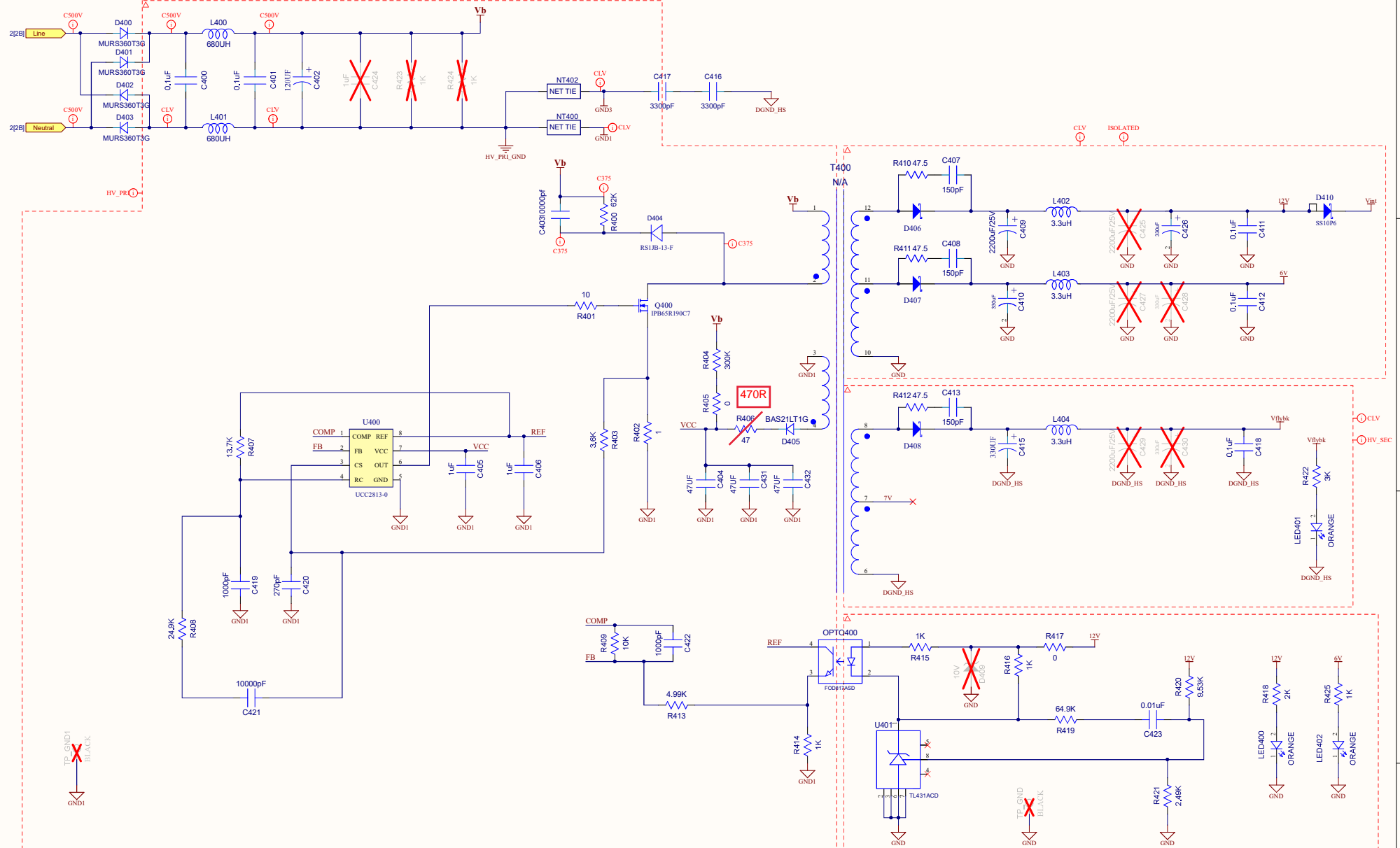

THIS DRAWING IS CONFIDENTIAL AND PROPERTY OF LIFE FITNESS



## INTEGRATED MOTOR DRIVE BOARD (IMDB)

Document Number: **1020527-0011** Schematic Variant: 1020527-0011

Drawn: Sophia Konowal 09/16/2022 Checked: Checked By Checked Date SHEET 4 OF 9 SIZE C