

Vin = 19-10.8V
 Vout = 5V
 OCP = 22.44A
 Switching Frequency = 370KHz

19-10.8V
 Iin=4.33A~7.63A
 Irms=6.16A~6.98A

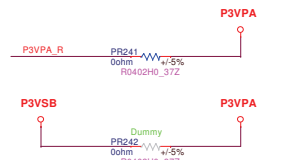

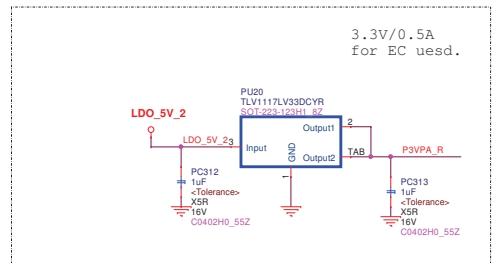
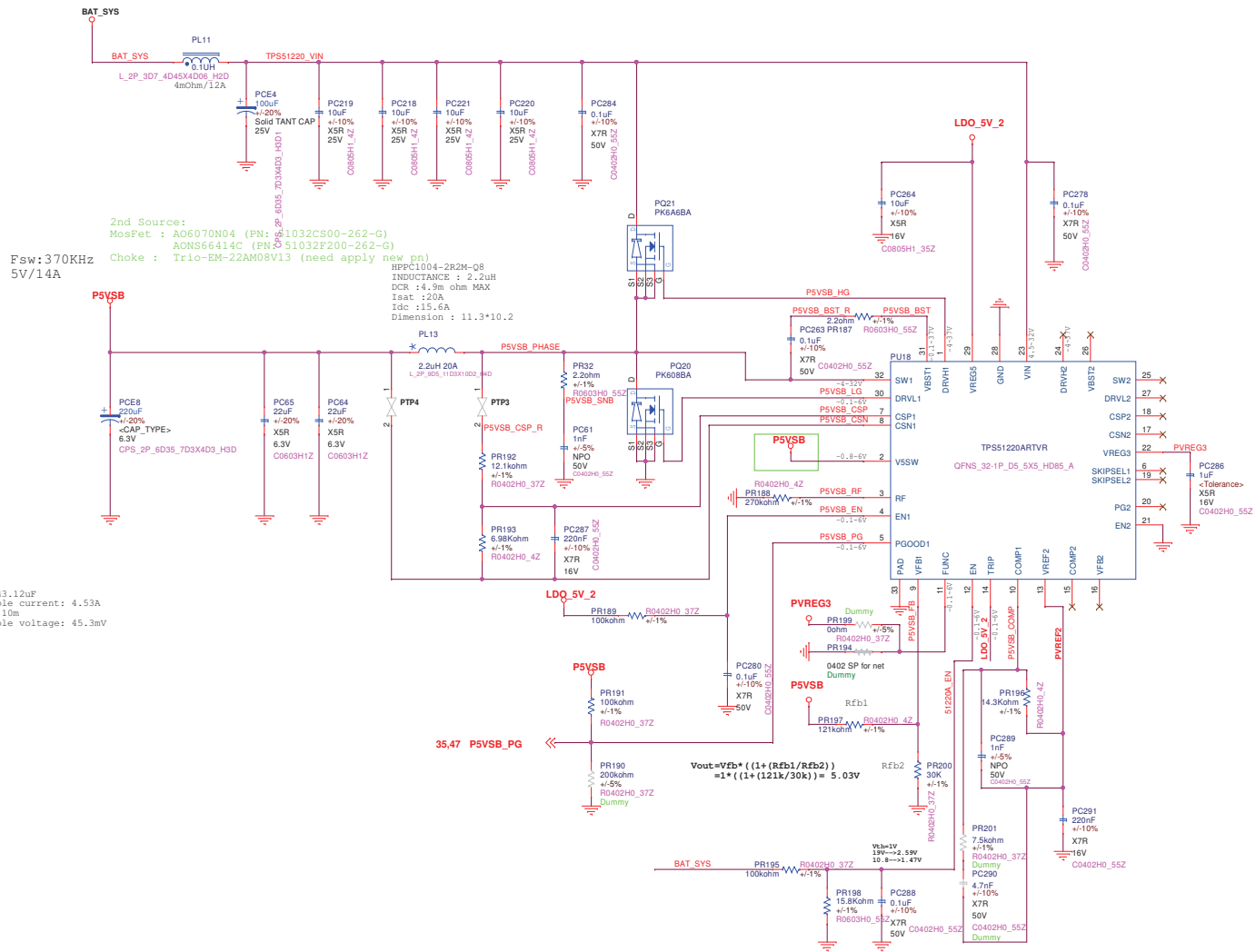
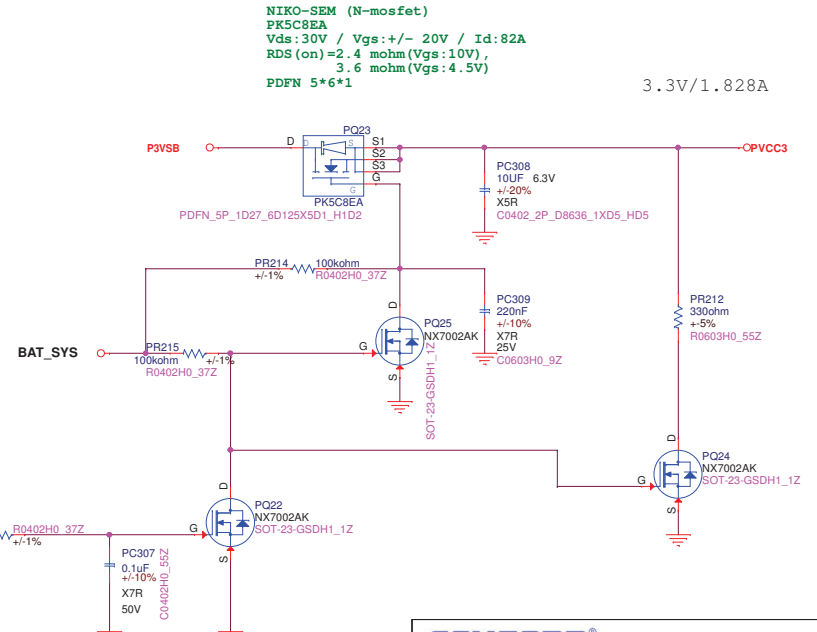
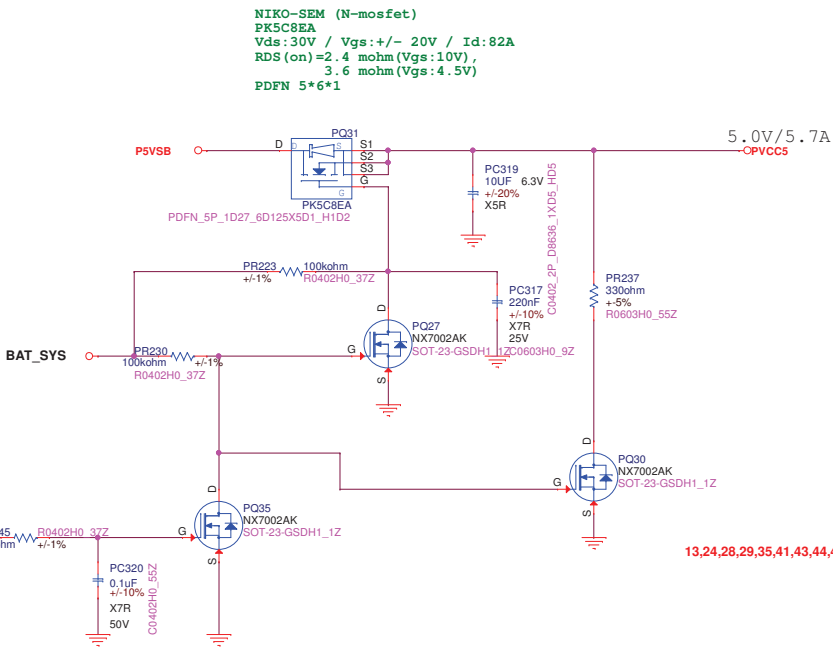
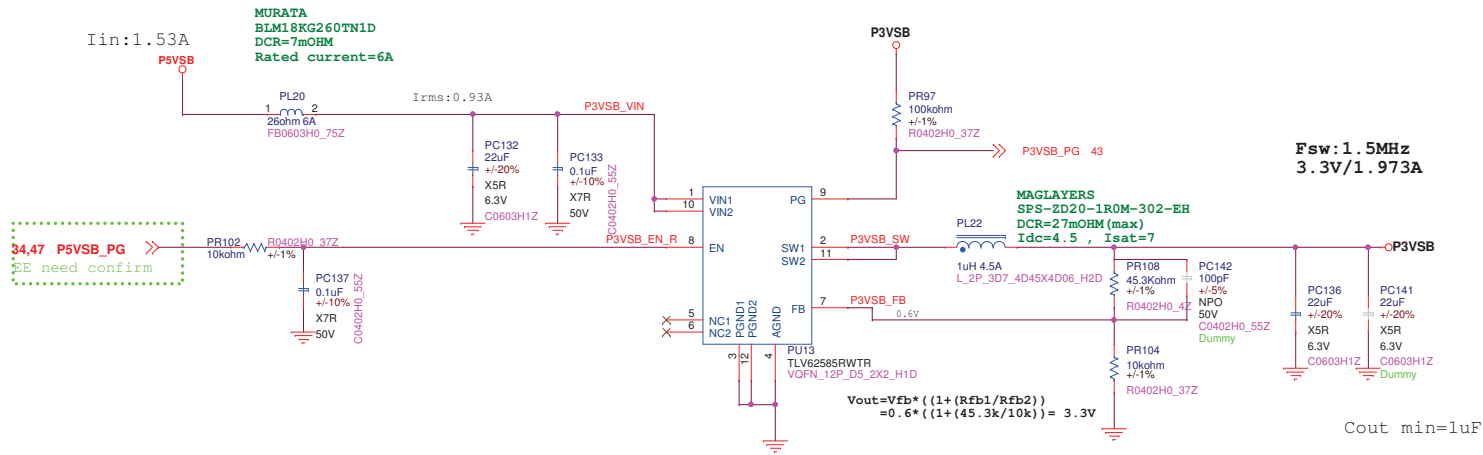

28,29,35,41,43,44,46 PM_SLP_S3_N

13,24,28,29,35,41,43,44,46 PM_SLP_S3_N

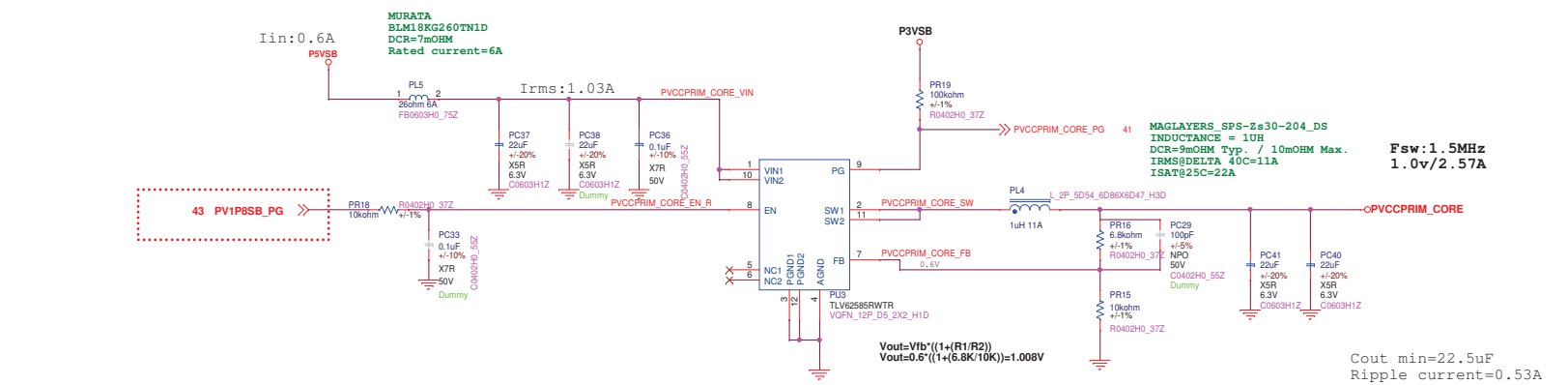
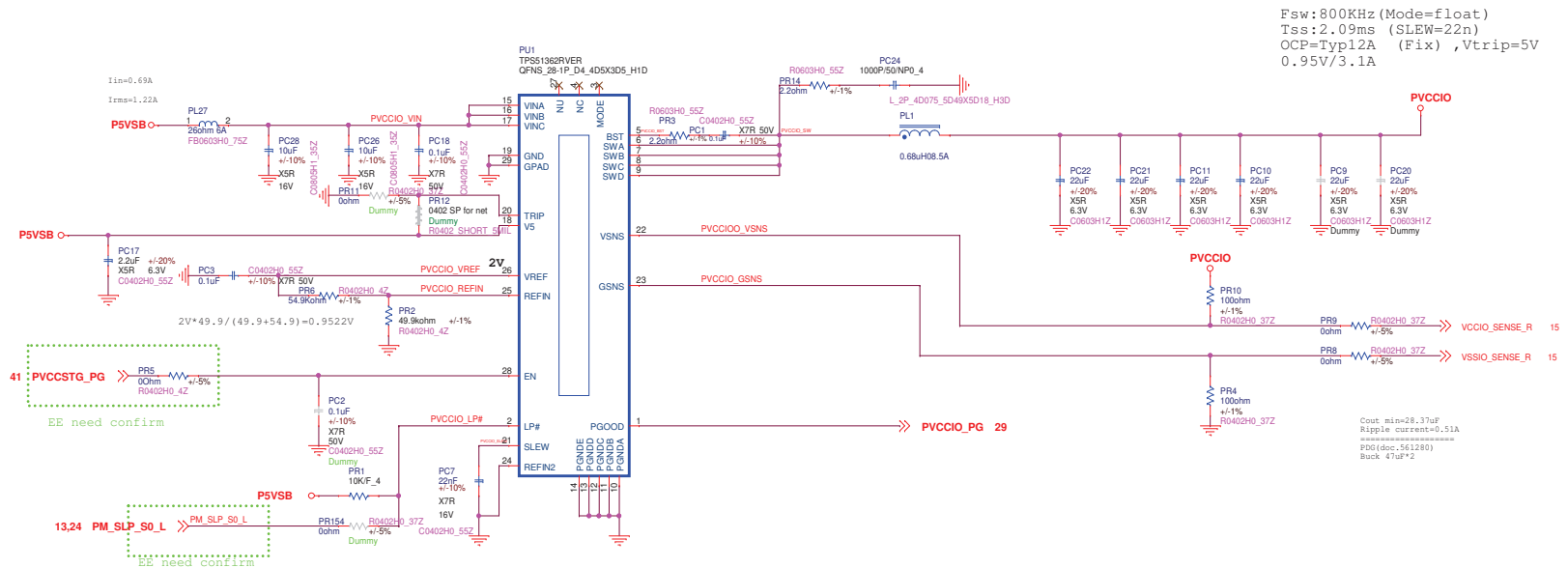

Iin=0.89A

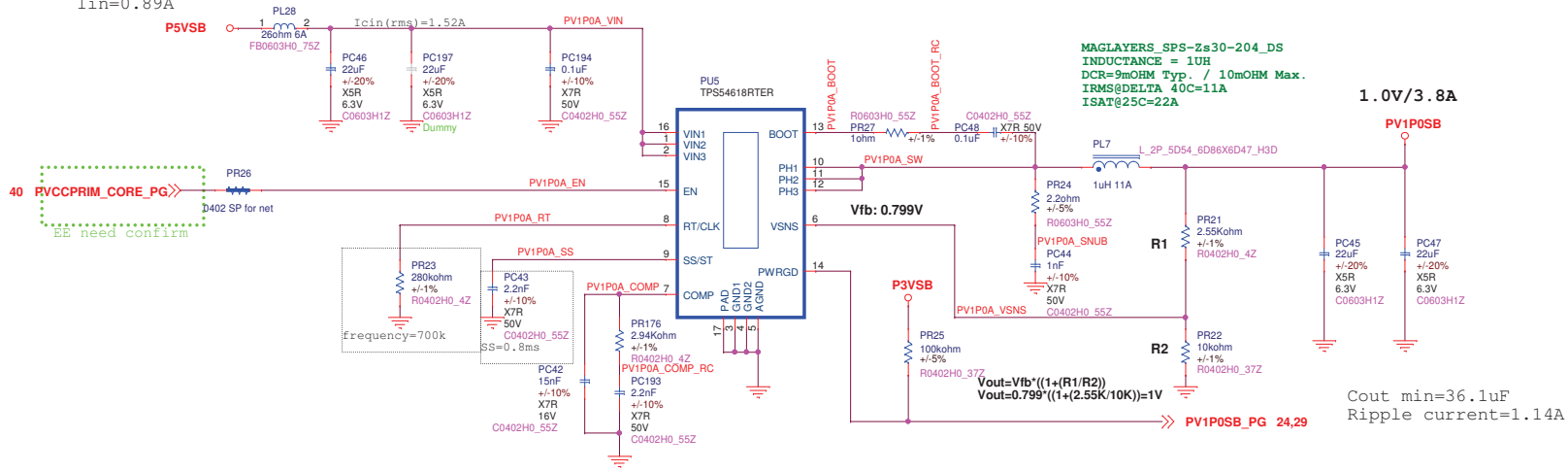

Iin=0.15A

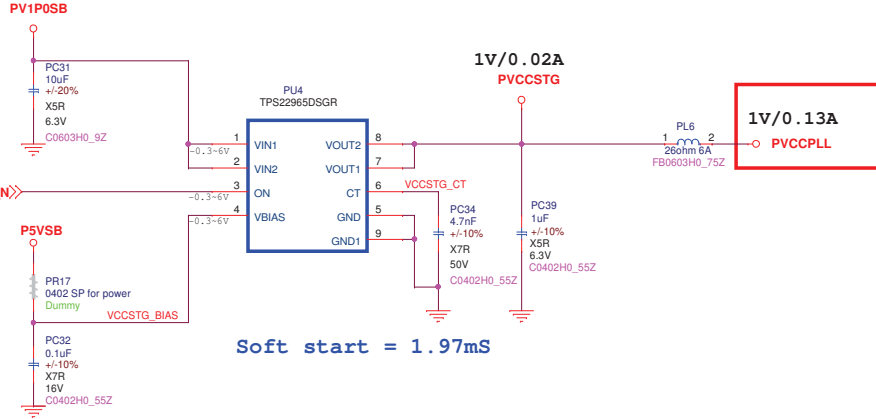

Iin=0.06A

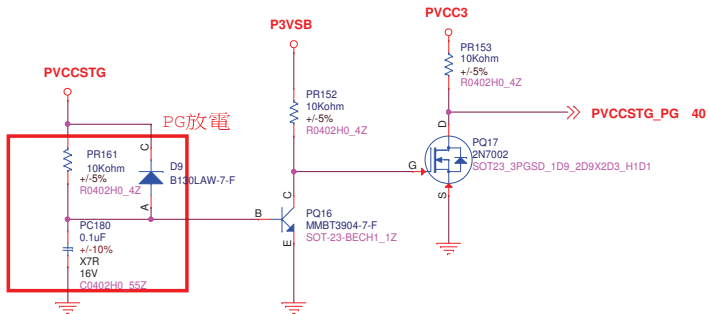
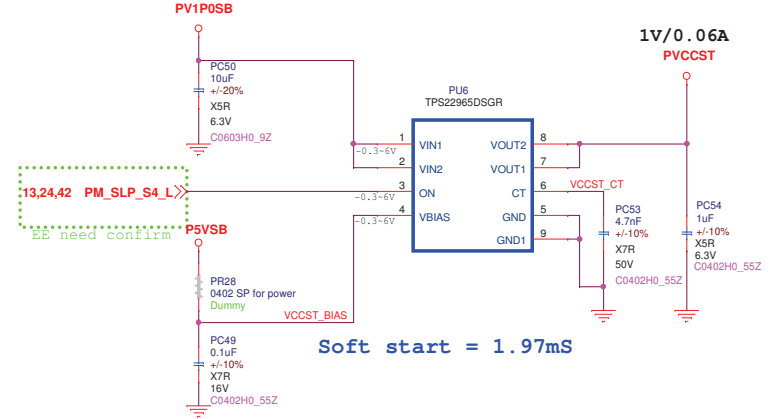

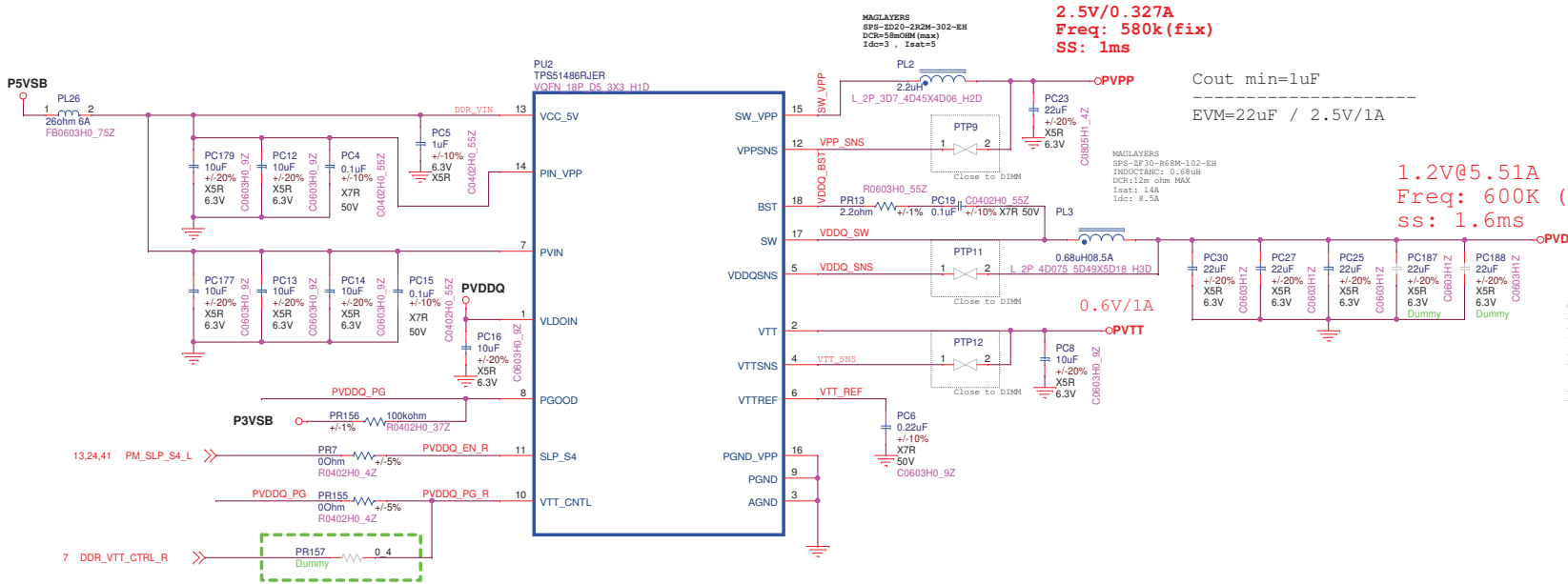

2.5V/0.327A
 Freq: 580k (fix)
 SS: 1ms

Cout min=1uF

 EVM=22uF / 2.5V/1A

1.2V@5.51A
 Freq: 600K (fix)
 ss: 1.6ms

Cout min=29.41uF
 Ripple= 2.33A

PDG(doc.561280)
 4*10uF 0402 + 3*22uF 0603
 EVM
 22uF*5 / 1.2V / 8A

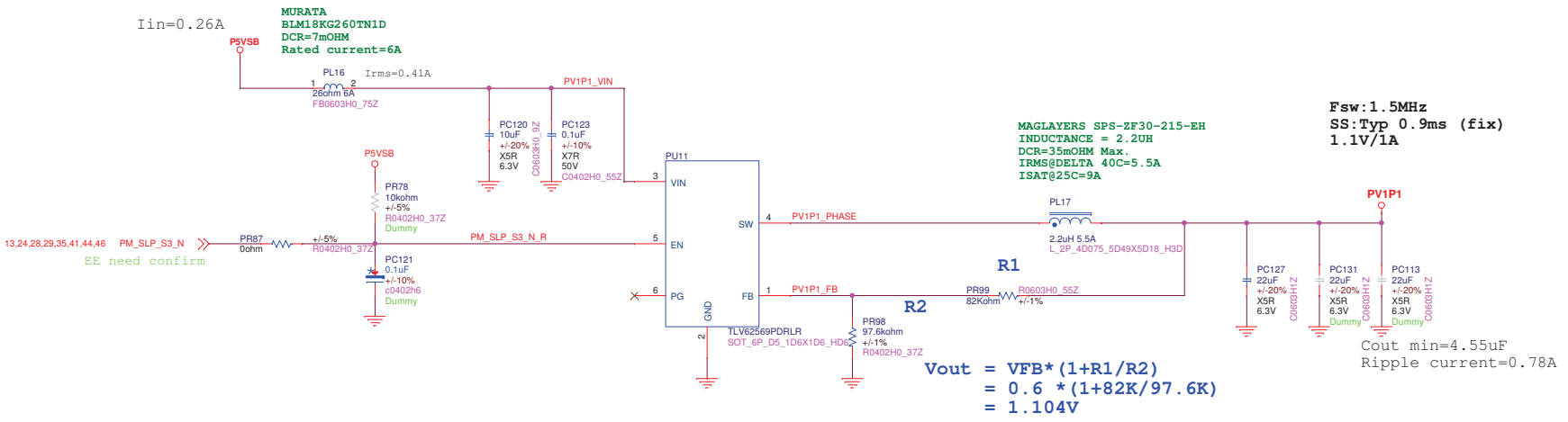
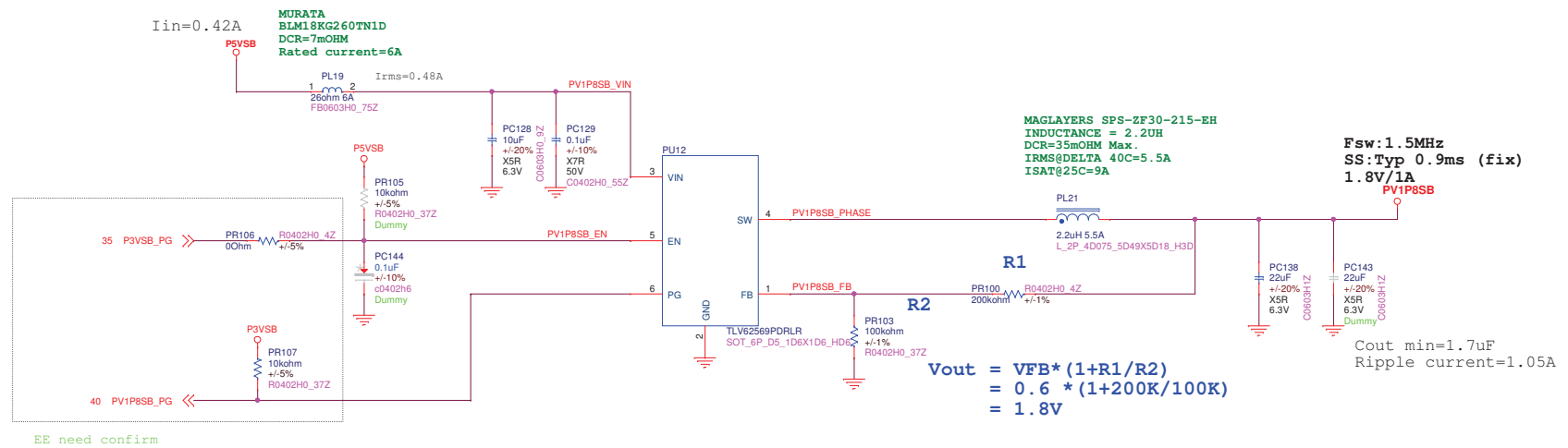

FOXCONN Foxconn Technology Group Ennoconn Corporation		Ennoconn Corporation Hardware R&D Dept.	
Title: PV1P8/PV1P5/PV1P1			
Size	Document Number	IPS_70CB	Rev 0.2
Date:	Friday, May 03, 2019	Sheet	43 of 57

Power rail :P12V
 Controller : LM5176PWPR
 VIN : 19~10.8V
 VOUT : 12V
 Fswitch = 347KHz

Boost
 VIN : 10.8V
 VOUT : 12V @2.5A

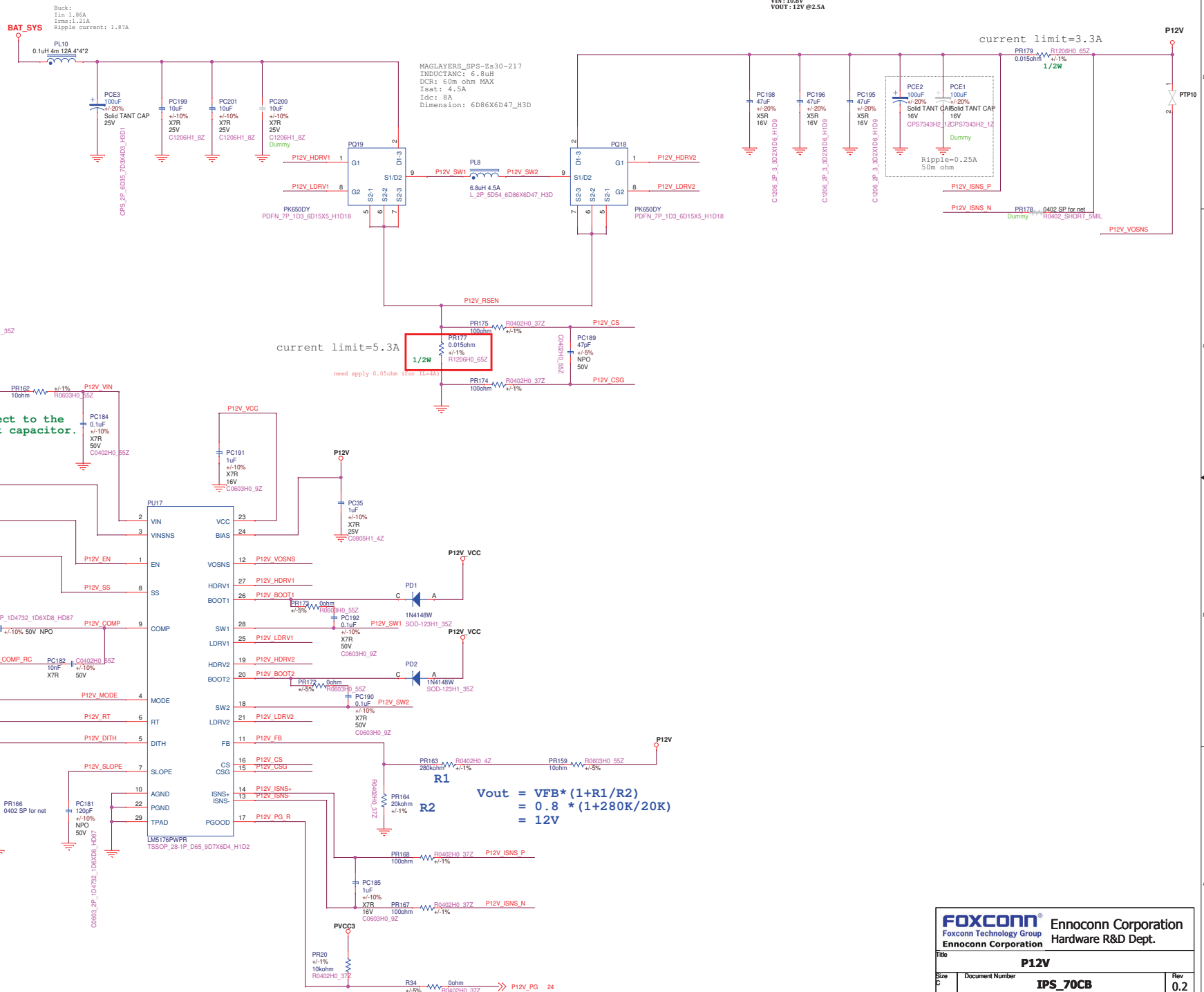

Connect to the input capacitor.

$$V_{out} = V_{FB} * (1 + R1/R2) = 0.8 * (1 + 280K/20K) = 12V$$

FOXCONN Ennoconn Corporation	
Foxconn Technology Group Hardware R&D Dept.	
Title: P12V	
Size: Document Number	Rev: 0.2
Date: Friday, May 03, 2019 Sheet 44 of 57	

5

4

3

2

1

D

D

C

C

B

B

A

A

 FOXCONN Foxconn Technology Group Ennoconn Corporation		Ennoconn Corporation Hardware R&D Dept.	
BLANK			
Size C	Document Number IPS_70CB	Rev 0.2	
Date: Friday, May 03, 2019		Sheet 45 of 57	

5

4

3

2

1

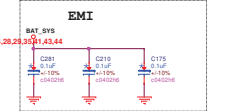
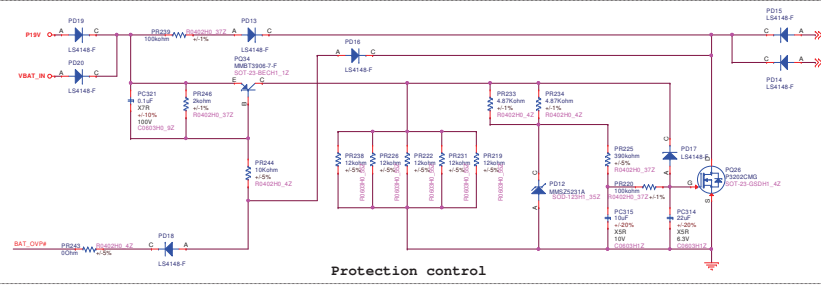
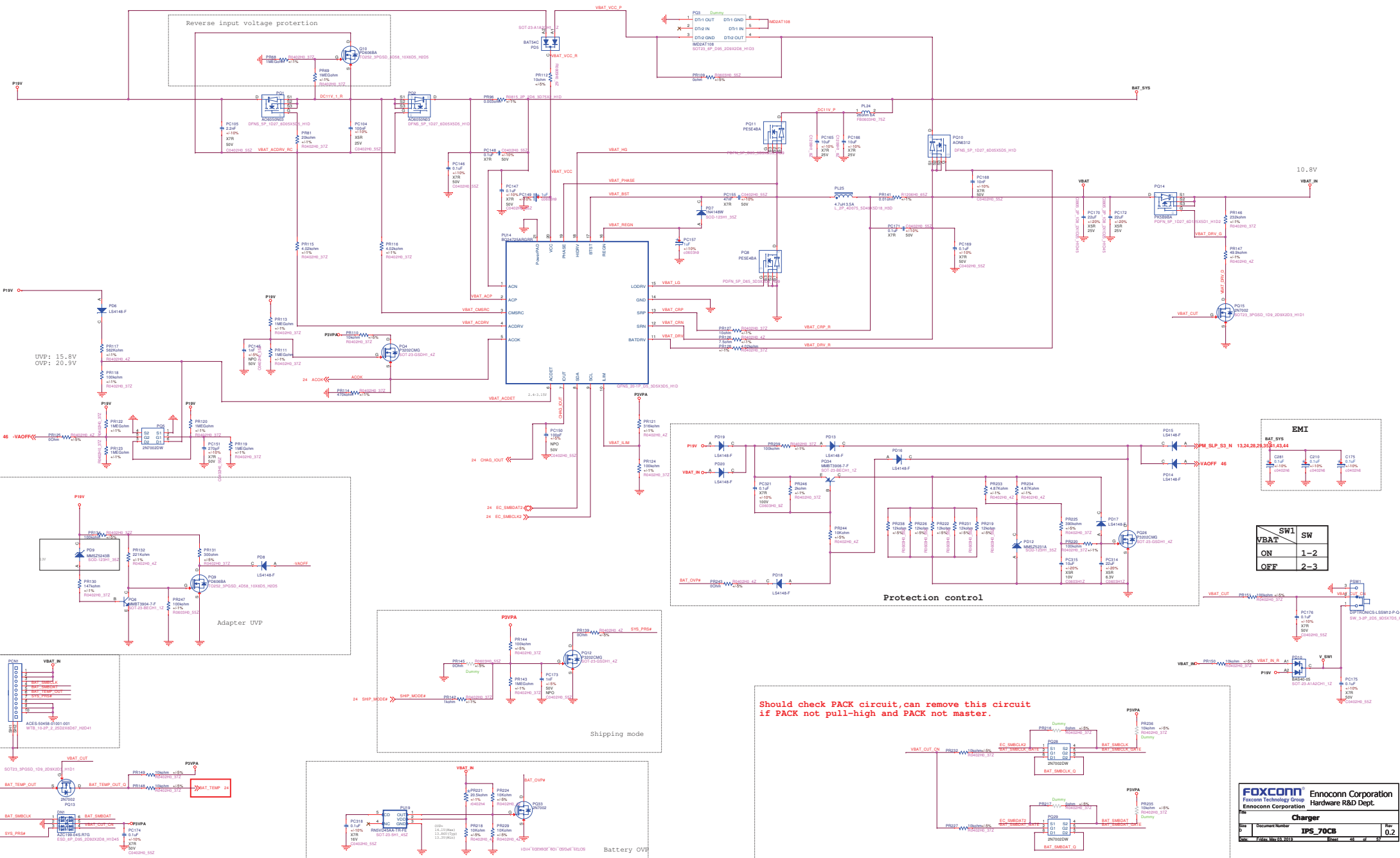

SW1	SW
ON	1-2
OFF	2-3

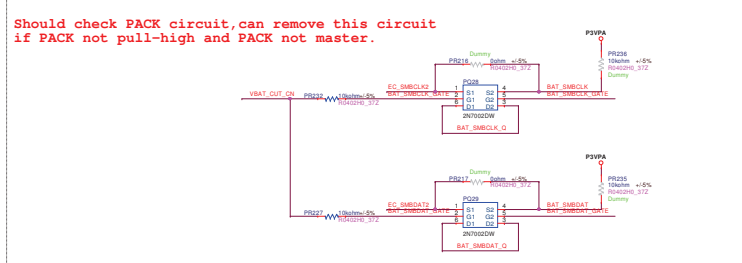

FOXCONN Ennoconn Technology Group
Ennoconn Corporation Hardware R&D Dept.
Charger

Doc No	Doc Number	Rev
0	IPS_70CB	0.2

Date: Friday, May 03, 2019 Sheet: 44 of 97

