

Modified schematic

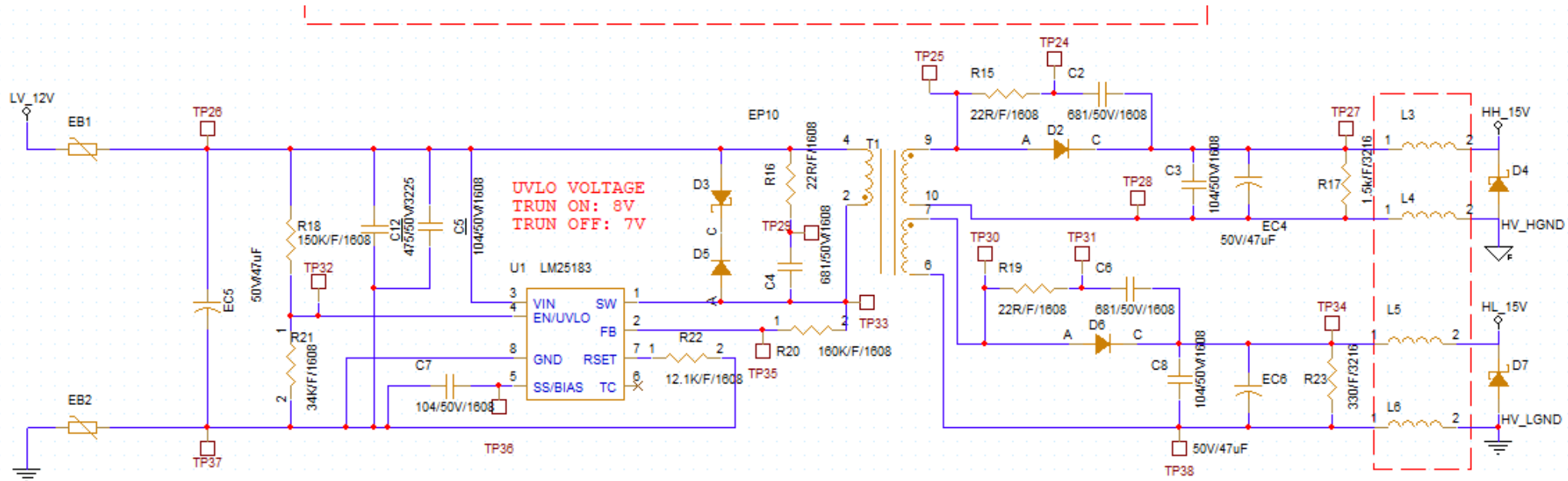

Modified design tool

Step 1: Operating Specifications LM25183

Input Voltage - Min, $V_{IN(min)}$	8 V
Input Voltage - Nom, $V_{IN(nom)}$	13 V
Input Voltage - Max, $V_{IN(max)}$	18 V
Single Output or Dual Outputs	DUAL
Output Voltage, V_{OUT1}	16 V
Rated Output Current, I_{OUT1}	0.15 A
Output Voltage, V_{OUT2}	16 V
Rated Output Current, I_{OUT2}	0.2 A

Step 2: Flyback Transformer

Minimum Magnetizing Inductance	12.7 μ H
Magnetizing Inductance, L_{MAG}	73 μ H
Primary Winding DCR	278 m Ω
Secondary Winding #1 DCR	356 m Ω
Secondary Winding #2 DCR	392 m Ω
Pri-Sec Leakage Inductance	100 nH
Turns Ratio, PRI : SEC1	1 : 1
Turns Ratio, SEC2 : SEC1	1
Max Output Power at $V_{IN(min)}$	6.11 W
Duty Cycle at $V_{IN(min)}$	67.9 %

Step 3: Input & Output Capacitors

Minimum Input Capacitance	2.2 μ F
Input Capacitance, C_{IN}	47 μ F
Input Capacitor ESR	900 m Ω
Resulting Input Voltage Ripple	505 mV _{pk-pk}
Minimum Output Capacitance, Output #1	5 μ F
Output Capacitance, C_{OUT}	47 μ F
Output Capacitor ESR	900 m Ω
Resulting Output Voltage Ripple, Output #1	149 mV _{pk-pk}

Minimum Output Capacitance, Output #2	7.4 μ F
Output Capacitance, C_{OUT2}	47 μ F
Output Capacitor ESR	900 m Ω
Resulting Output Voltage Ripple, Output #2	205 mV _{pk-pk}

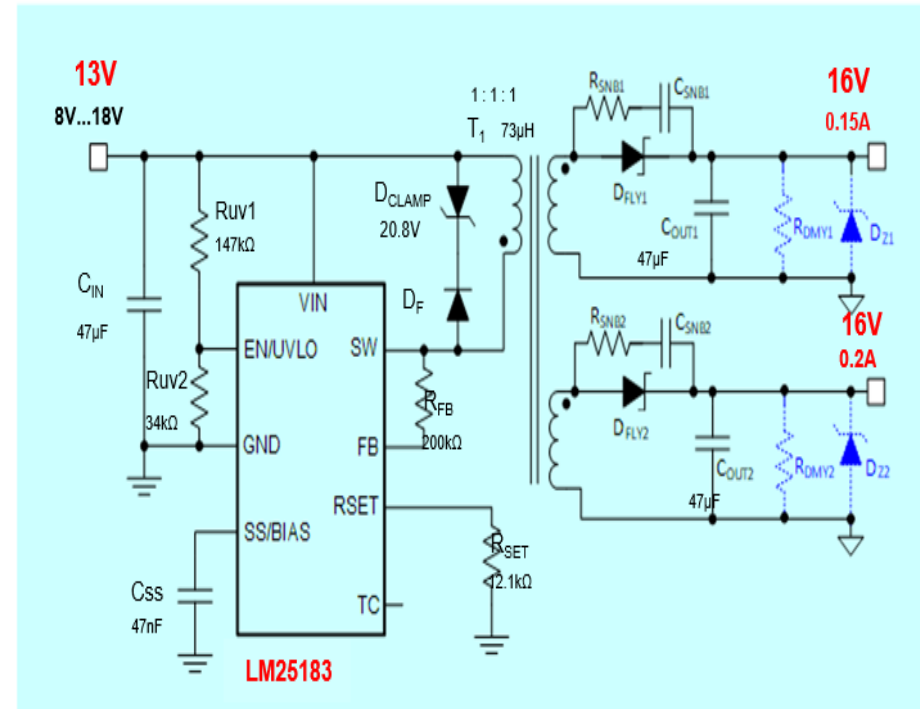

Step 4: Feedback, Soft-start, TC, UVLO

Recommended Feedback Resistor	169.0 k Ω
Selected Feedback Resistor, R_{FB}	200 k Ω
Soft-Start Configuration	Adjustable

