

### 5V POWER

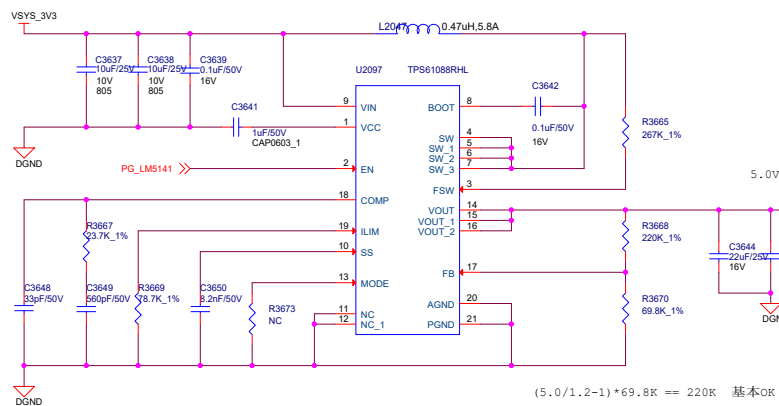

### VDD\_IO\_1V8\_B

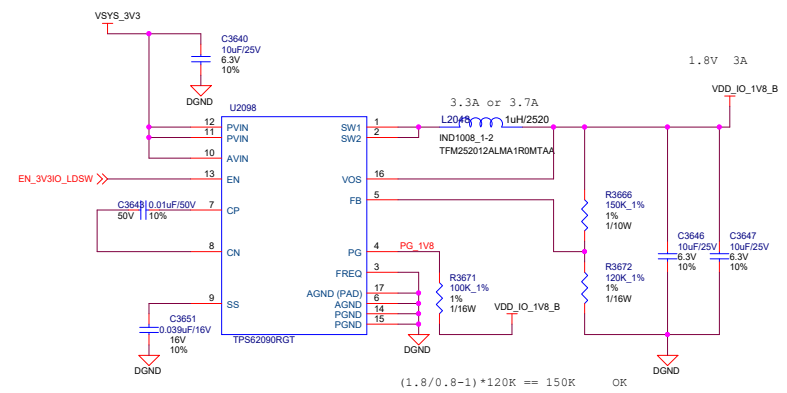

### VDD\_IO\_1V1

