

# 12V BUCK BOOST REGULATOR

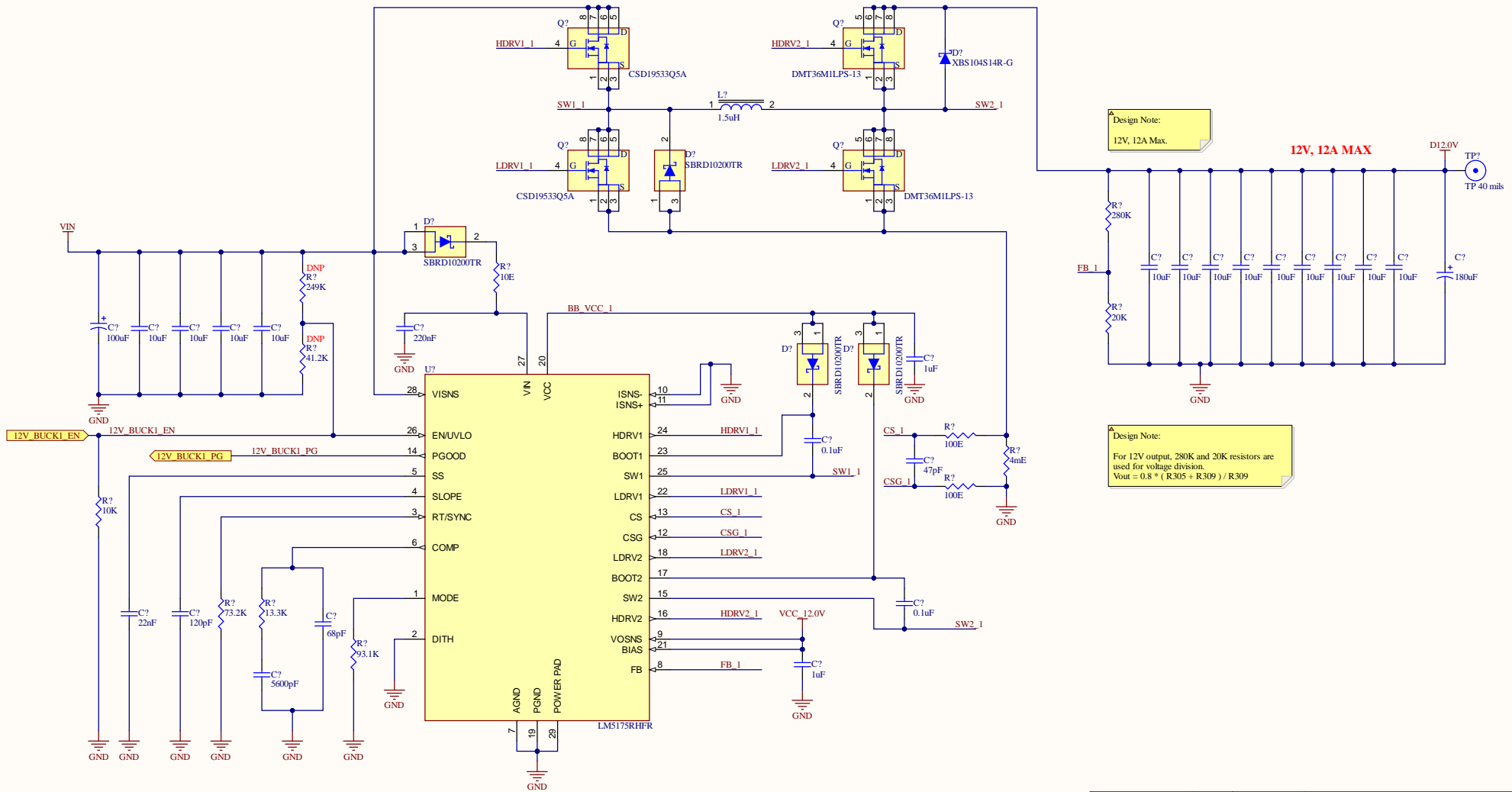

| APPROVALS | DATE | PROJECT             | Altium                                    |                                     |
|-----------|------|---------------------|---|-------------------------------------|
| ENG: -    |      | PROJECT REVISION: - | DOCUMENT REVISION: Not in version control | DESIGN ITEM: Not in version control |
| DSN: -    |      | TITLE: *            |   |                                     |
| CHK: -    |      | REFERENCE DOCUMENTS |   |                                     |
| BOM:      |      | SIZE: A3            | CAGE CODE:                                | DWG NO.:                            |
| ASSY DWG: |      | SCALE:              | FILE NAME: LM5175RHFR.SchDoc              | SHEET 1 OF 1                        |
| FAB DWG:  |      |                     |   |                                     |
| PCB DWG:  |      |                     |   |                                     |

| Comment                 | Description   | Designator | Footprint             | LibRef  | Quantity |
|-------------------------|---|------------|-----------------------|---|----------|
| CAP NON POL             | CAP,CER,1uF,25V,10%<br>X5R,0402,SMD,<br>CAP,CER,47pF,50V,5%<br>COG/NP0,0402,SMD,<br>CAP,CER,0.1uF,50V, +/-20%, X5R,0402,SMD,<br>CAP,CER,120PF,50V,10%<br>COG/NP0,0402,SMD,<br>CAP,CER,68pF,50V,1%<br>COG/NP0,0402,SMD,<br>CAP,CER,22nF,50V,5%<br>X7R,0402,SMD | C?         | CAPC1005X50N          | GAD100074,<br>GAD100204,<br>GAD100388,<br>GAD100067,<br>GAD100030,<br>GAD100150 | 7        |
| CAP NON POL             | CAP,CER,1uF,16V,10%<br>X7R,0603,SMD   | C?         | CAPC1508X55N          | GAD100678   | 1        |
| CAP NON POL             | CAP,CER,10uF,50V,10%<br>X5R,0805,SMD,<br>CAP,CER,5600pF,50V,5%<br>COG,0805,SMD,<br>CAP,CER,220nF,100V,10%<br>X7R,0805   | C?         | CAPC2012X85N          | GAD100589,<br>GAD100584,<br>GAD100481   | 11       |
| CAP NON POL             | CAP,CER,10uF,100V,20%<br>X7S,1210,SMD   | C?         | CAPC3126X270N         | GAD100622   | 4        |
| CAP POL                 | CAP,ALUM,180uF,25V,20%<br>SMD   | C?         | CAPAE660X770N         | GAD100364   | 1        |
| CAP POL                 | CAP,ALUM,100uF,50V,20%<br>6.3x7.7mm,SMD   | C?         | CAPAE680X800N         | GAD100520   | 1        |
| DIODE_SCH               | DIODE,SCHOTTKY,40V,1A,<br>SOD123A   | D?         | SOD385170X125N        | GAD430233   | 1        |
| DIODE_SCH_3P_B          | DIODE,SCHOTTKY,200V,10A,<br>DPAK  | D?         | TO228P1040X240-4_3N   | GAD430078   | 4        |
| FIXEDINDUCTOR IRON CORE | IND,UNSHIELDED,MOLEDED,<br>1.5uH,27A,3mOHM,20%<br>SMD   | L?         | INDM128X128X65N       | GAD200349   | 1        |
| CSD19533Q5A             | MOSFET,N-CH,100V,100A,8-VSON  | Q?         | SON127P500X580X110-8N | GAD400171   | 2        |
| DMT36M1LPS-13           | MOSFET,N-CH,30V,65A,8-PowerTDFN   | Q?         | DFN600X510X110-8N     | GAD400170   | 2        |
| 4mE                     | RES,4mE,3W,1%,2512,SMD  | R?         | RESC6634X90N          | GAD001109   | 1        |
| 10E                     | RES,10E,1/10W,5%,0603,SMD   | R?         | RESC1508X55N          | GAD000370   | 1        |
| 10K                     | RES,10K,1/16W,1%,0402,SMD   | R?         | RESC1005X50N          | GAD000004   | 1        |
| 13.3K                   | RES,13.3K,0.1%,1/16W,0402,SMD   | R?         | RESC1005X50N          | GAD000234   | 1        |
| 20K                     | RES,20K,1/16W,1%,0402,SMD   | R?         | RESC1005X50N          | GAD000158   | 1        |
| 41.2K                   | RES,41.2K,1/16W,1%,0402,SMD   | R?         | RESC1005X50N          | GAD000879   | 1        |
| 73.2K                   | RES,73.2K,1/16W,1%,0402,SMD   | R?         | RESC1005X50N          | GAD000505   | 1        |
| 93.1K                   | RES,93.1K,1/10W,1%,0603,SMD   | R?         | RESC1508X55N          | GAD001108   | 1        |
| 100E                    | RES,100E,1/16W,1%,0402,SMD  | R?         | RESC1005X50N          | GAD000001   | 2        |
| 249K                    | RES,249K,1/16W,1%,0402,SMD  | R?         | RESC1005X50N          | GAD000348   | 1        |
| 280K                    | RES,280K,OHM,1%,1/16W,0402,SMD  | R?         | RESC1005X50N          | GAD000155   | 1        |
| LMS175RHFR              | IC,BUCK-BOOST,3.5V-42VIN,0.8-55VOUT,1CH,28-VQFN   | U?         | QFN50P410X510X100-29N | GAD460416   | 1        |