

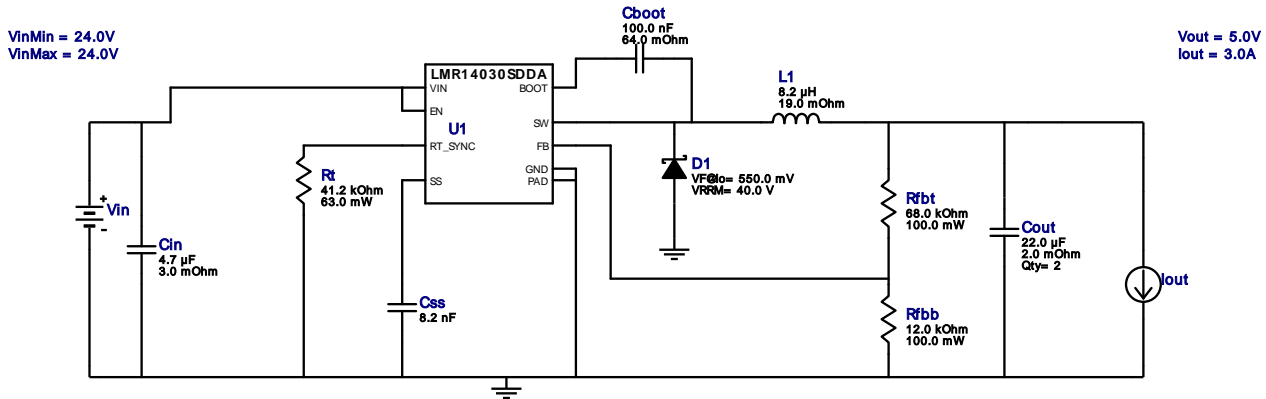

WEBENCH® Design Report

 Design : 1186583/7287 LMR14030SDDAR
 LMR14030SDDAR 24.0V-24.0V to 5.00V @ 3.0000625A

Electrical BOM

#	Name	Manufacturer	Part Number	Properties	Qty	Price	Footprint
1.	Cboot	Kemet	C0805C104K5RACTU Series= X7R	Cap= 100.0 nF ESR= 64.0 mOhm VDC= 50.0 V IRMS= 1.64 A	1	\$0.01	 0805 7 mm ²
2.	Cin	MuRata	GRM31CR71H475KA12L Series= X7R	Cap= 4.7 uF ESR= 3.0 mOhm VDC= 50.0 V IRMS= 4.98 A	1	\$0.07	 1206 11 mm ²
3.	Cout	MuRata	GRM32ER61C226KE20L Series= X5R	Cap= 22.0 uF ESR= 2.0 mOhm VDC= 16.0 V IRMS= 3.68 A	2	\$0.16	 1210 15 mm ²
4.	Css	MuRata	GRM155R71C822KA01D Series= X7R	Cap= 8.2 nF VDC= 16.0 V IRMS= 0.0 A	1	\$0.01	 0402 3 mm ²
5.	D1	Diodes Inc.	B540C-13-F	VF@Io= 550.0 mV VRRM= 40.0 V	1	\$0.17	 SMC 83 mm ²
6.	L1	Bourns	SDR1307-8R2ML	L= 8.2 µH DCR= 19.0 mOhm	1	\$0.35	 SDR1307 227 mm ²
7.	Rfbb	Susumu Co Ltd	RR1220P-123-D Series= RR12	Res= 12.0 kOhm Power= 100.0 mW Tolerance= 0.5%	1	\$0.01	 0805 7 mm ²
8.	Rfbt	Susumu Co Ltd	RR1220P-683-D Series= RR12	Res= 68.0 kOhm Power= 100.0 mW Tolerance= 0.5%	1	\$0.01	 0805 7 mm ²
9.	Rt	Vishay-Dale	CRCW040241K2FKED Series= CRCW..e3	Res= 41.2 kOhm Power= 63.0 mW Tolerance= 1.0%	1	\$0.01	 0402 3 mm ²

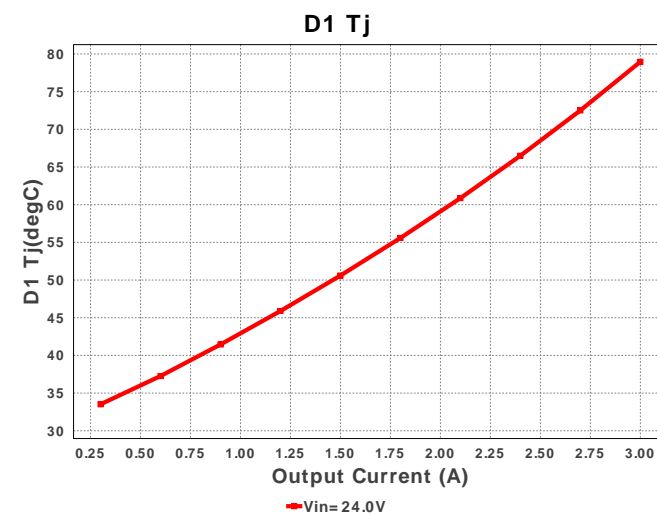
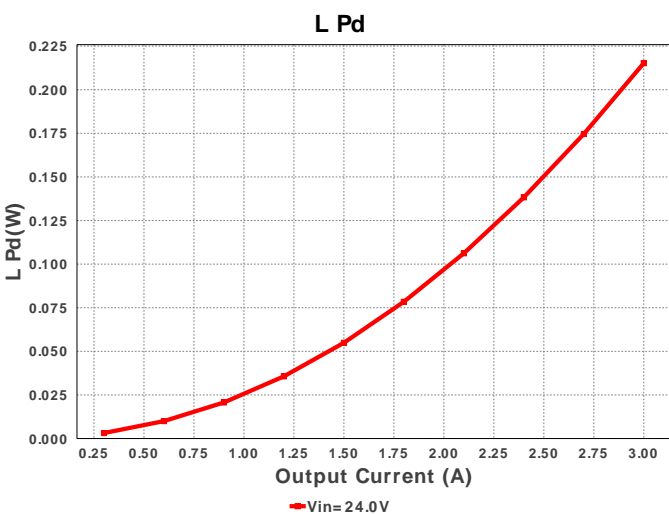
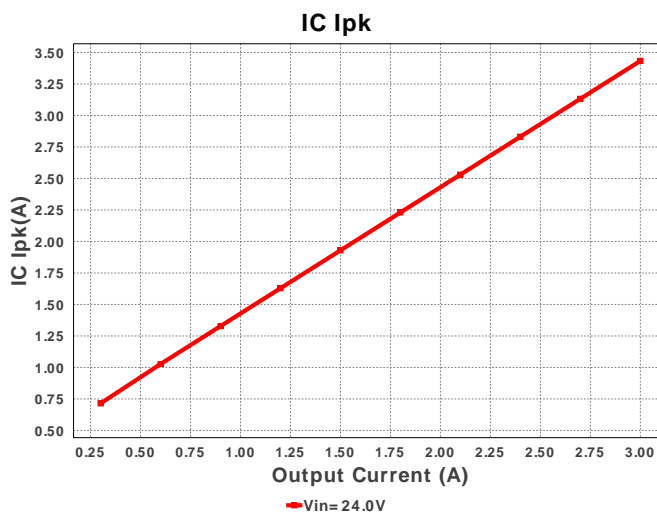
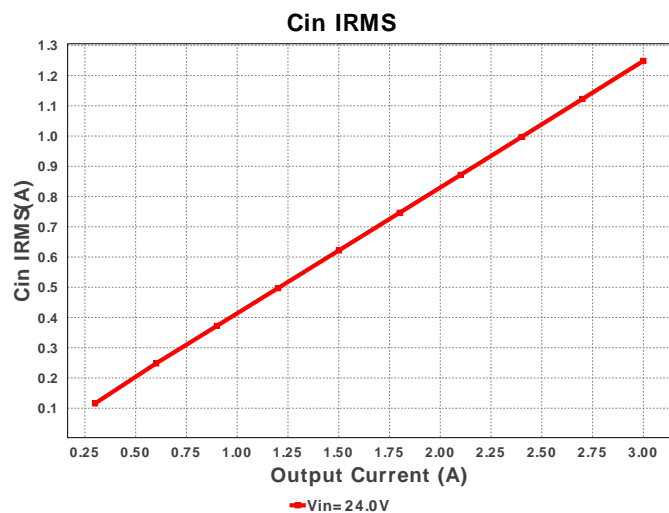
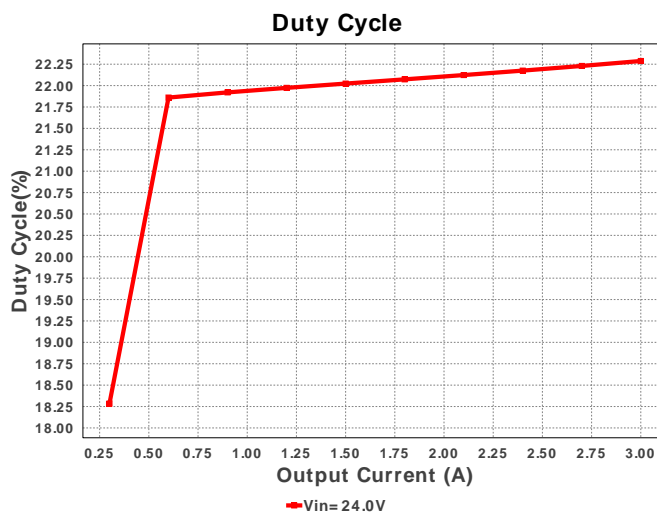
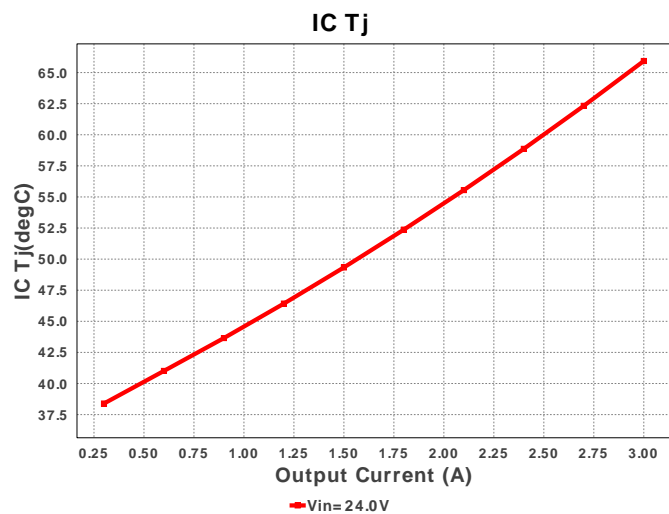
#	Name	Manufacturer	Part Number	Properties	Qty	Price	Footprint
10.	U1	Texas Instruments	LMR14030SDDAR	Switcher	1	\$1.68	 DDA0008E 57 mm ²

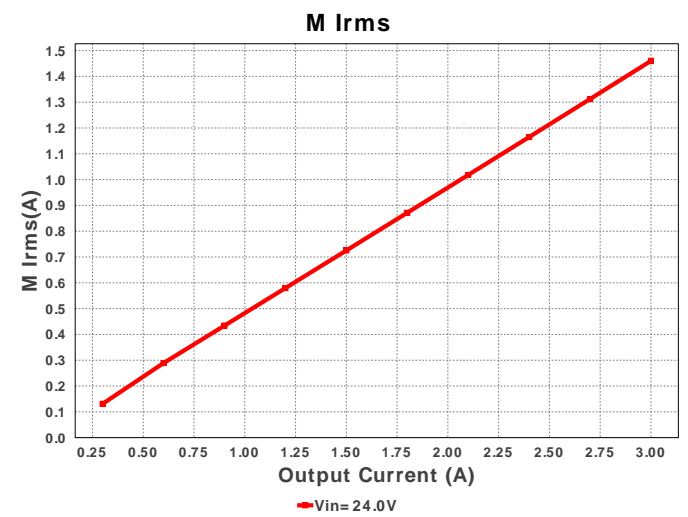
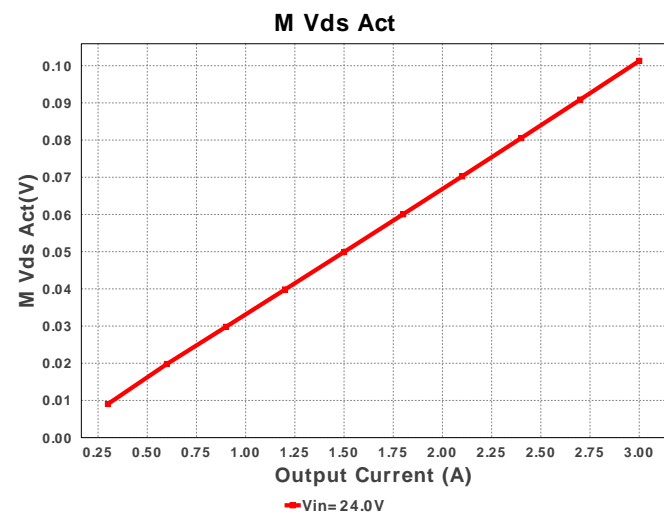
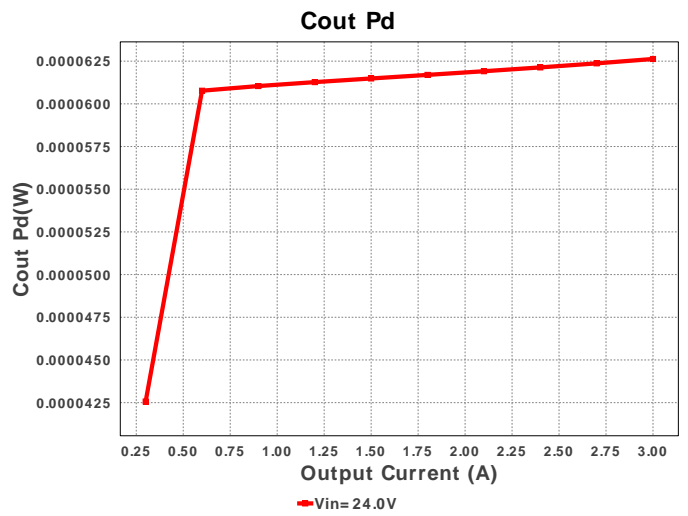
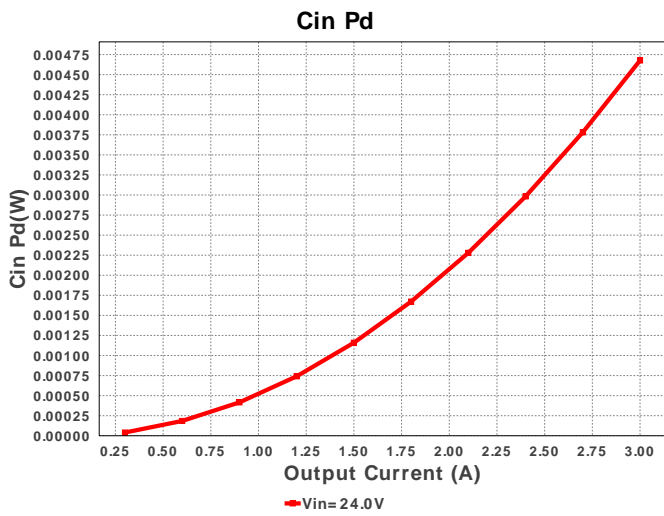
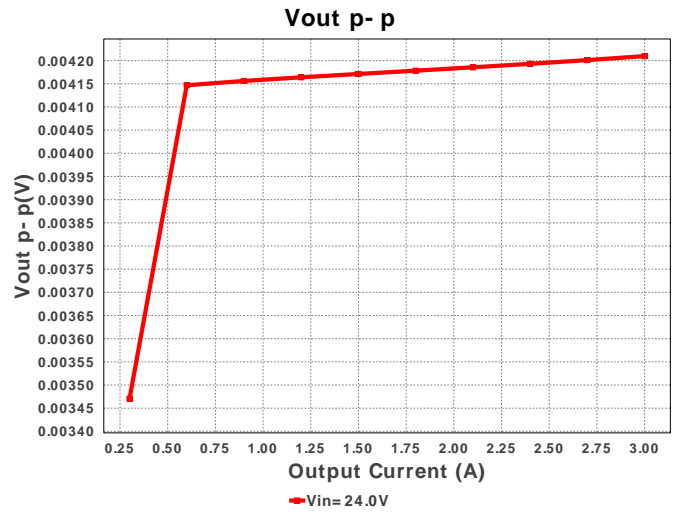
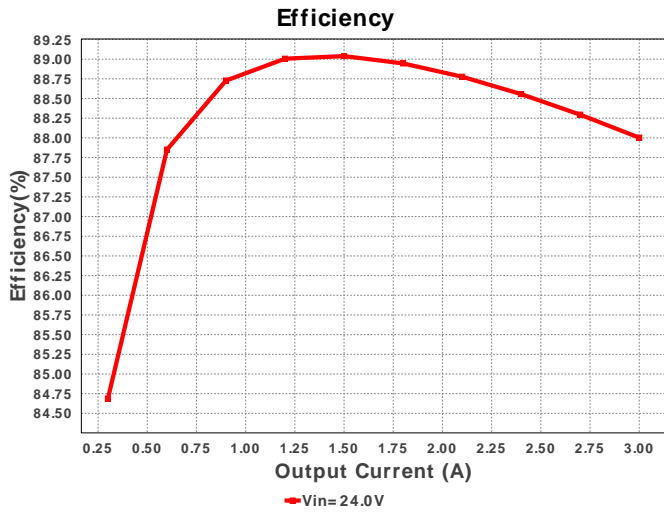

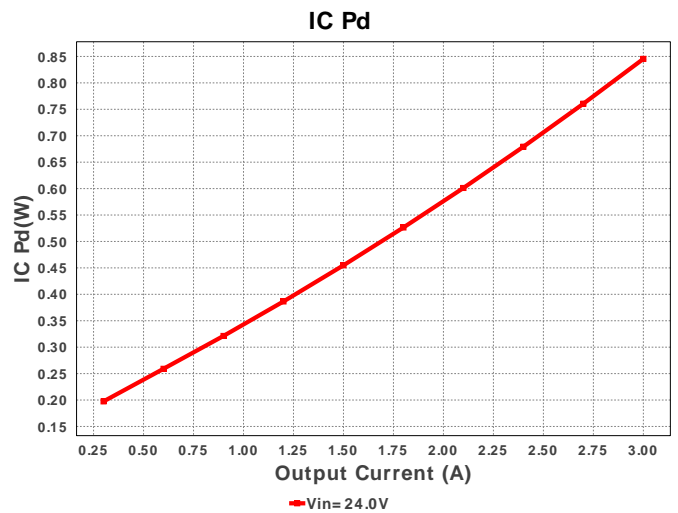
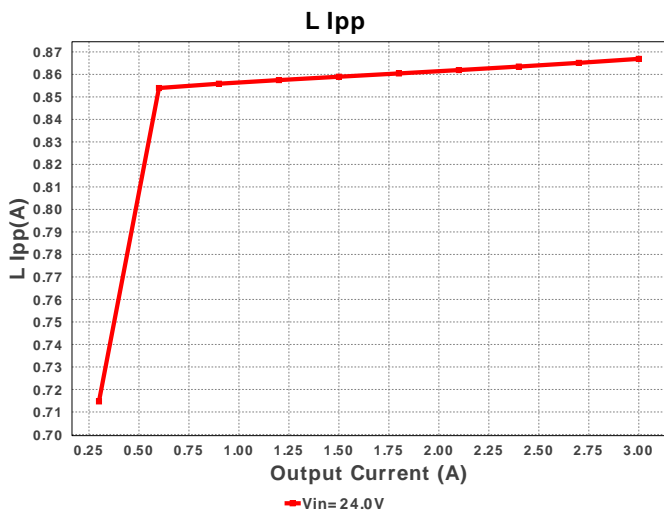
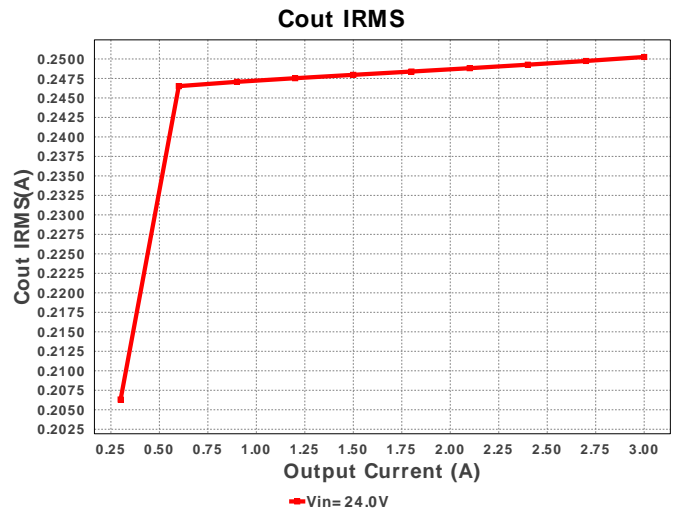
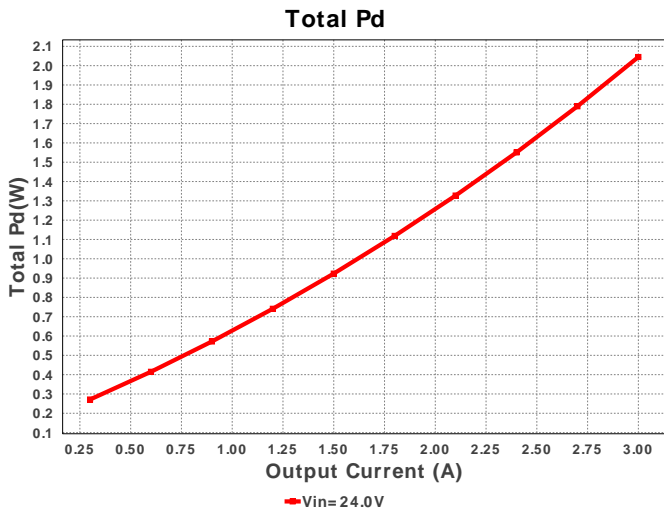
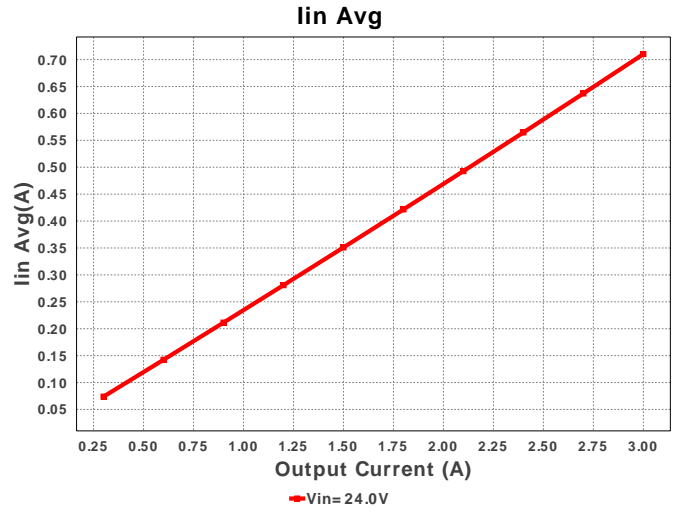
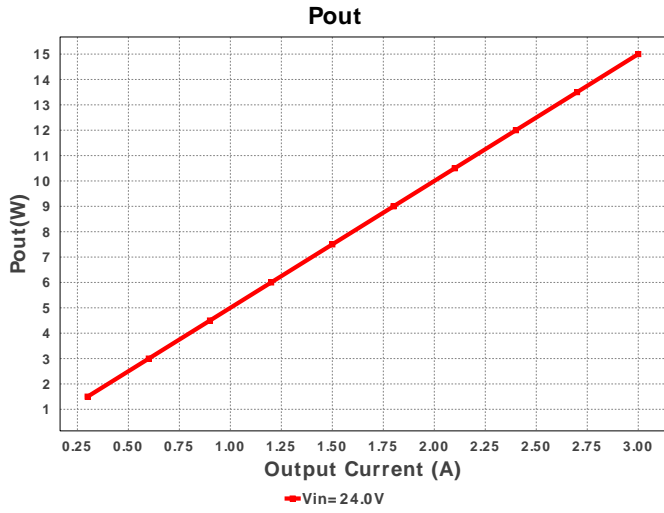



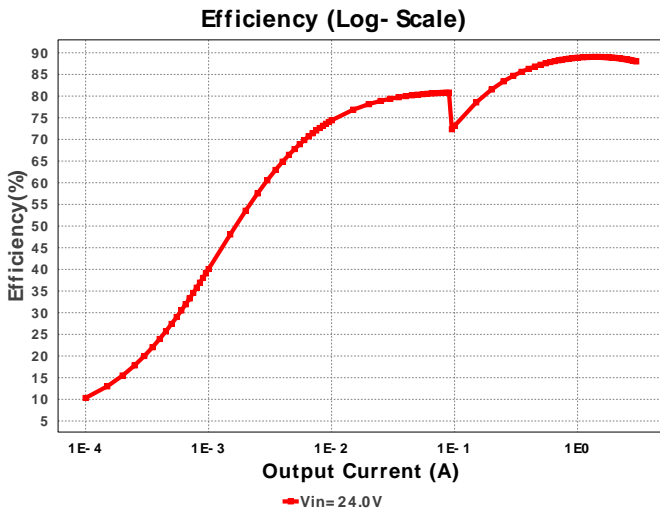
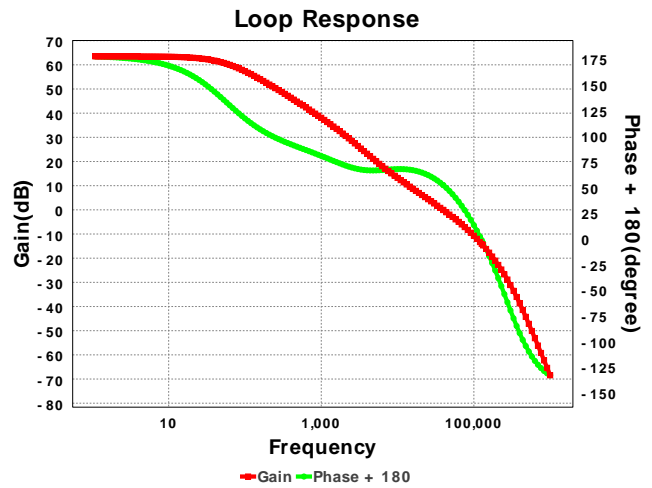
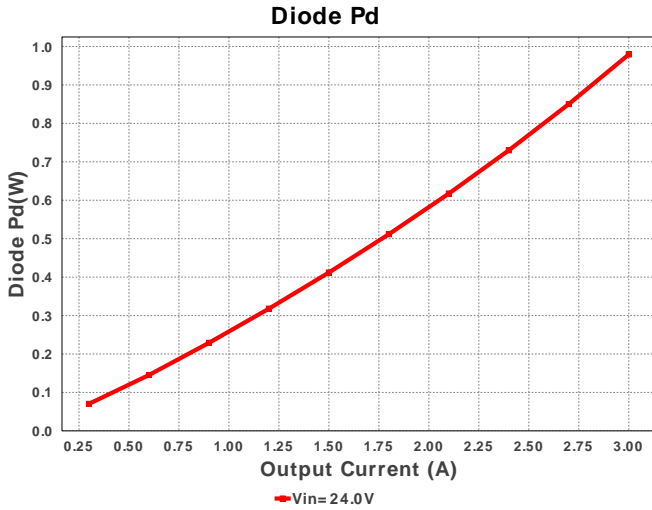

Operating Values

#	Name	Value	Category	Description
1.	Cin IRMS	1.249 A	Current	Input capacitor RMS ripple current
2.	Cout IRMS	250.254 mA	Current	Output capacitor RMS ripple current
3.	IC Ipk	3.434 A	Current	Peak switch current in IC
4.	Iin Avg	710.22 mA	Current	Average input current
5.	L Ipp	866.9 mA	Current	Peak-to-peak inductor ripple current
6.	M1 Irms	1.46 A	Current	Q lavg
7.	BOM Count	11	General	Total Design BOM count
8.	FootPrint	434.0 mm ²	General	Total Foot Print Area of BOM components
9.	Frequency	592.527 kHz	General	Switching frequency
10.	IC Tolerance	18.0 mV	General	IC Feedback Tolerance
11.	M Vds Act	101.265 mV	General	Voltage drop across the MosFET
12.	Pout	15.0 W	General	Total output power
13.	Total BOM	\$2.64	General	Total BOM Cost
14.	D1 Tj	78.964 degC	Op_Point	D1 junction temperature
15.	Vout OP	5.0 V	Op_Point	Operational Output Voltage
16.	Cross Freq	39.498 kHz	Op_point	Bode plot crossover frequency
17.	Duty Cycle	22.287 %	Op_point	Duty cycle
18.	Efficiency	88.003 %	Op_point	Steady state efficiency
19.	IC Tj	65.506 degC	Op_point	IC junction temperature
20.	ICThetaJA	42.0 degC/W	Op_point	IC junction-to-ambient thermal resistance
21.	IOUT_OP	3.0 A	Op_point	Iout operating point
22.	Phase Marg	53.652 deg	Op_point	Bode Plot Phase Margin
23.	VIN_OP	24.0 V	Op_point	Vin operating point
24.	Vout p-p	4.21 mV	Op_point	Peak-to-peak output ripple voltage
25.	Cin Pd	4.677 mW	Power	Input capacitor power dissipation
26.	Cout Pd	62.627 μW	Power	Output capacitor power dissipation
27.	Diode Pd	979.285 mW	Power	Diode power dissipation
28.	IC Pd	845.388 mW	Power	IC power dissipation
29.	L Pd	215.246 mW	Power	Inductor power dissipation
30.	Total Pd	2.045 W	Power	Total Power Dissipation

Design Inputs

#	Name	Value	Description
1.	Iout	3.0	Maximum Output Current
2.	Iout1	3.0	Output Current #1
3.	VinMax	24.0	Maximum input voltage
4.	VinMin	24.0	Minimum input voltage
5.	Vout	5.0	Output Voltage
6.	Vout1	5.0	Output Voltage #1
7.	base_pn	LMR14030S	Base Product Number
8.	source	DC	Input Source Type
9.	Ta	30.0	Ambient temperature
10.	UserFsw	600.0 k	Customer Selected Frequency

Design Assistance

1. **LMR14030S** Product Folder : <http://www.ti.com/product/LMR14030> : contains the data sheet and other resources.

Texas Instruments' WEBENCH simulation tools attempt to recreate the performance of a substantially equivalent physical implementation of the design. Simulations are created using Texas Instruments' published specifications as well as the published specifications of other device manufacturers. While Texas Instruments does update this information periodically, this information may not be current at the time the simulation is built. Texas Instruments does not warrant the accuracy or completeness of the specifications or any information contained therein. Texas Instruments does not warrant that any designs or recommended parts will meet the specifications you entered, will be suitable for your application or fit for any particular purpose, or will operate as shown in the simulation in a physical implementation. Texas Instruments does not warrant that the designs are production worthy.

You should completely validate and test your design implementation to confirm the system functionality for your application prior to production.

Use of Texas Instruments' WEBENCH simulation tools is subject to [Texas Instruments' Site Terms and Conditions of Use](#). Prototype boards based on WEBENCH created designs are provided AS IS without warranty of any kind for evaluation and testing purposes and are subject to the terms of the [Evaluation License Agreement](#).