

Schematics of the main board

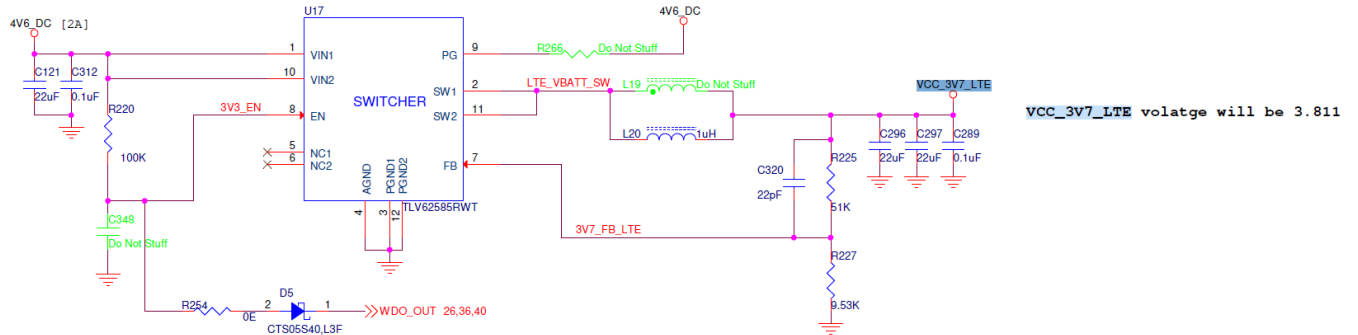

Please note that all the experiments mentioned in this doc were conducted by making C320(Feedforward capacitor) not mounted. In our design also we will make same change

Schematics of LTE board power

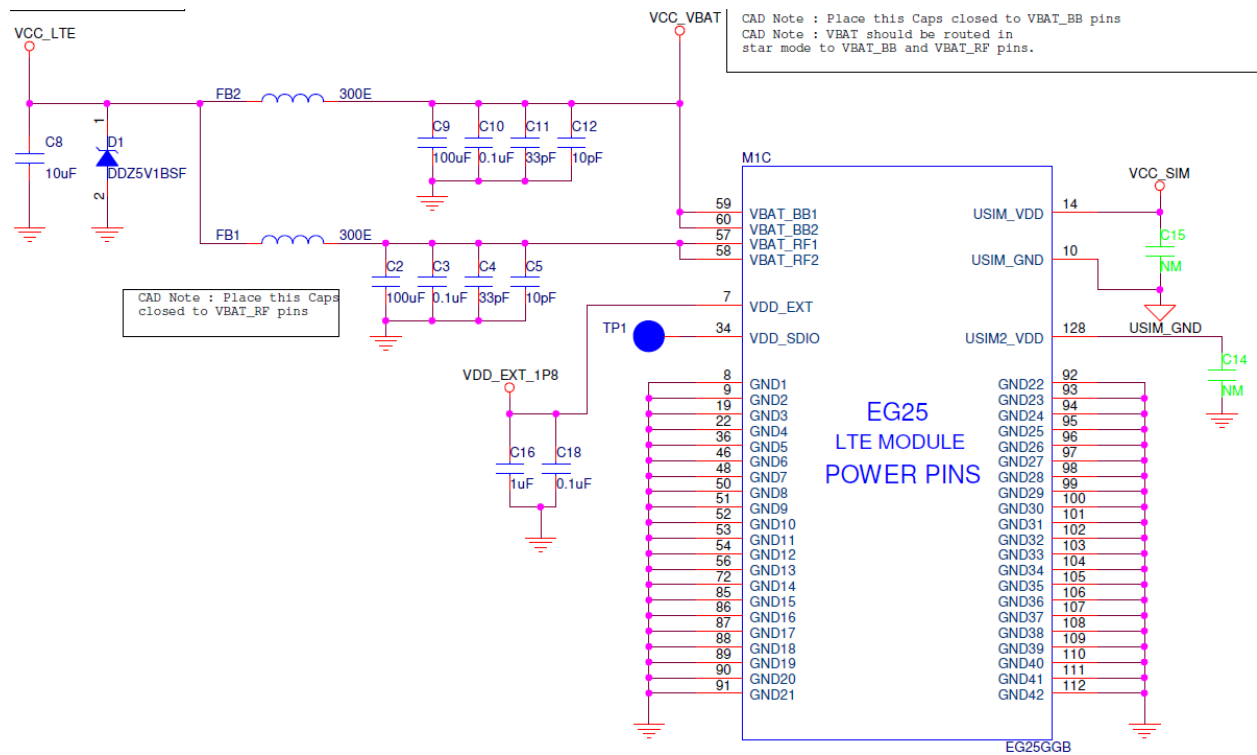

Above is our LTE module power section circuit. LTE is on different board. Both LTE and main brd connected using a B2B connector. We measured the ripple from VBAT_BB2 pin and VBAT_RF1 pins with respect to ground.

Below attaching the snap shot from the scope.

SW node of Buck:

With no load:

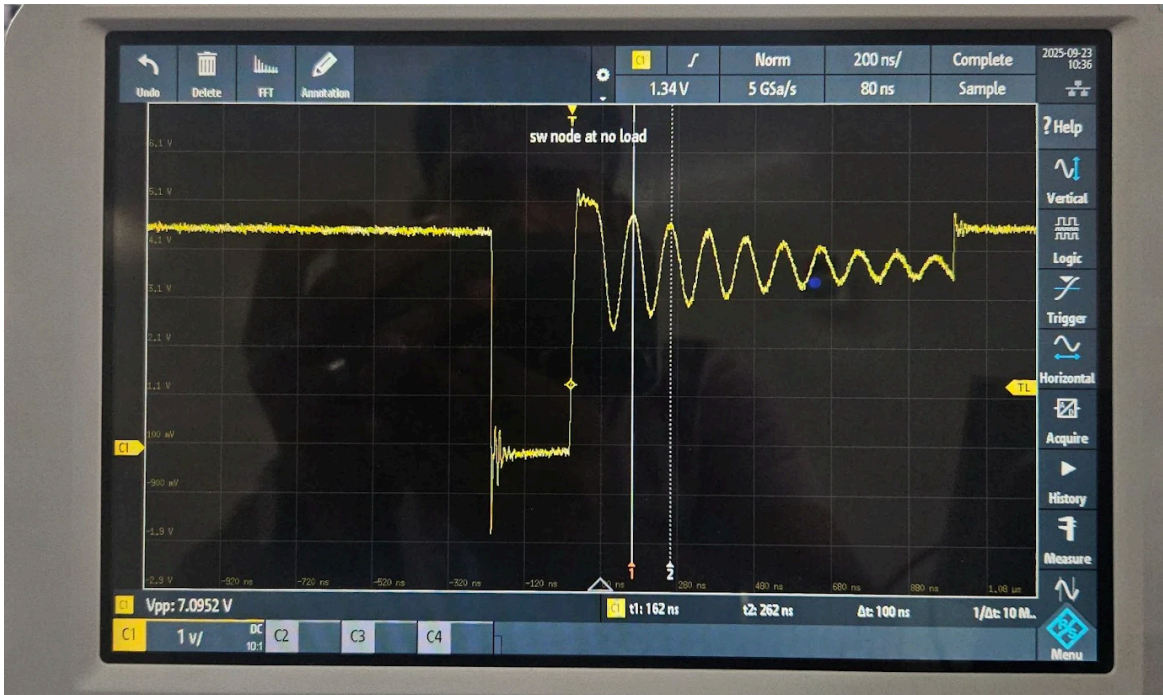

With Full load:

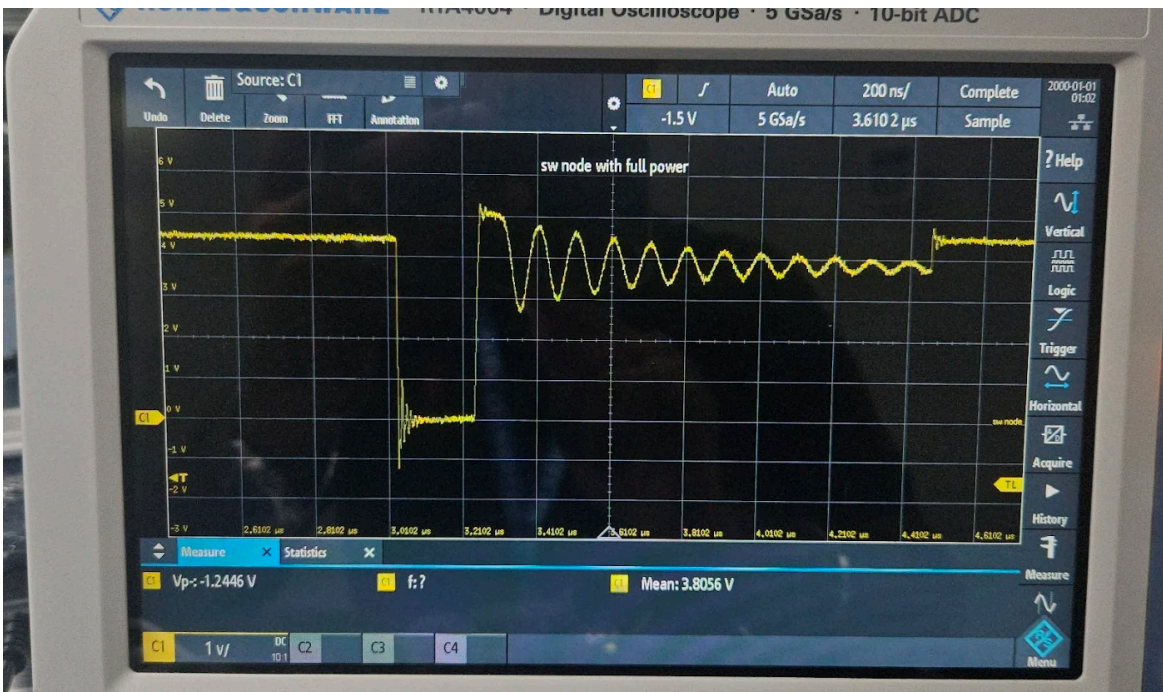



Ripple at Source side (Probed from Buck COUT caps)

At no load:

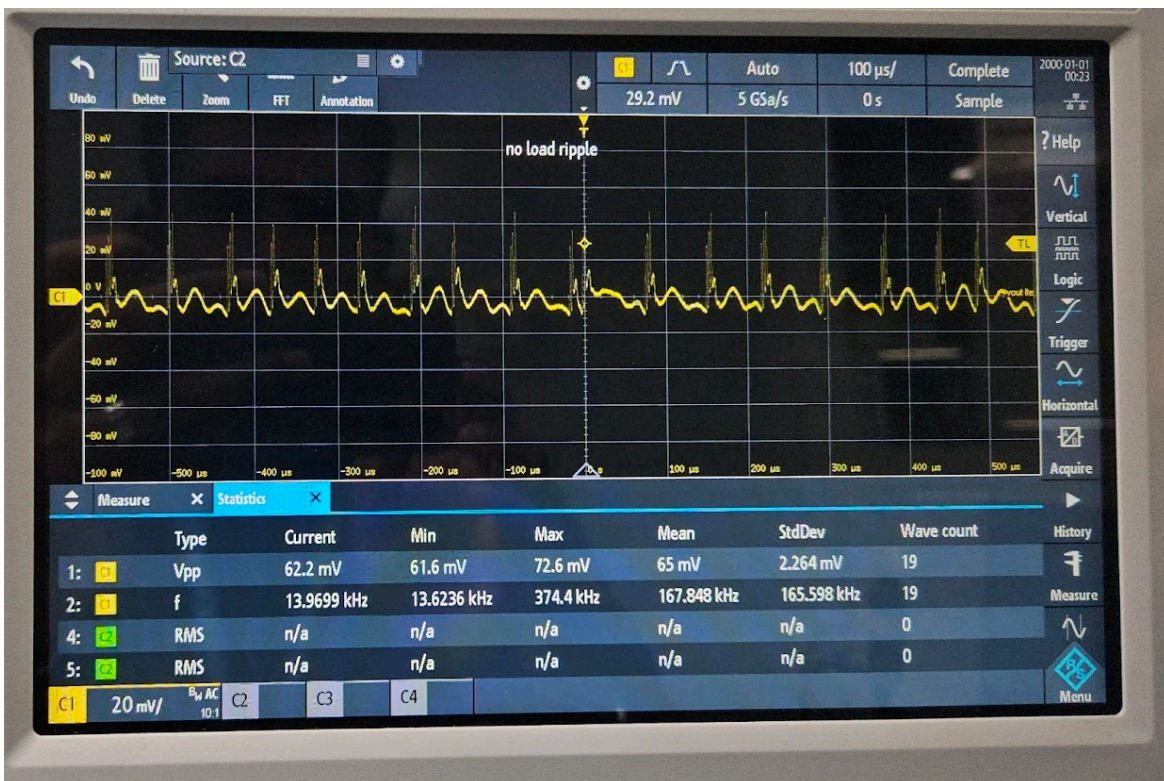

At full load:

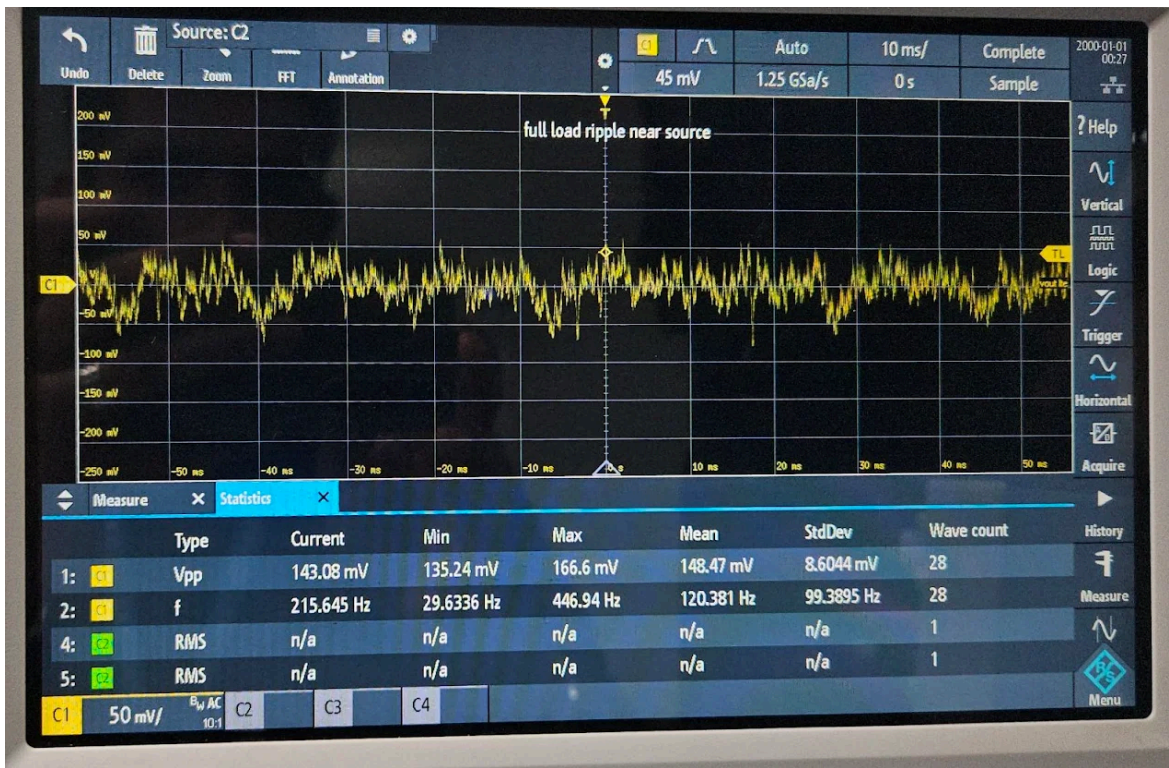

Ripple at Load side (Probed from LTE module input pins)

(Please refer the LTE brd circuit shown in previous pages. There is Ferrite bead FB2, FB1 on the path so it's effects need to consider on the ripple)

At rf pin side:

With no load

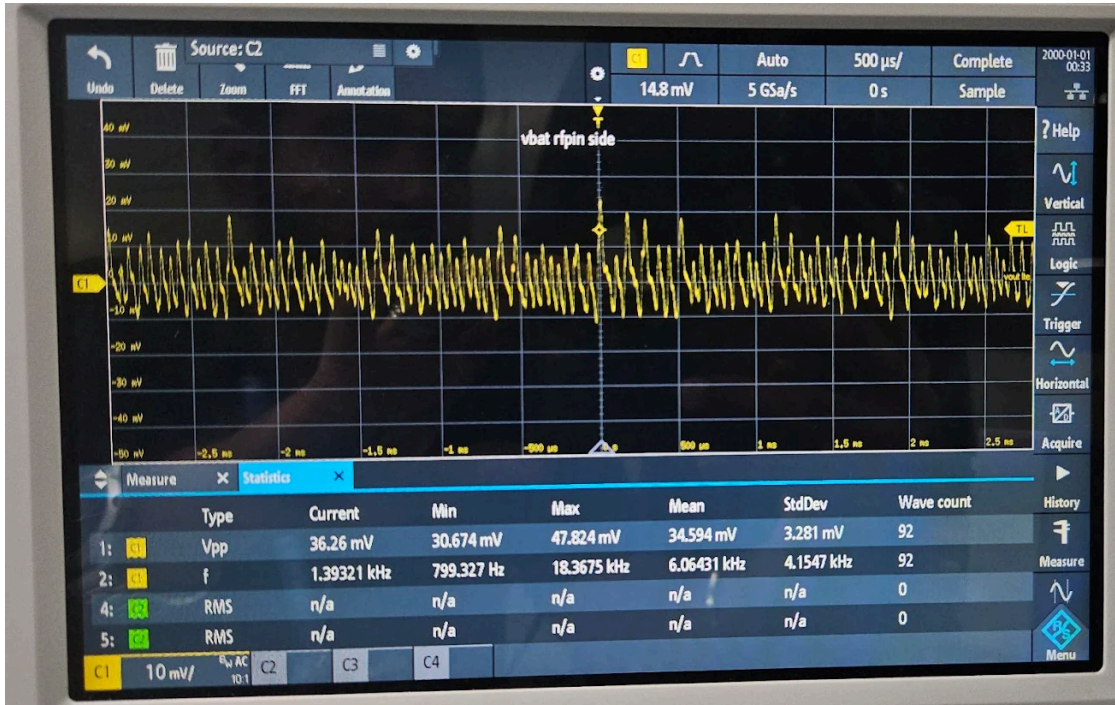

With full load:

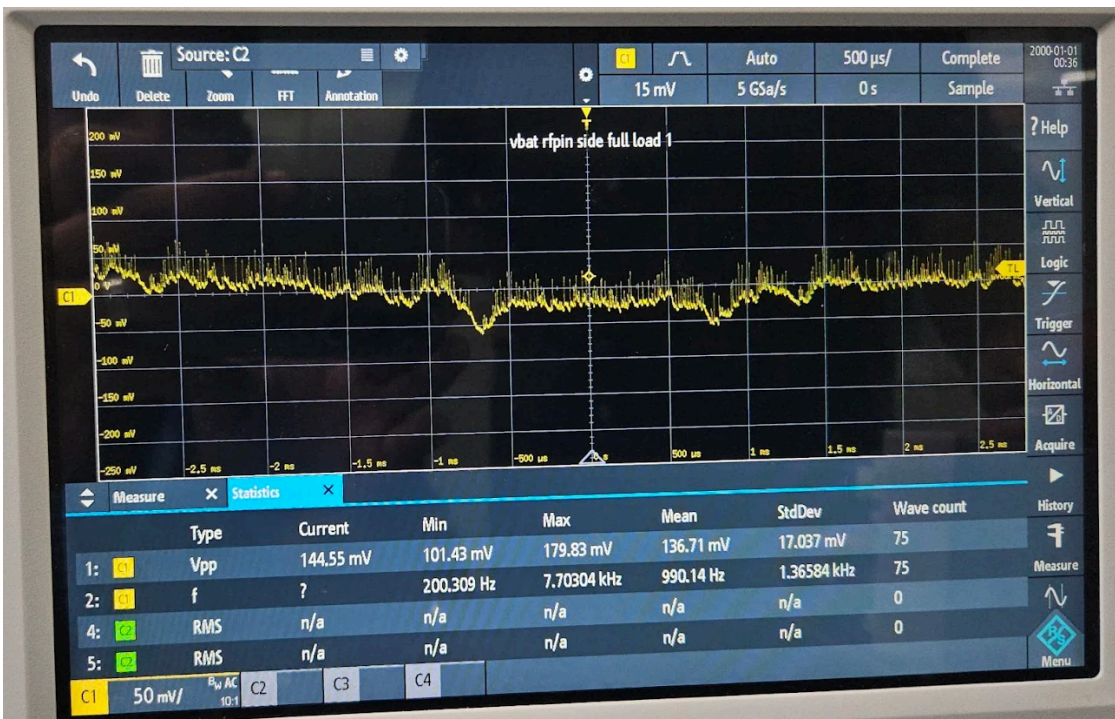

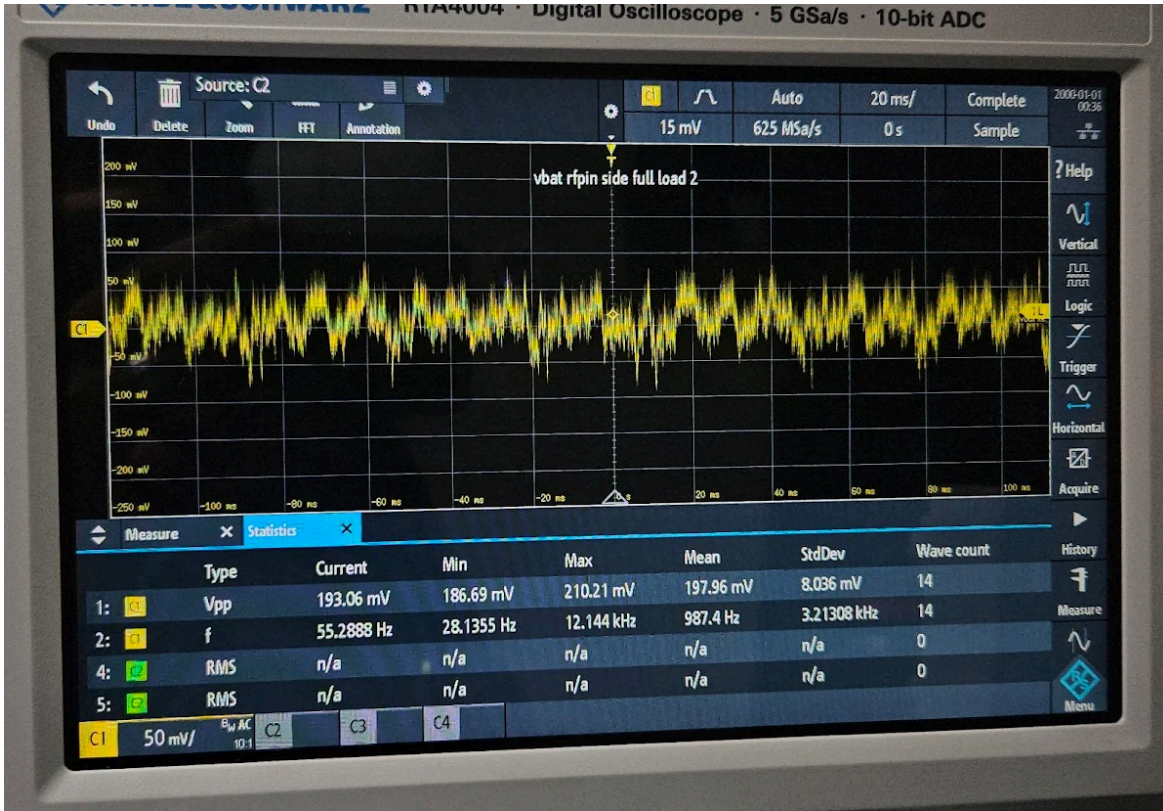

At BB pin side:
At no load:

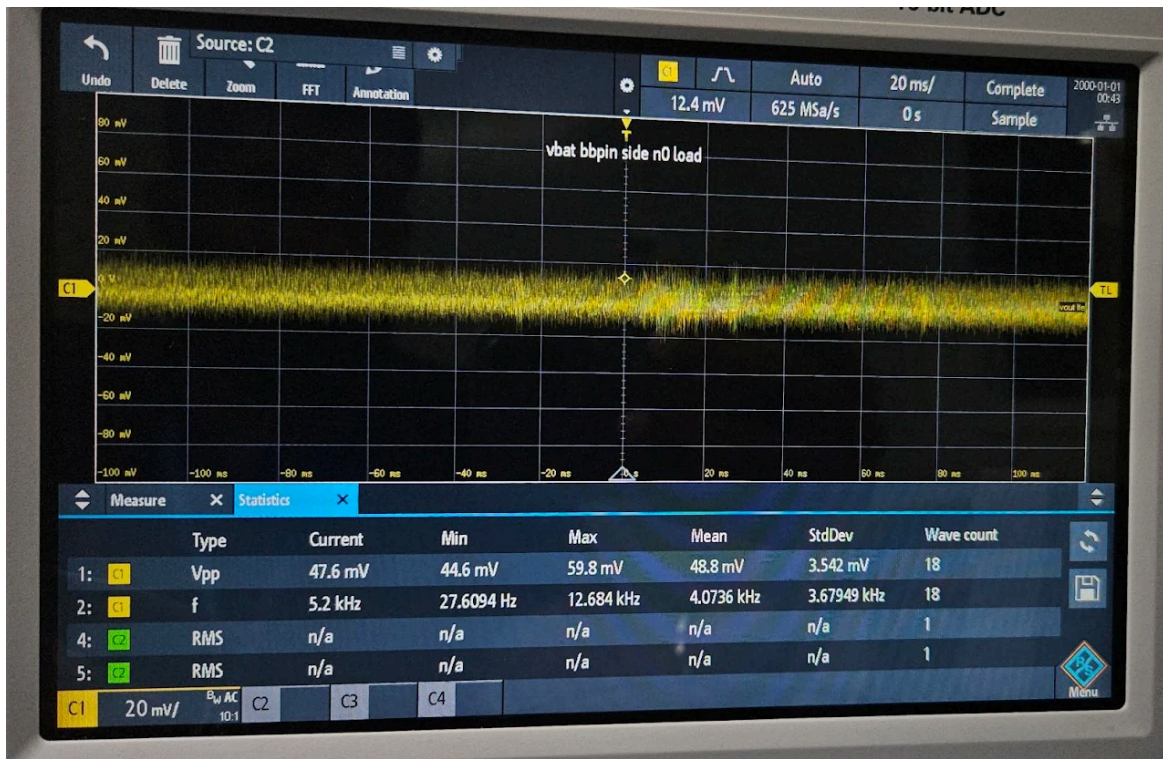

At full load:



Transient response

Here the LTE load current (green channel), Buck Vout(Yellow channel) probed from source side is shown. Yellow channel have an offset of 3.8V

