



Automotive
Product Data Sheet
LTPA-C3535BWP
Preliminary

Spec No. :

Created Date: 2017/11/17

Revision: (PRELIMINARY)-6.0

BNS-OD-FC001/A4

Specific Lighting LTPA-C3535BWP(PRELIMINARY)

<u>Rev</u>	<u>Description</u>	<u>By</u>	<u>Date</u>
1.0	New data sheet	Aron	11/18/2015
2.0	1. Update Applicative 2. Package dimensions of Reel change to 10" 3. Max package number change to 1kpcs	Aron	12/11/2015
3.0	Modify Reflow Soldering Characteristics	Aron	02/01/2016
4.0	Modify Thermal Resistance	Aron	04/13/2016
5.0	Modify Application and Reliability list for Automotive	Aron Tsai	06/29/2017
6.0	Modify MSL level	Aron Tsai	11/17/2017
Above data for PD and Customer tracking only			

Customer Name:

Customer Signature:

Print Name:

LiteON Sales Signature:

Print Name:

Specific Lighting LTPA-C3535BWP(PRELIMINARY)

1. Description

The LiteOn White LED is a revolutionary, energy efficient and ultra-compact new light source, combining the lifetime and reliability advantages of Light Emitting Diodes with the brightness of conventional lighting. It gives you total design freedom and unmatched brightness, creating a new opportunities for solid state lighting to displace conventional lighting technologies

1.1 Features

- Meet RoHS and HF
- Highest brightness SMD LED
- Package in 12mm tape on 10" diameter reels.
- I.C. compatible
- Compatible with automatic placement equipment
- Compatible with infrared reflow solder process

1.2 Applications

- Automotive: accessory applications.

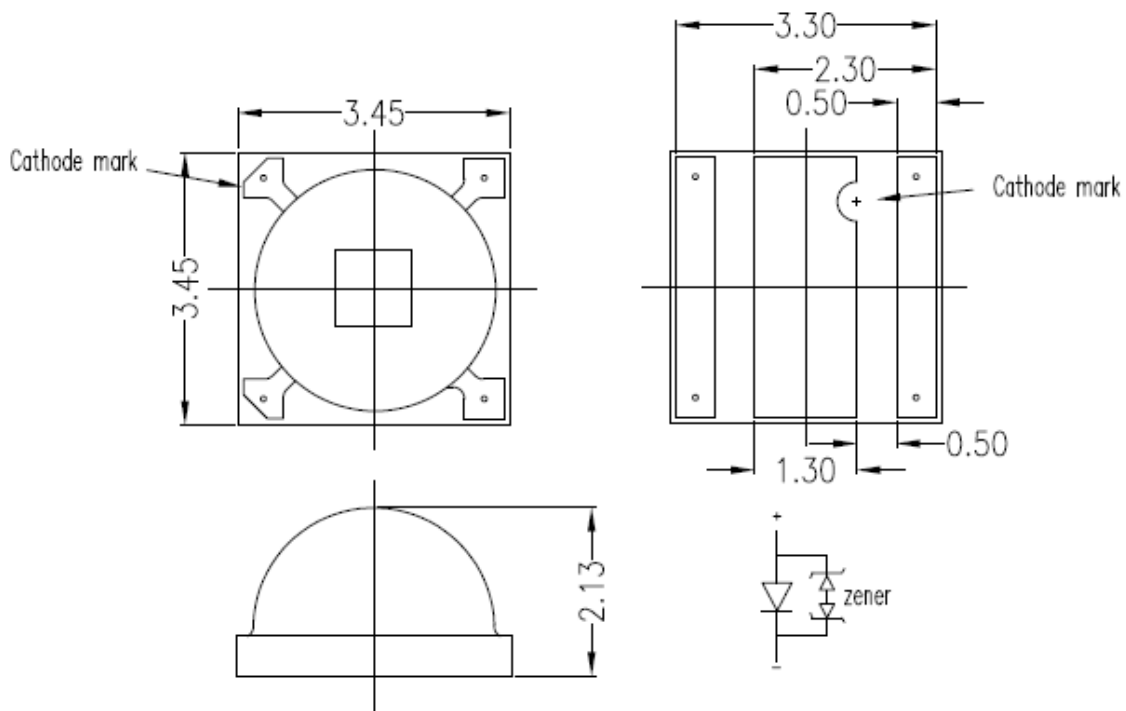

Part No.	Lens Color	Source Color
LTPA-C3535BWP	Yellow / White	InGaN White

Notes:

1. All dimensions are in millimeters and dimension tolerances are $\pm 0.3\text{mm}$
2. Dimensions without tolerances are for reference only.

Specific Lighting LTPA-C3535BWP(PRELIMINARY)

2. Rating and Characteristics

2.1 Absolute Maximum Ratings at Ta=25°C

Parameter	Symbol	Rating	Unit
Power Dissipation	Po	1.7	W
DC Forward Current	IF	500	mA
ESD Sensitivity(HBM)	VHBM	8	kV
Junction Temperature	Tj	125	°C
Thermal Resistance, Junction-Case	Rth, J-C	40	°C / W
Operating Temperature Range	Topr	-40~+100	°C
Storage Temperature Range	Tstg	-40~+100	°C

Notes :

1. The pulse mode condition is 1 KHz with 0.1msec pulse width..
2. Forbid to operating at reverse voltage condition
3. ESD spec is reference to AEC-Q101-001 HBM.
4. The unit of Rth is °C/W electrical and driving current is 350mA.
5. Thermal resistance measurement tolerance is ± 10%,and with 8x 6 cm heat sink.
6. The package LEDs are not designed to be driven in reverse bias

Specific Lighting LTPA-C3535BWP(PRELIMINARY)

2.2 Electro-Optical Characteristics

■ Typical Performance for white (Ta= 25°C)

Parameter	Symbol	Values			Unit	Test Condition
		Min	Typ.	Max		
Correlated Color Temperature	CCT	--	6000	--	K	I _F = 350mA
Color Rendering Index	CRI	--	70	--	-	
Viewing Angle	2θ _{1/2}	--	118	--	deg	
Forward Voltage	V _F	2.8	3.1	3.6	V	
Luminous Flux	Φ _V	90		150	lm	

Notes

1. All of the VF value are typical and the real bin range please refer "VF Binning Parameter".
2. All of the Flux value are typical and the real Bin range please refer "Flux Binning Parameter".
3. Tolerance of Flux is ±10%, Tolerance of VF is ±5%, tolerance of CCx/CCy is ±0.01, tolerance of CRI is ±3.,
4. LEDs are lighted up and measured with externally parallel connecting leads of LED.
5. Typical viewing angle is 118deg.

Specific Lighting LTPA-C3535BWP(PRELIMINARY)

3. Typical Electrical/Optical Characteristics Curve

■ Efficiency Comparison Table

3.1 Relative Spectrum of Emission

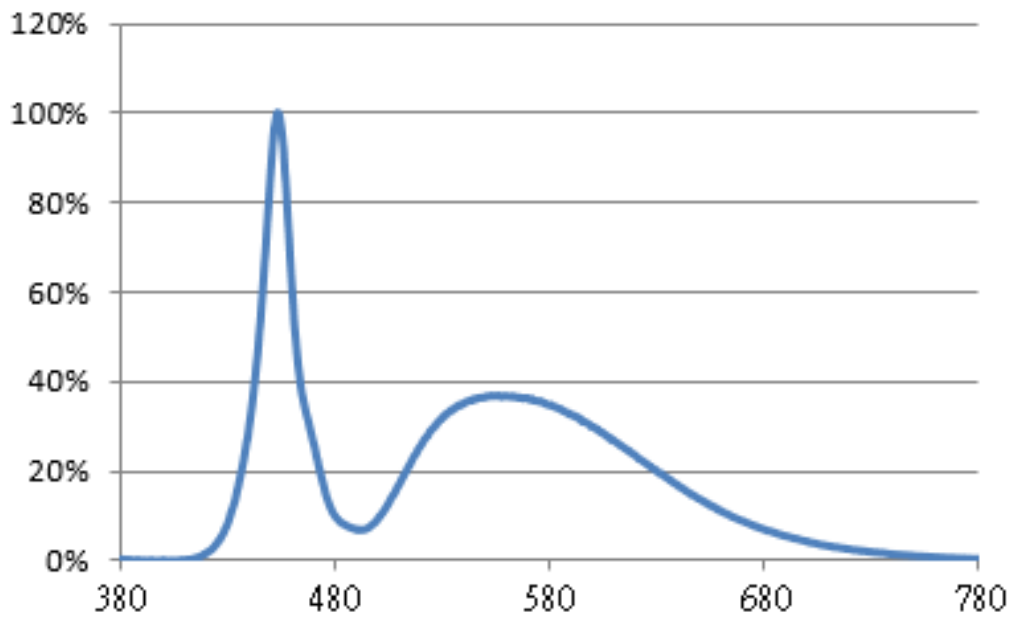

3.2 Relative Flux vs. Current

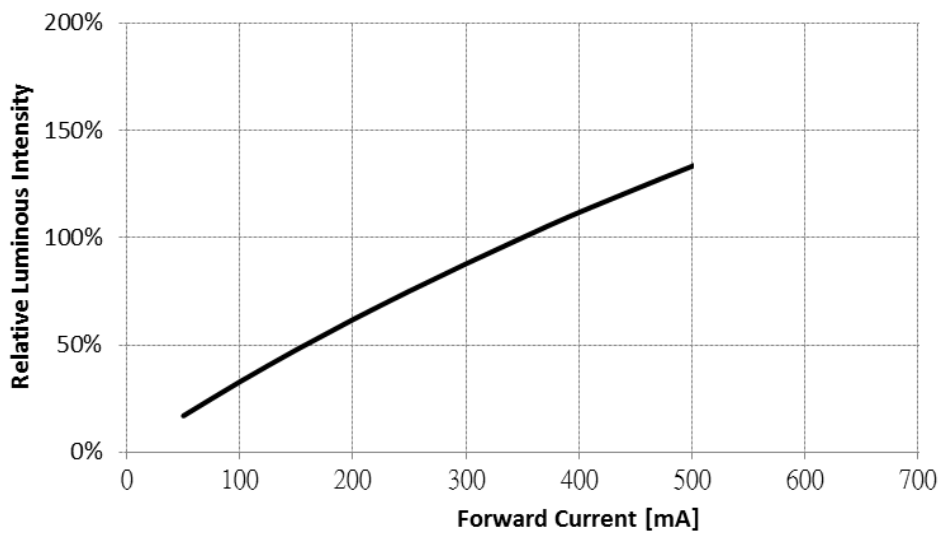

Fig 1. Typical relative luminous flux vs. forward current

Specific Lighting LTPA-C3535BWP(PRELIMINARY)

3.3 Beam Pattern

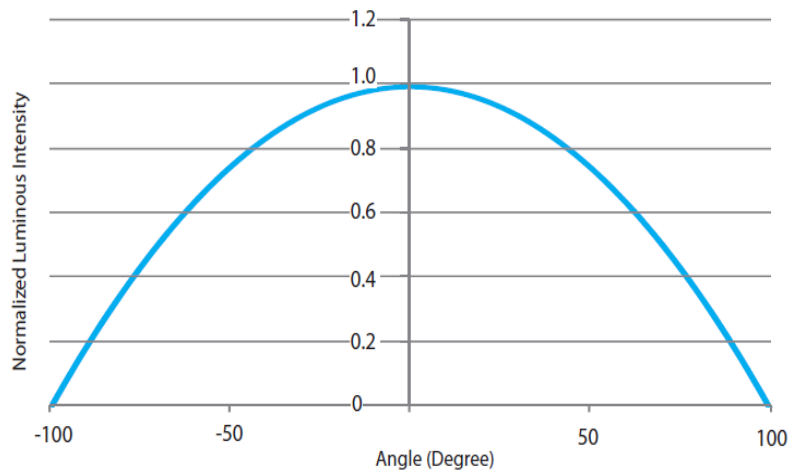

Fig 2. Emission angle

3.4 Forward Current vs. Forward Voltage at 25°C

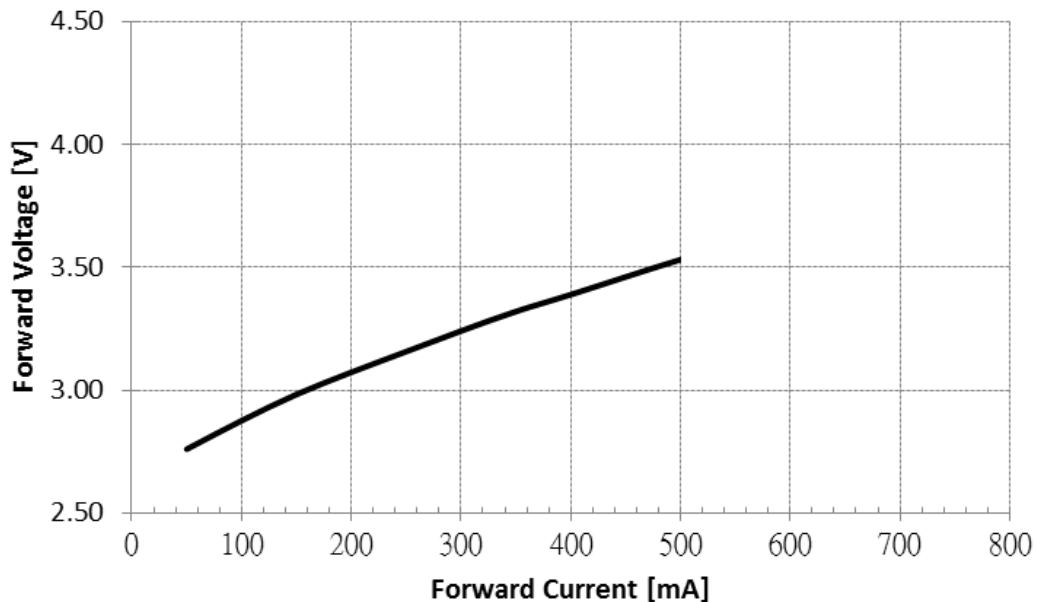
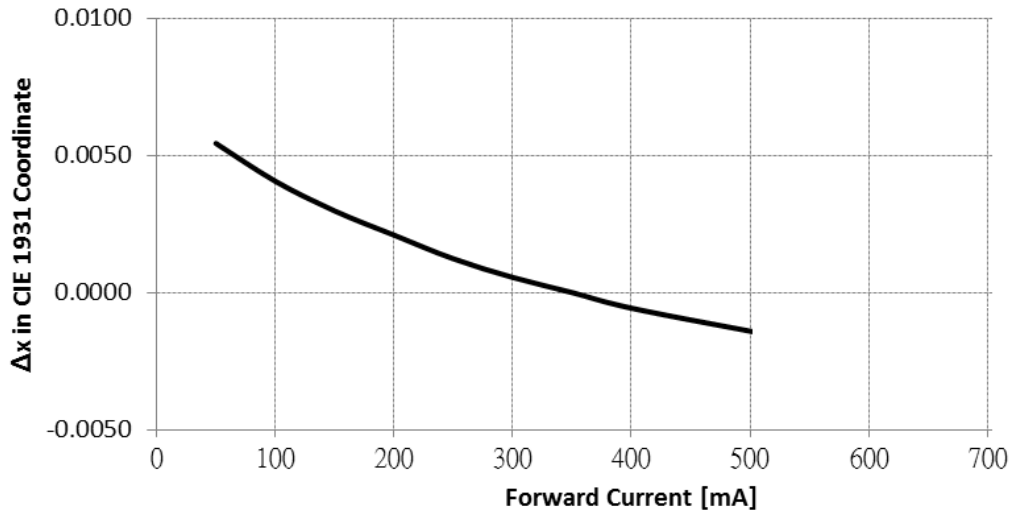

Fig 3. Forward Current vs. Forward Voltage

Specific Lighting LTPA-C3535BWP(PRELIMINARY)

3.5 Relative CCx v.s. Forward Current at 25°C



3.6 Relative CCy v.s. Forward Current at 25°C

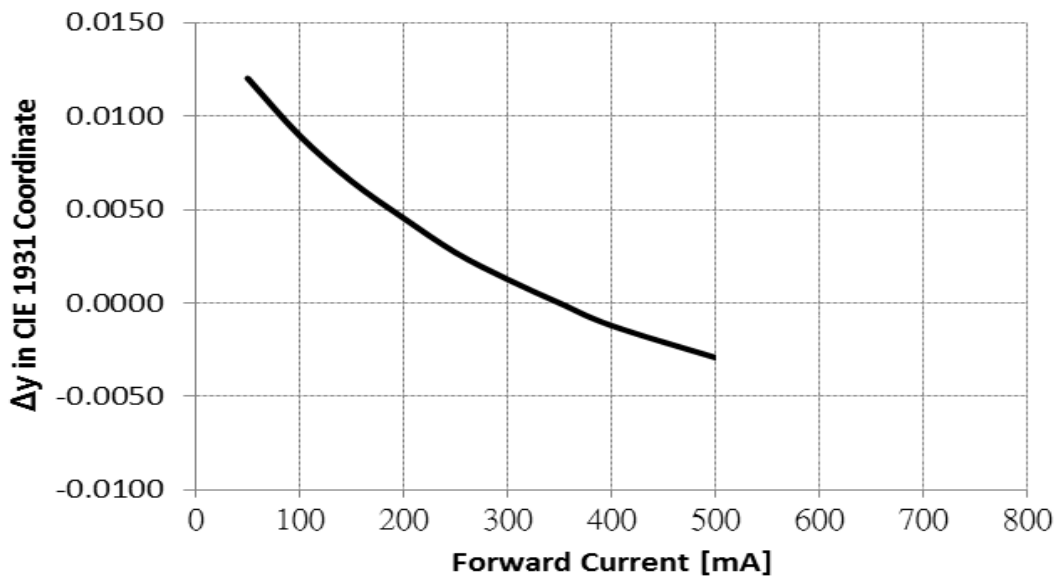

Specific Lighting LTPA-C3535BWP(PRELIMINARY)

3.7 Forward Current vs. Ambient Temperature

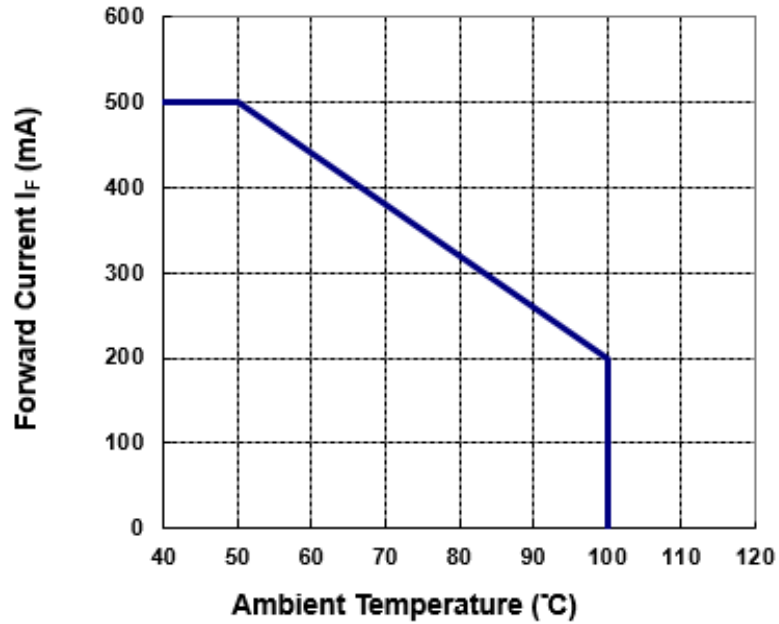

Specific Lighting LTPA-C3535BWP(PRELIMINARY)

4. VF Bin Definition

4.1 Forward Voltage Binning Parameter at Ta = 25°C

Parameter	Bin	Symbol	Min	Max	Unit	Condition
Forward Voltage	C	VF	2.8	3.0	V	I _F = 350mA
	D		3.0	3.2		
	E		3.2	3.4		
	F		3.4	3.6		

Tolerance on each Forward Voltage bin is ±5%

5. Flux Bin Definition

5.1 Luminous Flux Binning Parameter at Ta = 25°C

Parameter	Bin	Symbol	Min	Max	Unit	condition
Luminous Flux	S0	ΦV	90	105	lm	I _F = 350mA
	S1		105	120		
	S2		120	135		
	S3		135	150		

Tolerance on each Luminous Flux bin is ±10%

Specific Lighting LTPA-C3535BWP(PRELIMINARY)

6. Hue Bin Definition

6.1 Chromaticity Coordinate Groups at Ta=25°C

6.1.1 Cool White hue point (CW series)

C3535 hue for cool white family															
Code	-	x	y	Code	-	x	y	Code	-	x	y	Code	-	x	y
CW1	1	0.2950	0.2970	CW2	1	0.292	0.306	CW3	1	0.2984	0.3133	CW4	1	0.2984	0.3133
	2	0.2920	0.3060		2	0.2895	0.3135		2	0.2962	0.322		2	0.3048	0.3207
	3	0.2984	0.3133		3	0.2962	0.322		3	0.3028	0.3304		3	0.3068	0.3113
	4	0.3009	0.3042		4	0.2984	0.3133		4	0.3048	0.3207		4	0.3009	0.3042
CW5	1	0.2980	0.2880	CW6	1	0.2895	0.3135	CW7	1	0.2962	0.3220	CW8	1	0.3037	0.2937
	2	0.2950	0.2970		2	0.2870	0.3210		2	0.2937	0.3312		2	0.3009	0.3042
	3	0.3009	0.3042		3	0.2937	0.3312		3	0.3005	0.3415		3	0.3068	0.3113
	4	0.3037	0.2937		4	0.2962	0.3220		4	0.3028	0.3304		4	0.3093	0.2993
CW9	1	0.3048	0.3207	CW10	1	0.3028	0.3304	CW11	1	0.3115	0.3391	CW12	1	0.3130	0.3290
	2	0.3130	0.3290		2	0.3115	0.3391		2	0.3205	0.3481		2	0.3213	0.3373
	3	0.3144	0.3186		3	0.3130	0.3290		3	0.3213	0.3373		3	0.3221	0.3261
	4	0.3068	0.3113		4	0.3048	0.3207		4	0.3130	0.3290		4	0.3144	0.3186
CW13	1	0.3068	0.3113	CW14	1	0.3005	0.3415	CW15	1	0.3099	0.3509	CW16	1	0.3144	0.3186
	2	0.3144	0.3186		2	0.3099	0.3509		2	0.3196	0.3602		2	0.3221	0.3261
	3	0.3161	0.3059		3	0.3115	0.3391		3	0.3205	0.3481		3	0.3231	0.3120
	4	0.3093	0.2993		4	0.3028	0.3304		4	0.3115	0.3391		4	0.3161	0.3059
CW17	1	0.3215	0.3350	CW18	1	0.3207	0.3462	CW19	1	0.3290	0.3538	CW20	1	0.3290	0.3417
	2	0.3290	0.3417		2	0.3290	0.3538		2	0.3376	0.3616		2	0.3371	0.3490
	3	0.3290	0.3300		3	0.3290	0.3417		3	0.3371	0.3490		3	0.3366	0.3369
	4	0.3222	0.3243		4	0.3215	0.3350		4	0.3290	0.3417		4	0.3290	0.3300
CW21	1	0.3222	0.3243	CW22	1	0.3196	0.3602	CW23	1	0.3290	0.3690	CW24	1	0.3290	0.3300
	2	0.3290	0.3300		2	0.3290	0.3690		2	0.3381	0.3762		2	0.3366	0.3369
	3	0.3290	0.3180		3	0.3290	0.3538		3	0.3376	0.3616		3	0.3361	0.3245
	4	0.3231	0.3120		4	0.3207	0.3462		4	0.3290	0.3538		4	0.3290	0.3180
CW25	1	0.3371	0.3490	CW26	1	0.3376	0.3616	CW27	1	0.3463	0.3687	CW28	1	0.3451	0.3554
	2	0.3451	0.3554		2	0.3463	0.3687		2	0.3551	0.3760		2	0.3533	0.3620
	3	0.3440	0.3427		3	0.3451	0.3554		3	0.3533	0.3620		3	0.3515	0.3487
	4	0.3366	0.3369		4	0.3371	0.3490		4	0.3451	0.3554		4	0.3440	0.3427
CW29	1	0.3366	0.3369	CW30	1	0.3381	0.3762	CW31	1	0.3480	0.3840	CW32	1	0.3440	0.3428
	2	0.3440	0.3428		2	0.3480	0.3840		2	0.3571	0.3907		2	0.3515	0.3487
	3	0.3429	0.3307		3	0.3463	0.3687		3	0.3551	0.3760		3	0.3495	0.3339
	4	0.3361	0.3245		4	0.3376	0.3616		4	0.3463	0.3687		4	0.3429	0.3307
CW33	1	0.3530	0.3597	CW34	1	0.3548	0.3736	CW35	1	0.3641	0.3804	CW36	1	0.3615	0.3659
	2	0.3615	0.3659		2	0.3641	0.3804		2	0.3736	0.3874		2	0.3702	0.3722
	3	0.3590	0.3521		3	0.3615	0.3659		3	0.3702	0.3722		3	0.3670	0.3578
	4	0.3512	0.3465		4	0.3530	0.3597		4	0.3615	0.3659		4	0.3590	0.3521
CW37	1	0.3512	0.3465	CW38	1	0.3571	0.3907	CW39	1	0.3668	0.3957	CW40	1	0.3590	0.3521
	2	0.3590	0.3521		2	0.3668	0.3957		2	0.3771	0.4034		2	0.3670	0.3578
	3	0.3567	0.3389		3	0.3641	0.3804		3	0.3736	0.3874		3	0.3640	0.3440
	4	0.3495	0.3339		4	0.3548	0.3736		4	0.3641	0.3804		4	0.3567	0.3389

Tolerance of each hue bin is ±0.01

Specific Lighting LTPA-C3535BWP(PRELIMINARY)

6.1.2 Cool white hue range

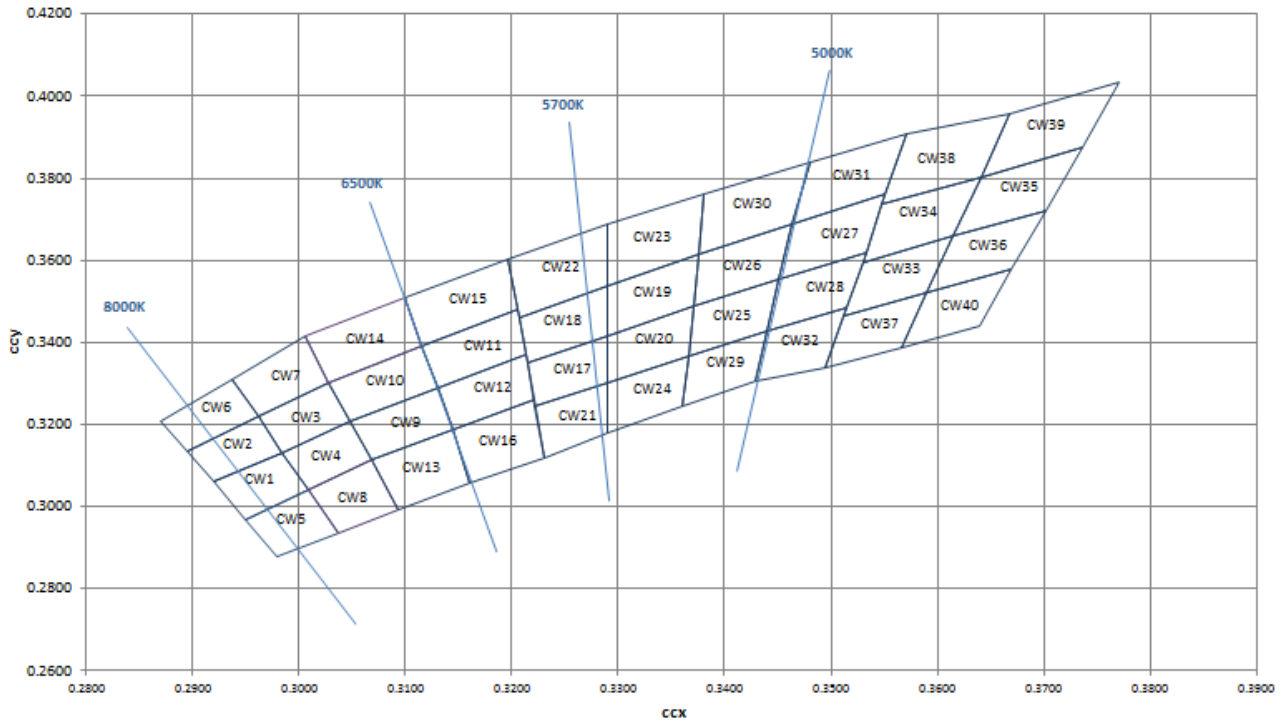

Notes

1. The (CCx, CCy) center follow ANSI Quadrangle

Specific Lighting LTPA-C3535BWP(PRELIMINARY)

7. Recommend Soldering Pad Layout

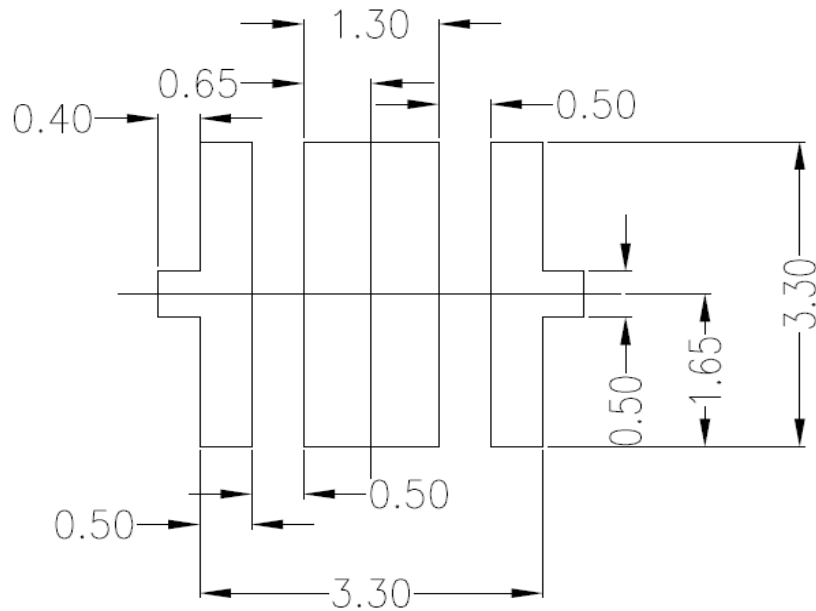
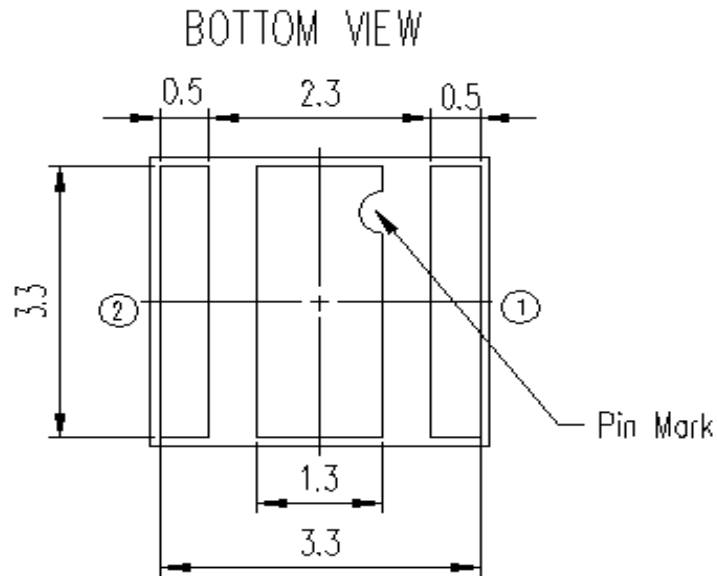

Notes:

1. Suggest stencil thickness is maximum 0.10mm

Specific Lighting LTPA-C3535BWP(PRELIMINARY)

8. Reflow Soldering Characteristics

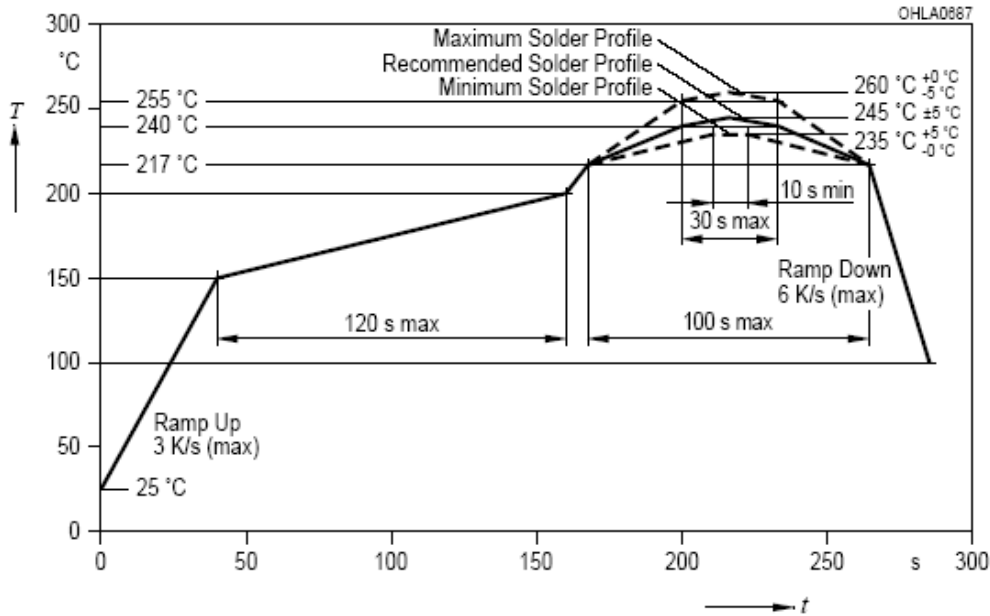

Notes

1. All temperatures refer to topside of the package, measured on the package body surface.
2. The soldering profile could be further referred to different soldering grease material characteristic. The grease vendor will provide this information.
3. A rapid-rate process is not recommended for the LEDs cooling down from the peak temperature.
4. Although the recommended reflow conditions are specified above, the reflow condition at the lowest possible temperature is desirable for the LEDs.
5. LiteOn cannot make a guarantee on the LEDs which have been already assembled using the dip soldering Method

Specific Lighting LTPA-C3535BWP(PRELIMINARY)

9. Reliability Test

No	Test item	Test Condition	Duration	Number of Damaged
1	Pre-conditional	MSL 2 125°C, 24hrs baking Moisture Soak 85°C/60% 168hrs Interval: 15mins~4hours to do IR-Reflow	Before and after	Qualification parts before Test # 2, 3, 4, 5, 6
2	High Temperature Operating Life I	IF=500mA, Ta=50°C, 1000 hrs	1000 hrs	0/30
3	High Temperature Operating Life II	Ta=100°C., IF=200mA, 1000 hrs	1000 hrs	0/30
4	High Temperature High Humidity Bias (HTHHB)	Ta=60°C, Rh=90%, IF=400mA, 1000 hrs	1000 hrs	0/30
5	Temperature Cycle I	-40°C ± 5°C ~ 100 ± 5°C 30min 30min Transfer time <= 1min, 500cycles	500 cycle	0/30
6	Temperature Cycle II	-40°C ~ 25°C ~ 100°C ~ 25°C 30min 5min 30min 5min 500cycles	500 cycle	0/30
7	Resistance to Soldering Heat	(1) Bake 125°C / 24 hours (2) Acceleration moisture soak condition (if urgent): 60°C / 60% / 52 hours (Interval: 15mins ~ 4 hours to do IR-Reflow) (3) IR Reflow 2 times (260°C: 10 secs, Interval: 5 mins ~ 60 mins for each reflow)	Before and after	0/30
8	Solderability	Tsld=245± 5°C	Before and after	0/11

Specific Lighting LTPA-C3535BWP(PRELIMINARY)

10. Package Dimensions of Tape and Reel

Reel Packaging

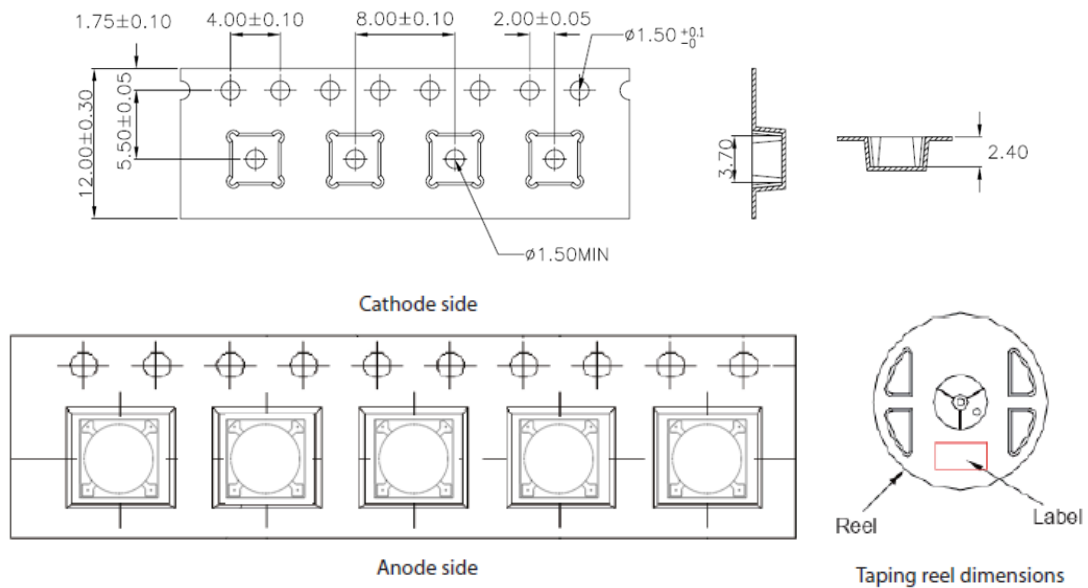

Note:

1. All dimensions are in millimeters.
2. Empty component pockets sealed with top cover tape.
3. Minimum package quality is 500 pieces for remainders.
4. 10 inch reel max 1k pieces.
5. The maximum number of consecutive missing is two.
6. In accordance with ANSI/EIA 481 specifications.

Specific Lighting LTPA-C3535BWP(PRELIMINARY)

11. Cautions

11.1 An LED is a current-operated device. In order to ensure intensity uniformity on multiple LEDs connected in parallel in an application, it is recommended that a current limiting resistor be incorporated in the drive circuit, in series with each LED as shown in Circuit below.

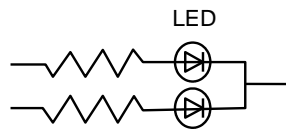

Circuit model A

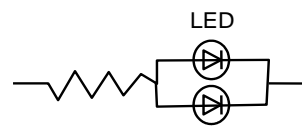

Circuit model B

(A) Recommended circuit.

(B) The brightness of each LED might appear different due to the differences in the I-V characteristics of those LEDs.

11.2 Do not put any pressure on the light emitting surface either by finger or any hand tool and do not stack the COB products. Stress or pressure may cause damage to the wires of the LED array.

11.3 This product is not designed for the use under any of the following conditions, please confirm the performance and reliability are well enough if you use it under any of the following conditions

- Do not use sulfur-containing materials in commercial products including the materials such as seals and adhesives that may contain sulfur.
- Do not put this product in a place with a lot of moisture (over 85% relative humidity), dew condensation, briny air, and corrosive gas (Cl, H₂S, NH₃, SO₂, NO_x, etc.), exposure to a corrosive environment may affect silver plating.

ESD (Electrostatic Discharge)

Static Electricity or power surge will damage the LED. Suggestions to prevent ESD damage:

- Use of a conductive wrist band or anti-electrostatic glove when handling these LEDs.
- All devices, equipment, and machinery must be properly grounded.
- Work tables, storage racks, etc. should be properly grounded.
- Use ion blower to neutralize the static charge which might have built up on surface of the LED's plastic lens as a result of friction between LEDs during storage and handling.

ESD-damaged LEDs will exhibit abnormal characteristics such as high reverse leakage current, low forward voltage, or "no light up" at low currents.

To verify for ESD damage, check for "light up" and VF of the suspect LEDs at low currents.

Specific Lighting LTPA-C3535BWP(PRELIMINARY)

■ Lens Handling Remark

The LED should only be picked up by making contact with the sides of the LED body. It should not put any pressure on the lens either by finger or any hand tool. Do not puncture or push the lens. Below figure illustrate correct and incorrect handling.

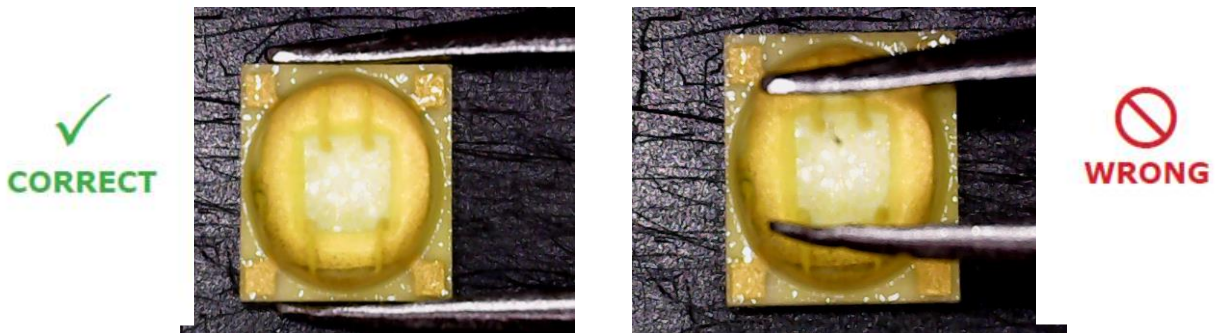

The scrape on lens is acceptable but no effect about the RA test result.

■ Storage

- This product is qualified as Moisture sensitive Level 2 per JEDEC J-STD-020 Precaution when handing this moisture sensitive product is important to ensure the reliability of the product.
- The package is sealed:
The LEDs should be stored at 30°C or less and 90%RH or less. And the LEDs are limited to use within one year, while the LEDs is packed in moisture-proof package with the desiccants inside.
- The package is opened:
The storage ambient for the LEDs should not exceed 30°C temperature or 60% relative humidity. It is recommended that LEDs out of their original packaging are IR-reflowed within one year. For extended storage out of their original packaging, it is recommended that the LEDs be stored in a sealed container with appropriate desiccant, or in a desiccators with nitrogen ambient. LEDs stored out of their original packaging for more than one year should be baked at about 60 deg C for at least 20 hours before solder assembly.