

Efficiencies:
 Buck 1, 2, 3: 90%
Drop Out Voltage:
 LDO1 & LDO2: 150mV(300mV Max)
 LDO3 & LDO4: 150mV(300mV Max)

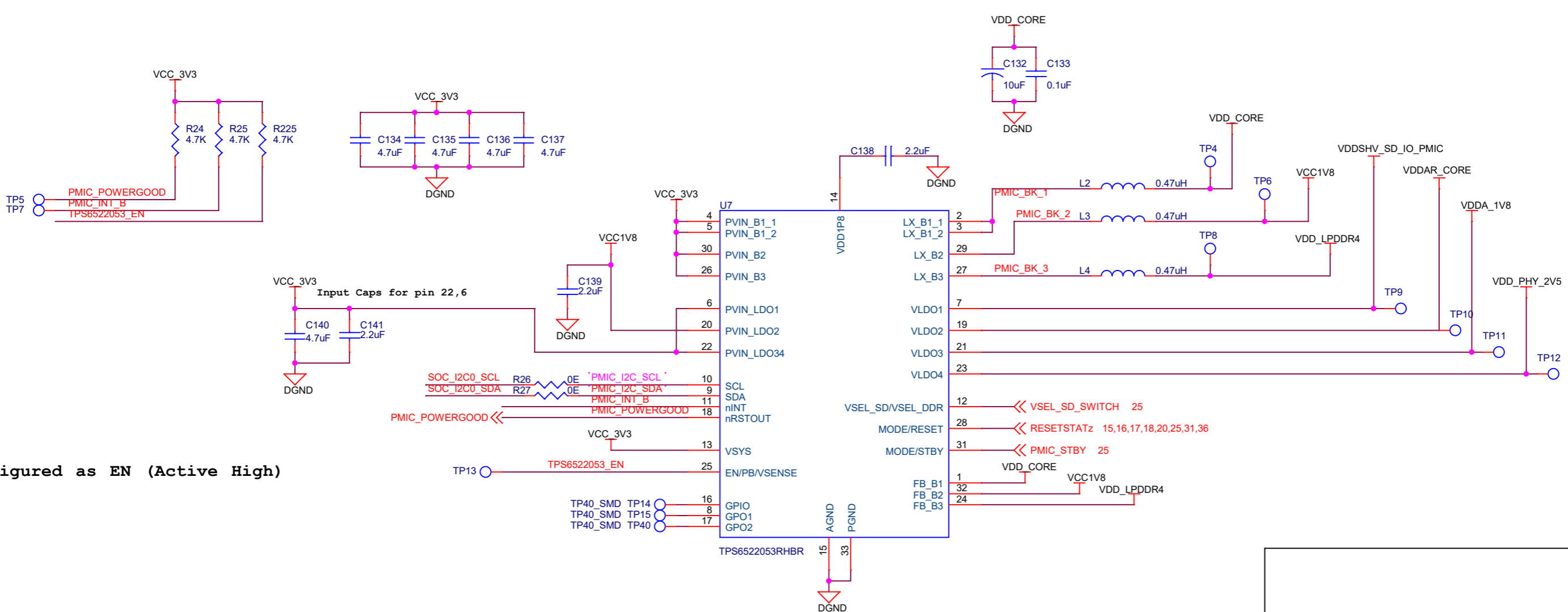

Configured as EN (Active High)

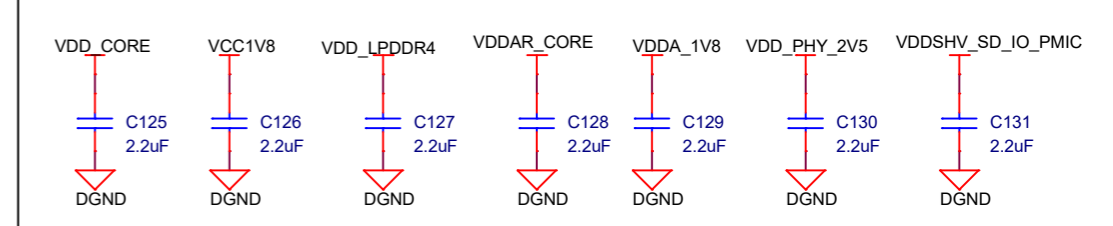
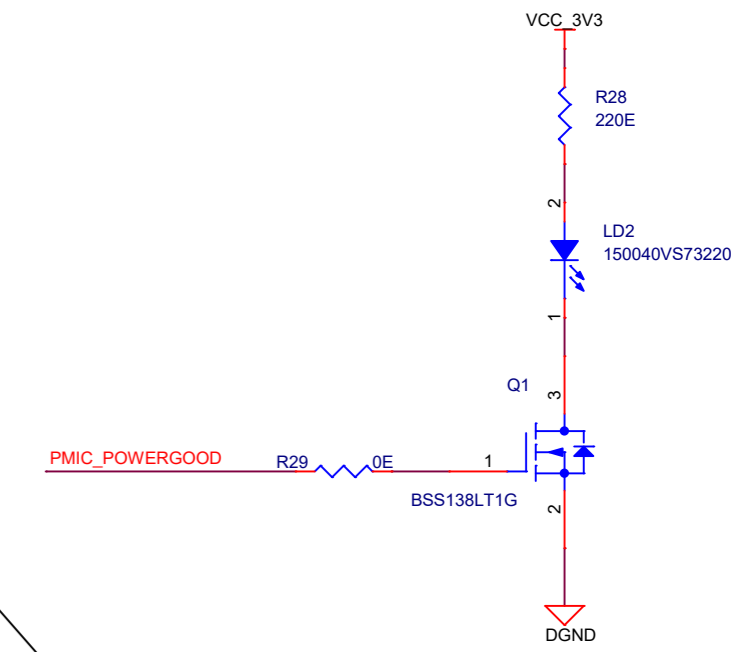
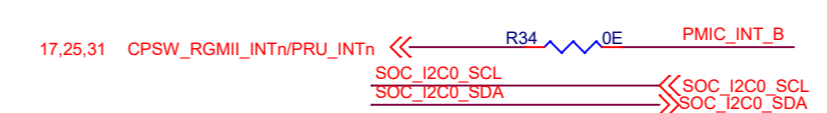
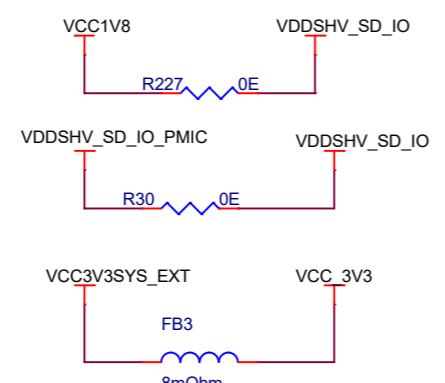
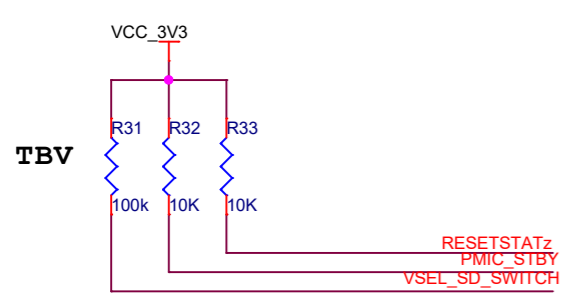

Title		<Title>
Size	Document Number	Rev
A3	<Doc>	<RevC>
Date:	Thursday, April 18, 2024	Sheet 8 of 25