

DC-DC Power Supply Module

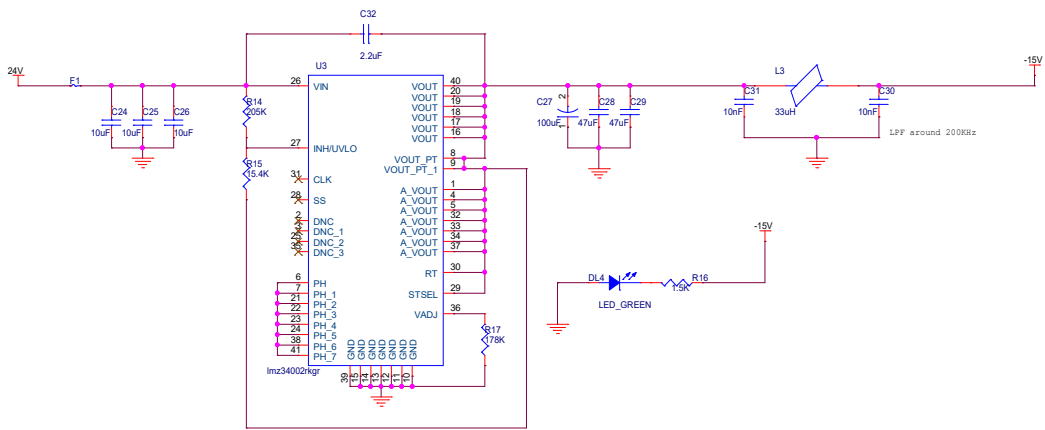
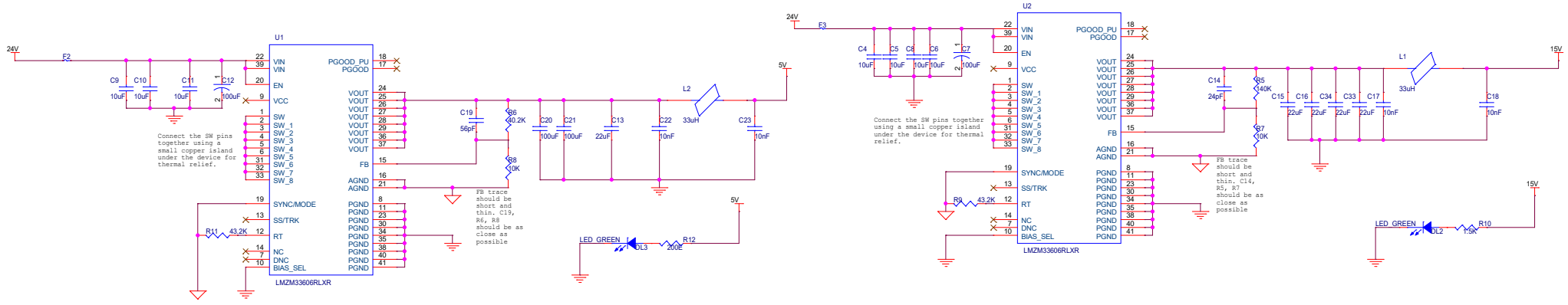
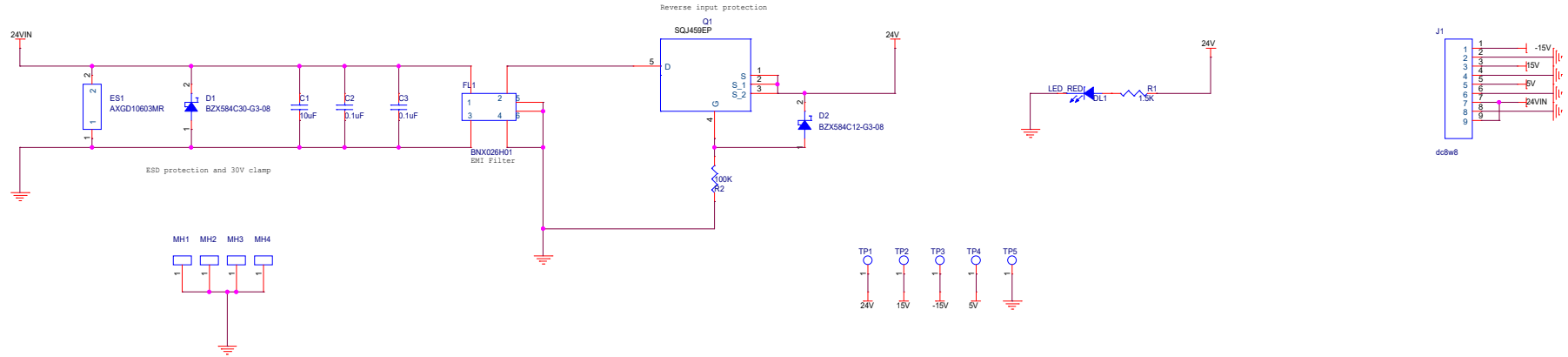

Title	<Title>		Rev	<Rev>
Size	Document Number			
C	<Doc>			
Date:	Sunday, July 25, 2021	Sheet	1 of 1	