

Power rail : VDD
Controller : LMR36006
Fswitching : 1000KHz
TDC: 0..01A MAX :0..01A
OCP : 1A(Fixed)

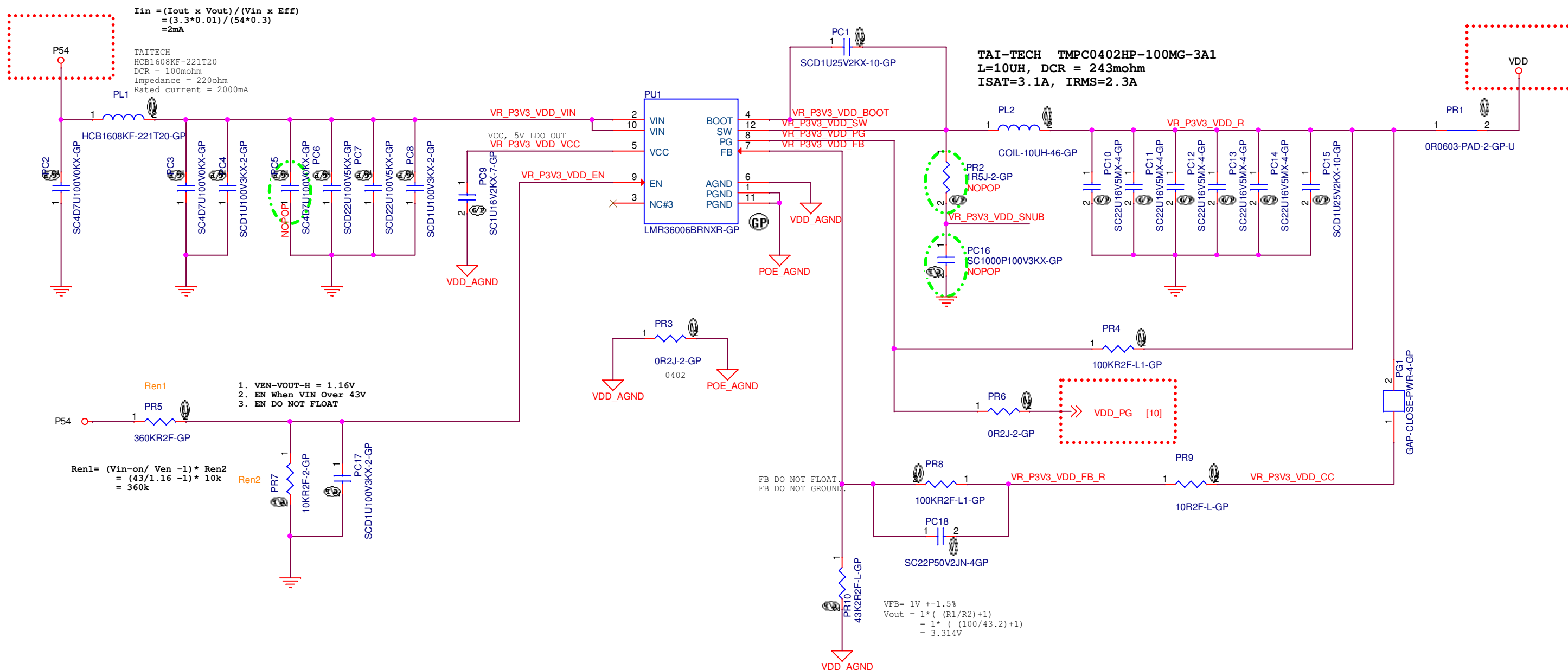

Title <Title>		
Size A3	Document Number <Doc>	Rev <RevC>
Date:	Monday, August 01, 2022	Sheet 1 of 3

Power rail : VPWR
PSE Controller : TPS23881
MOSFET : FDMS86252
Vin = 54V, Vout = 54V

A1-4 internally pulled up to VDD.
 I2C address.
 Address: TBD

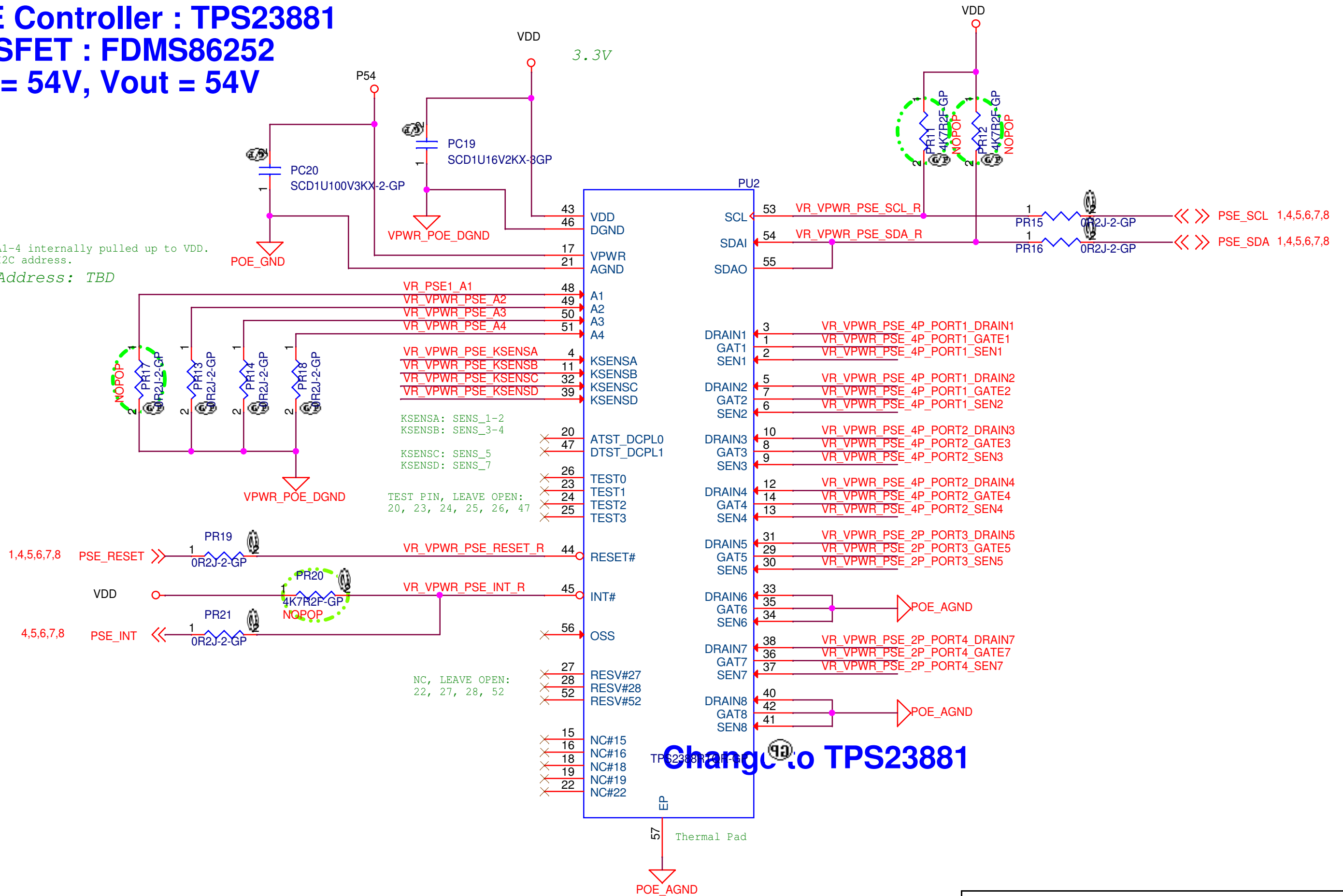

Change to TPS23881

Title		
<Title>		
Size	Document Number	Rev
A4	<Doc>	<RevCoc>
Date:	Monday, August 01, 2022	Sheet 2 of 3

Power rail : VPWR
PSE Controller : TPS23881
MOSFET : FDMS86252
Vin = 54V, Vout = 54V

P1

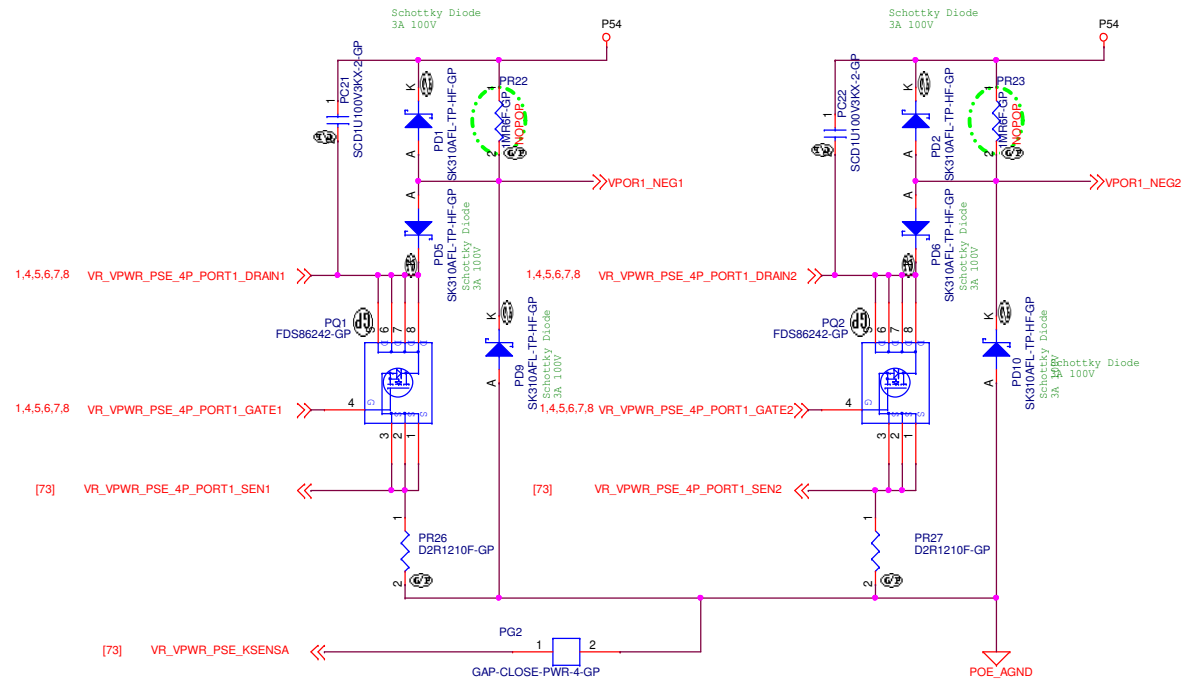

P2

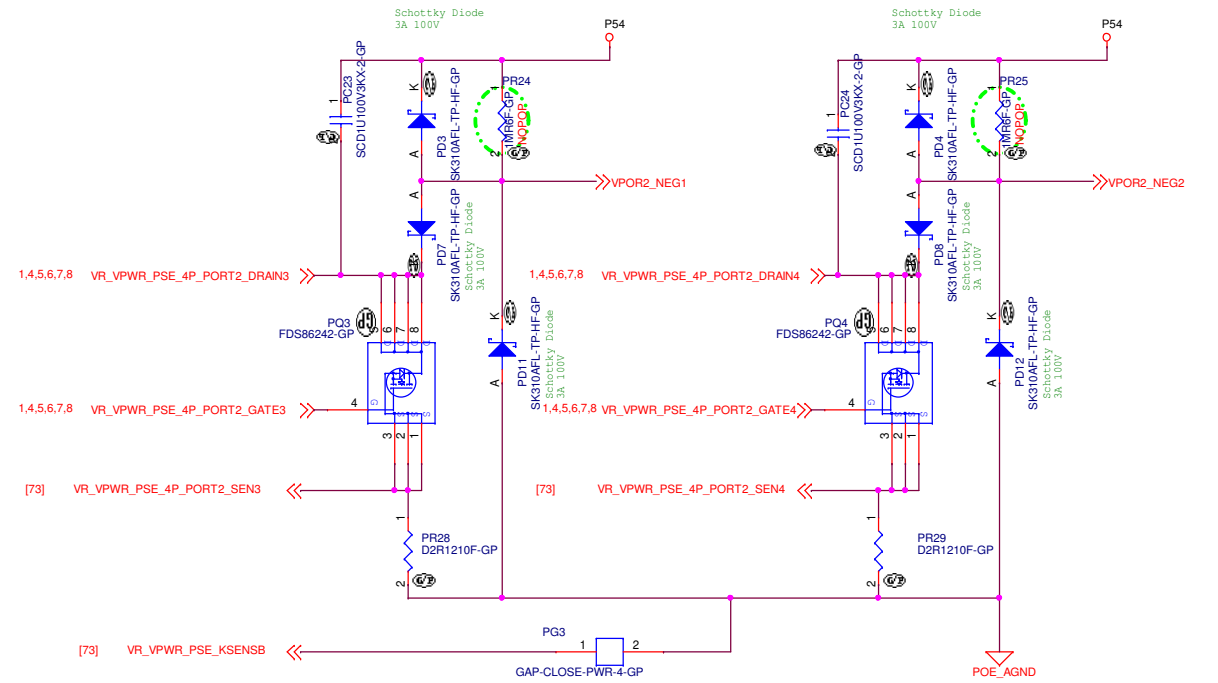

P3

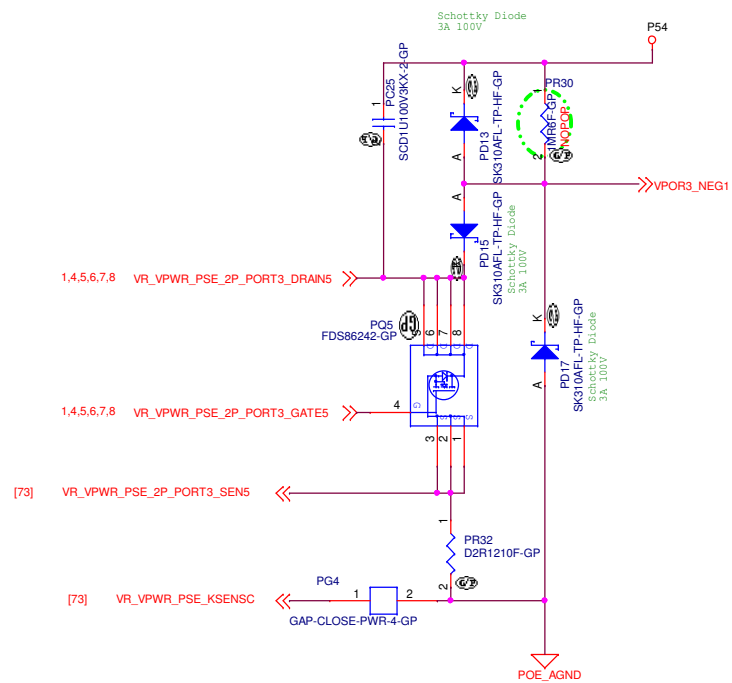

P4

