

PVNN(TPS53625RSMR)

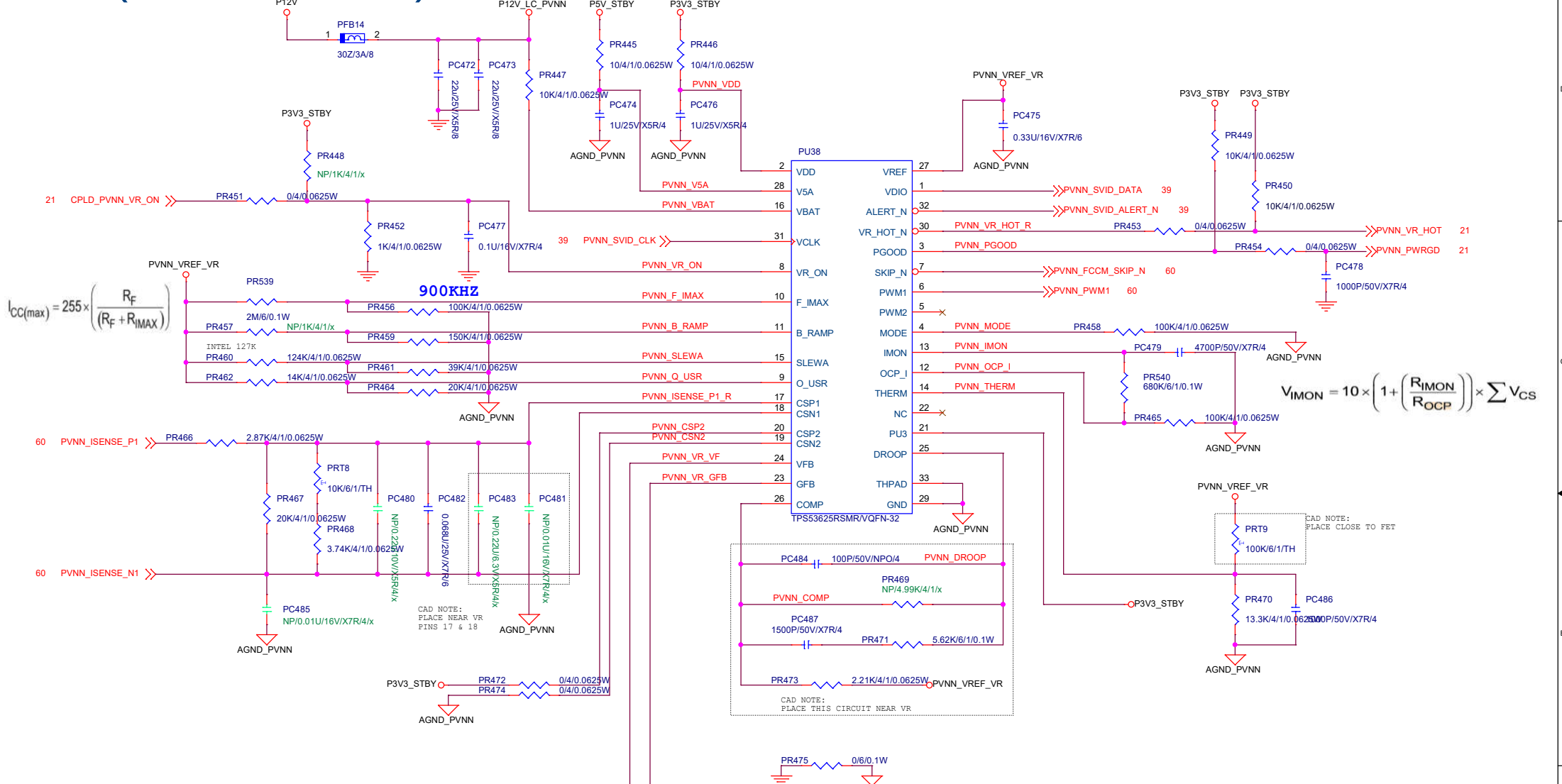

SELECTION RESISTOR (R _f) VALUE (kΩ)	OPERATING FREQUENCY (f _{sw}) (kHz)
20	300
24	400
30	500
39	600
56	700
75	800
100	900
150	1000

PVNN(CSD95379Q3M)

