



PCB Number: PWR635  
PCB Rev: A

PCB  
LOGO  
Texas Instruments

Label Table	
Variant	Label Text
001	TPS25940xEVM-635
002	TPS25942xEVM-635
003	TPS25944xEVM-635

LBL1  
PCB Label  
Size: 0.65" x 0.20"

ZZ1  
Label Assembly Note  
This Assembly Note is for PCB labels only

ZZ2  
Assembly Note  
These assemblies are ESD sensitive, ESD precautions shall be observed.

ZZ3  
Assembly Note  
These assemblies must be clean and free from flux and all contaminants. Use of no clean flux is not acceptable.

ZZ4  
Assembly Note  
These assemblies must comply with workmanship standards IPC-A-610 Class 2, unless otherwise specified.

Texas Instruments and/or its licensors do not warrant the accuracy or completeness of this specification or any information contained therein. Texas Instruments and/or its licensors do not warrant that this design will meet the specifications, will be suitable for your application or fit for any particular purpose, or will operate in an implementation. Texas Instruments and/or its licensors do not warrant that the design is production worthy. You should completely validate and test your design implementation to confirm the system functionality for your application.

Number: PWR635	Rev: A	Designed for: Public Release	Mod. Date: 4/3/2014
SVN Rev: Not in version control	Sheet: 1 of 1	Project Title: TPS2594xxEVM-635	
Drawn By: Dinesh Kumar	File: PWR635A_Hardware.SchDoc	Assembly Variant: 002	Size: B
Engineer: Dinesh Kumar	Contact: www.ti.com		



© Texas Instruments 2014

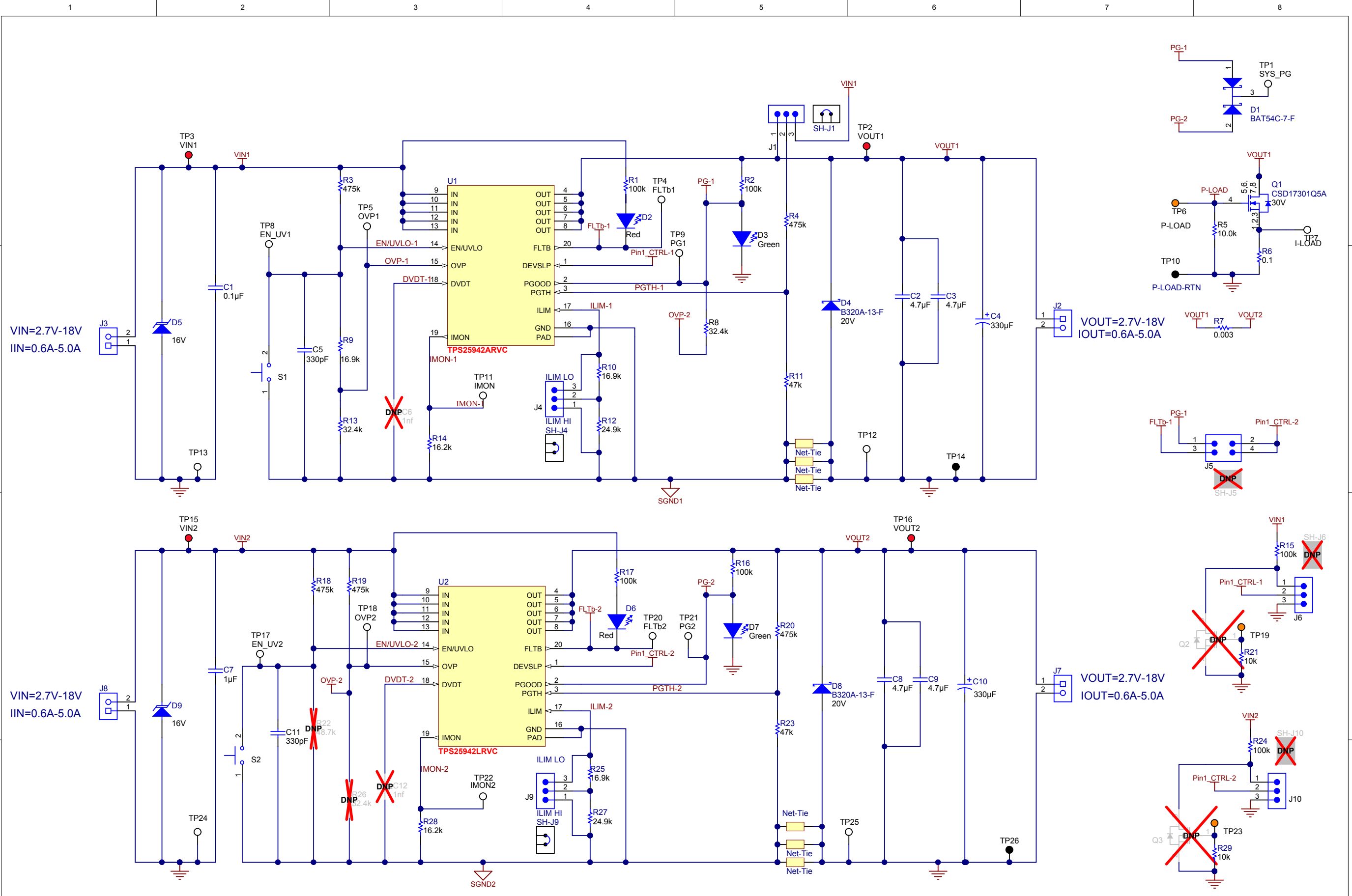

VIN=2.7V-18V  
IIN=0.6A-5.0A

VIN=2.7V-18V  
IIN=0.6A-5.0A

VOUT=2.7V-18V  
IOUT=0.6A-5.0A

VOUT=2.7V-18V  
IOUT=0.6A-5.0A

Texas Instruments and/or its licensors do not warrant the accuracy or completeness of this specification or any information contained therein. Texas Instruments and/or its licensors do not warrant that this design will meet the specifications, will be suitable for your application or fit for any particular purpose, or will operate in an implementation. Texas Instruments and/or its licensors do not warrant that the design is production worthy. You should completely validate and test your design implementation to confirm the system functionality for your application.

Number: PWR635	Rev: A	Designed for: Public Release	Mod. Date: 5/22/2014
SVN Rev: Not in version control	Sheet: 1 of 1	Project Title: TPS2594xxEVM-635	TEXAS INSTRUMENTS
Drawn By: Dinesh Kumar	File: PWR635A.SchDoc	Sheet Title:	http://www.ti.com
Engineer: Dinesh Kumar	Contact: www.ti.com	Assembly Variant: 002	© Texas Instruments 2014