

Unless otherwise indicated:
 All parts are surface mount.
 Resistors are 0603
 Capacitors are 0603

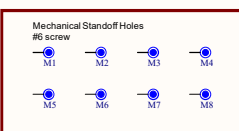
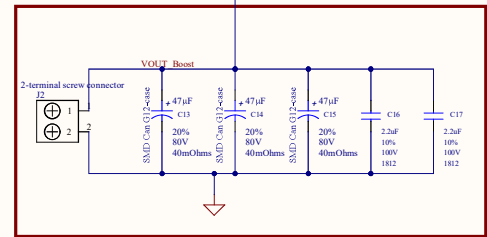
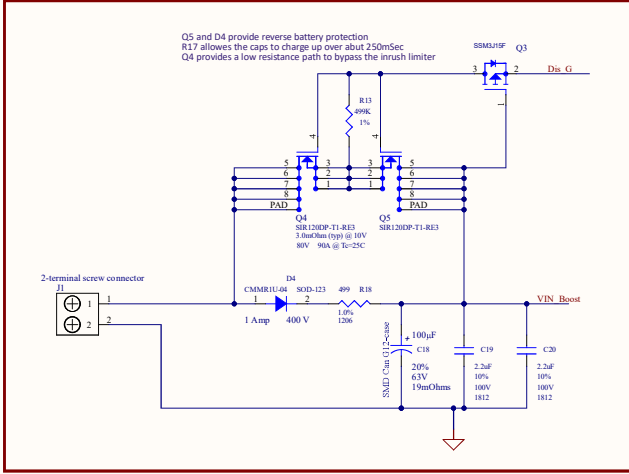
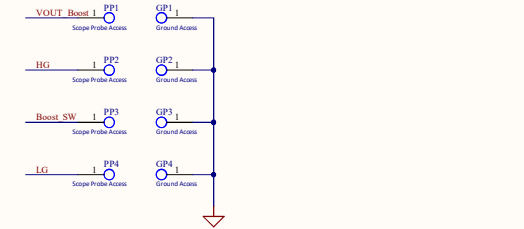
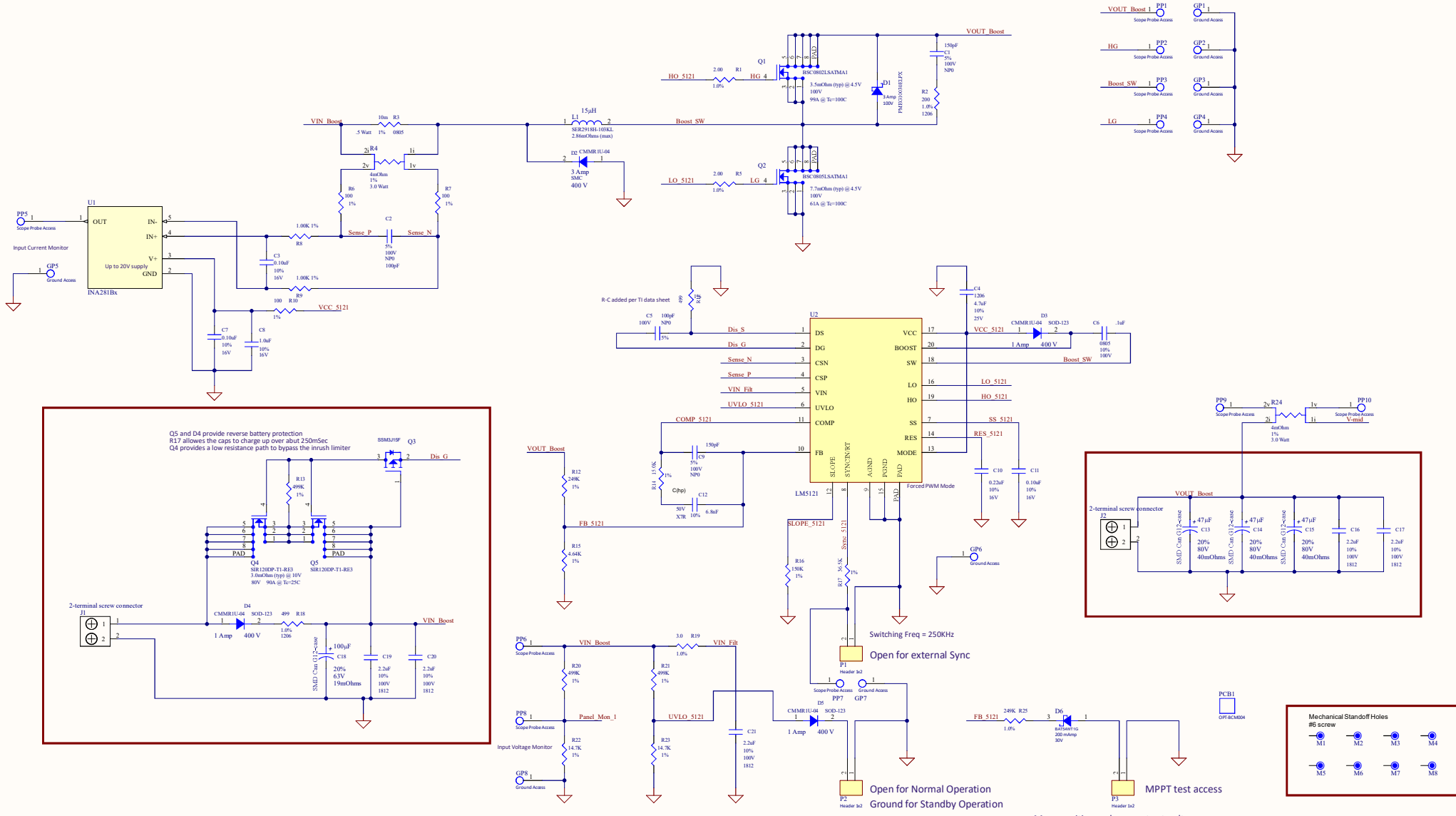

More positive reduces output voltage