

5  
 NOTA: Os valores de alguns componentes variam consoante a opção em causa. Confirmar a partir das listas de materiais respectivas.

VIN option	Fuse
dc:19V to 72V	T6.3AH250 (TBC)
dc:38V to 180V	T4AH250 (TBC)
dc:88V to 300V	T2.5AH250 (TBC)
ac:60V to 265V	

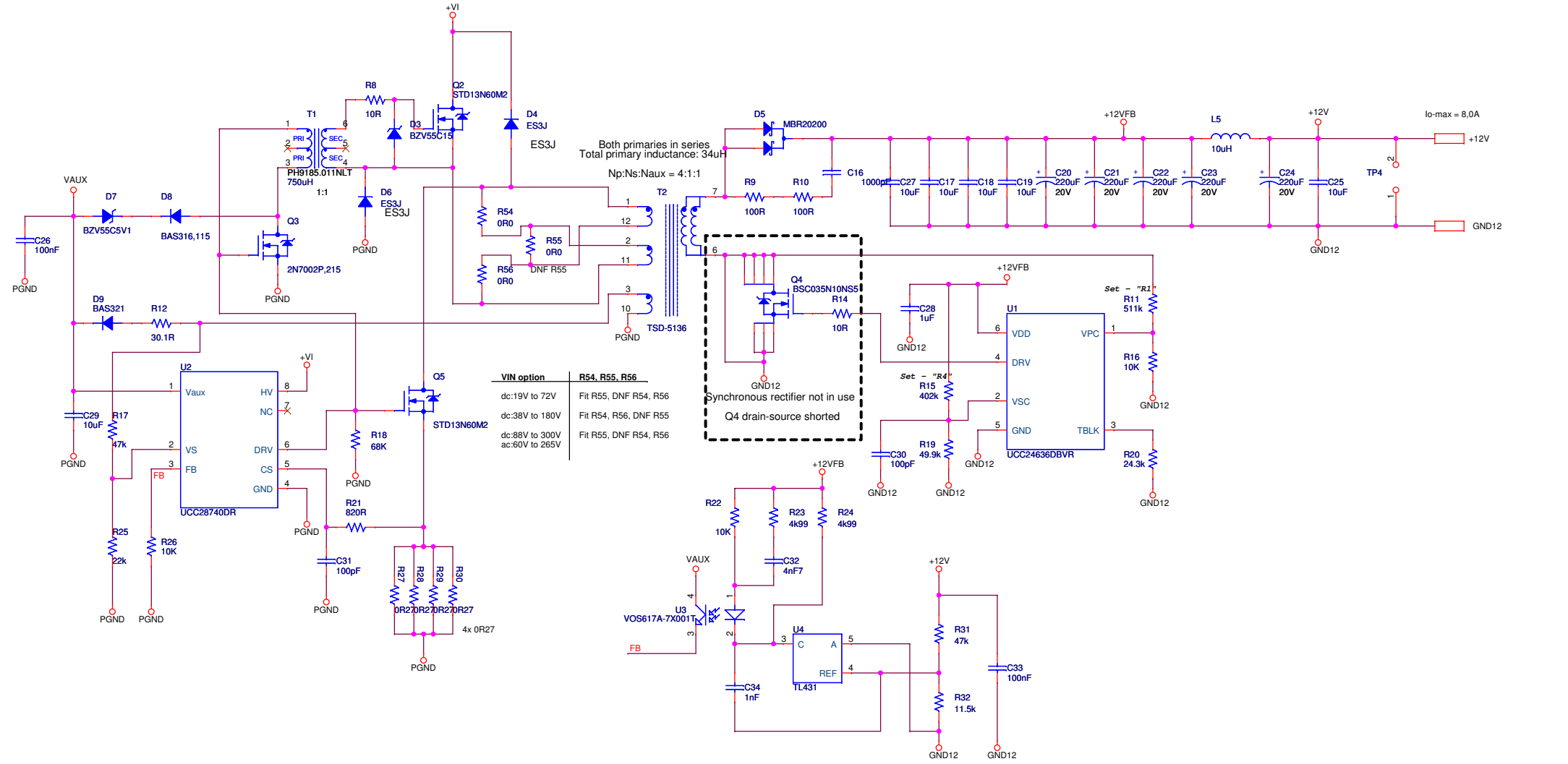
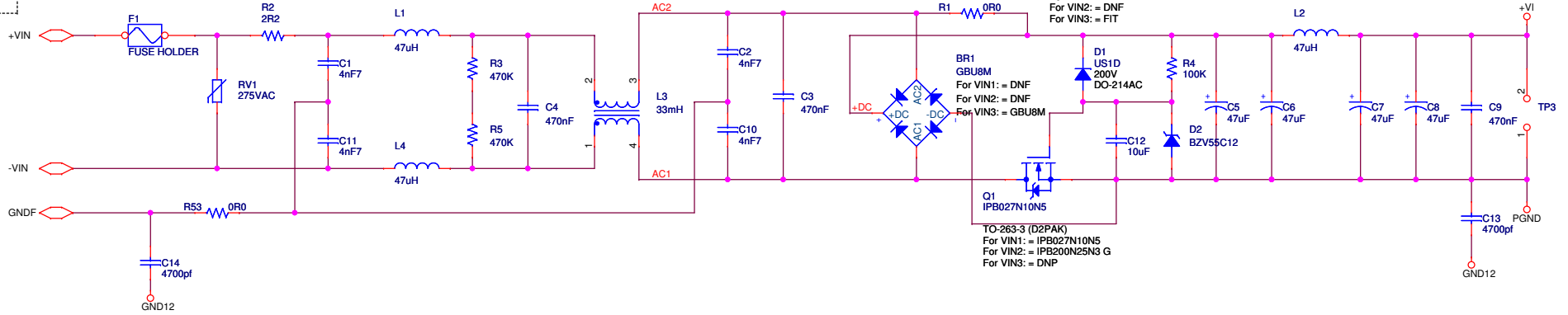

5

4

3

2

1

A

B

C

D