

VBAT

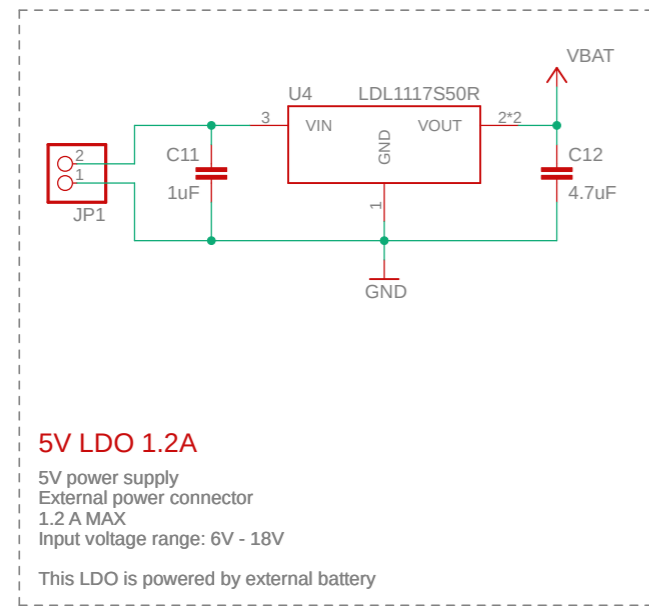

MUX

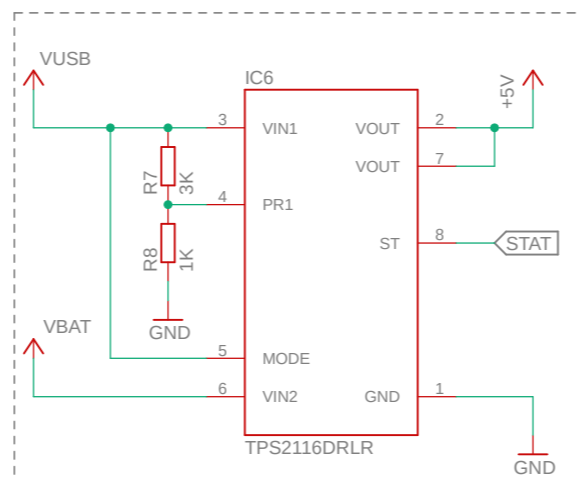

LED4 is ON when STAT is high
 It indicated that VOUT = VIN1
 IS IT A CORRECT DESIGN?

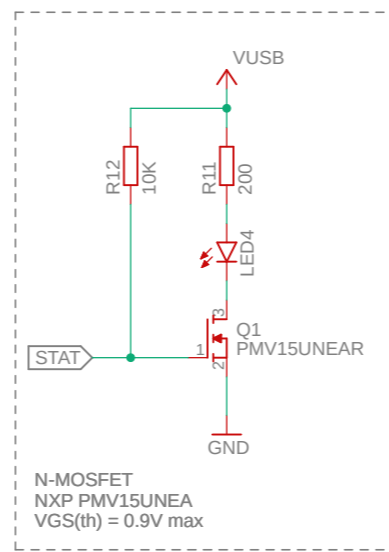

A 3V3

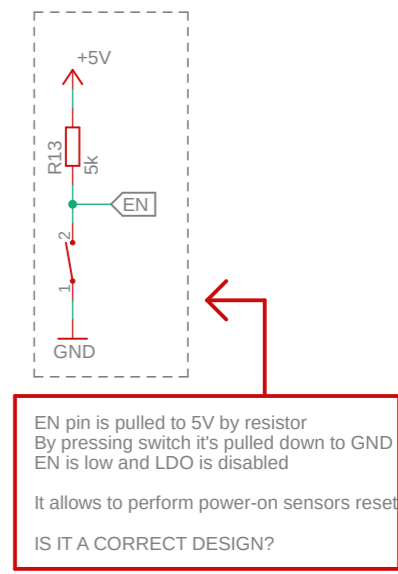
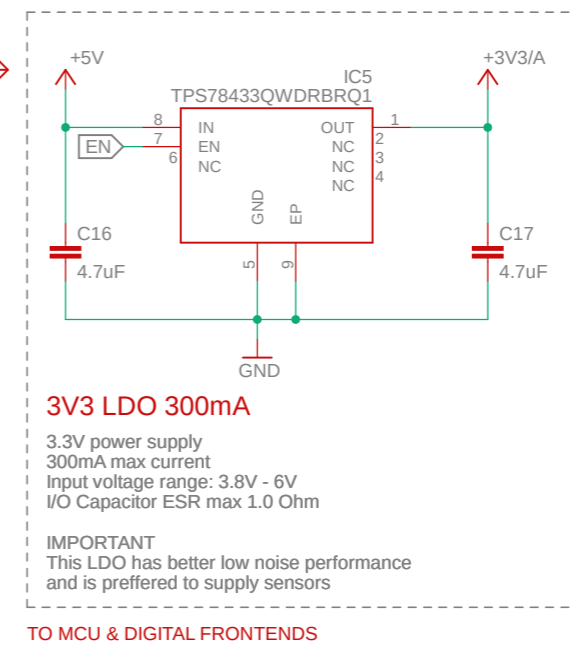

VUSB

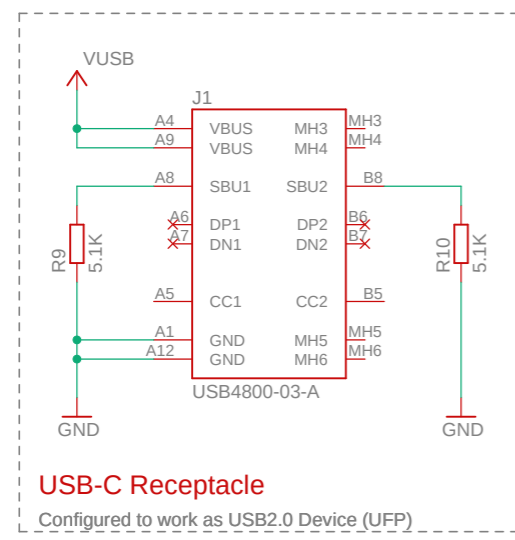

B 3V3

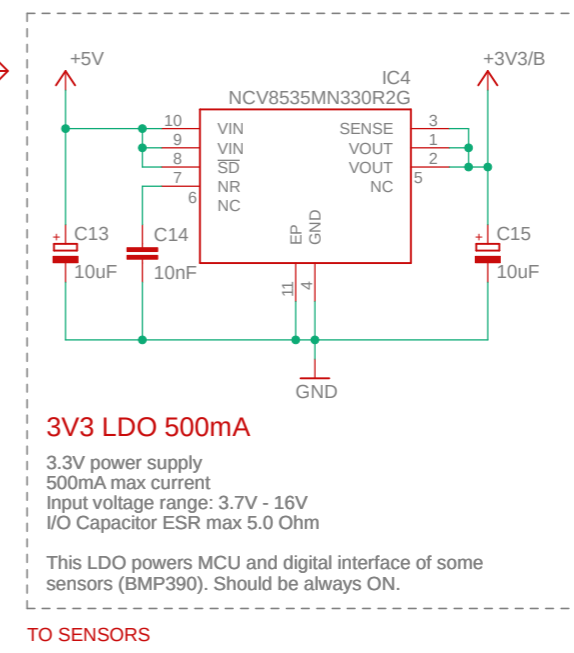

POWER SUBSYSTEM

Power supply	Michał Stomiany
Air Data Computer HAB V2	ADC_schematic
Rev A	07.01.2023 20:02
	Sheet: 2/3