

REVISION RECORD			
LTR	ECO NO:	APPROVED:	DATE:

BATTERY CONNECTOR

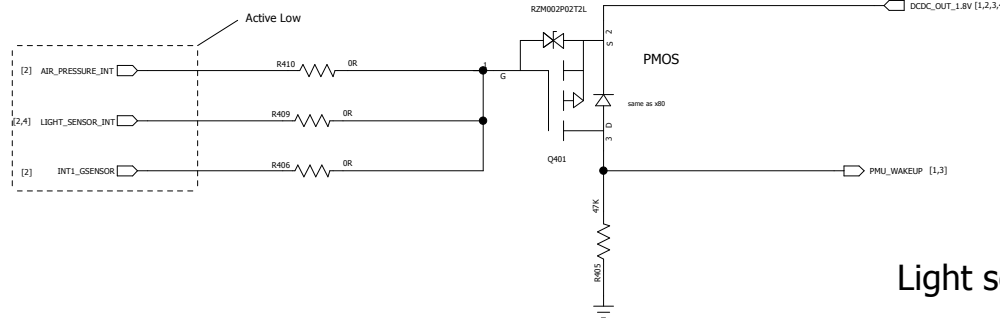

Light sensor

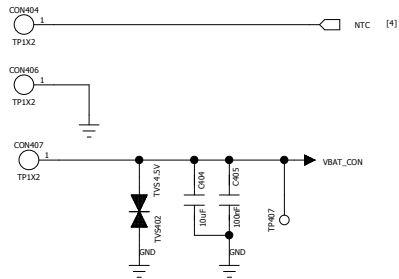
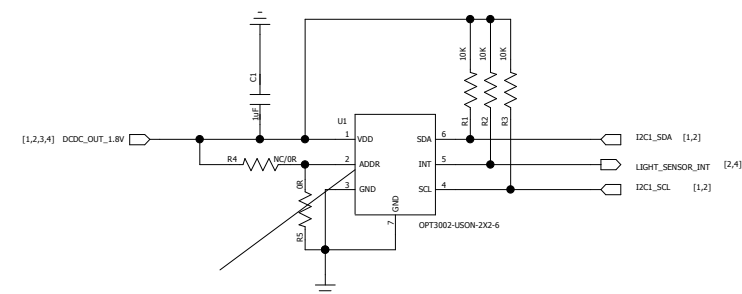

Charger interface

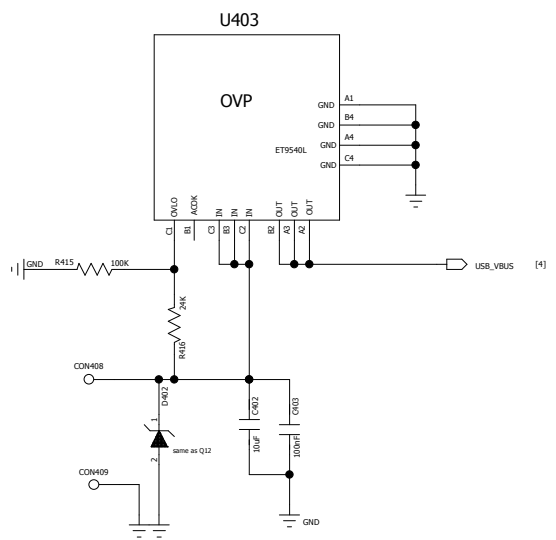

Charger

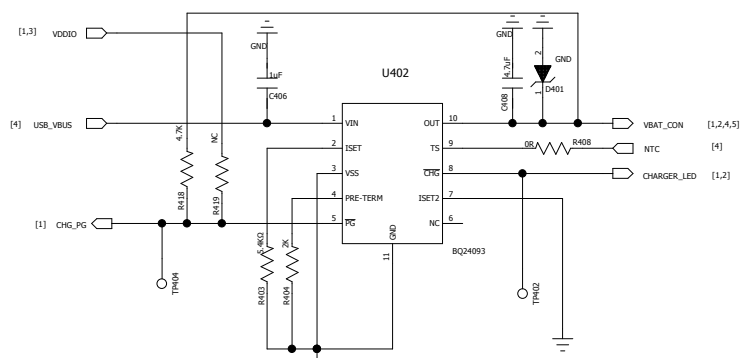

$R_{ISET} = [K(ISET) / I(OUT)]$
 $R_{ISET} = [540A? / 0.54A] = 1.0 K\Omega$

High = 500mAmax, Low = ISET, FLOAT = 100mA max.

COMPANY: HYMOST			
TITLE: A9			
CODE:	SIZE: A2	DRAWING NO: V1.02	REV: 190831
SCALE:	SHEET: 4		6

DRAWN:	DATED:
CHECKED:	DATED:
QUALITY CONTROL:	DATED:
RELEASED:	DATED: