

5V POWER SUPPLY

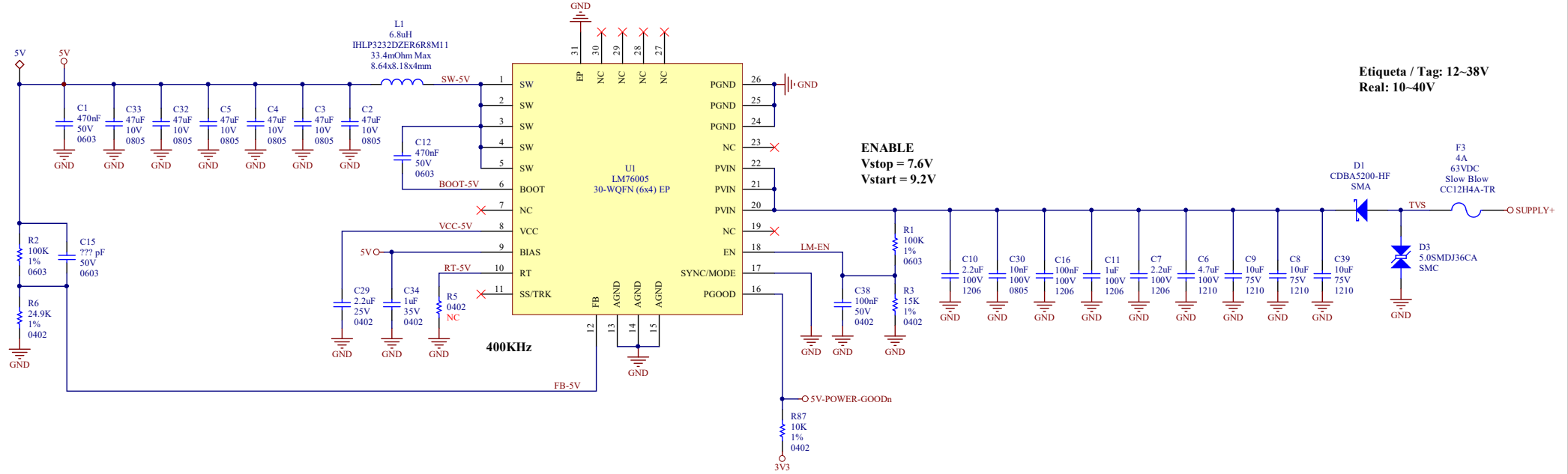

Etiqueta / Tag: 12-38V
Real: 10-40V

ENABLE
Vstop = 7.6V
Vstart = 9.2V

- Capacitor ceramic SMD, 10nF, +/-20%, 100V, 0805, X7R, Low ESL type. PN: CX0805MRX7R0BB103 (PulseLarsen) or 101X15W103MV4E (Johanson)
- Capacitor ceramic SMD, 100nF, +/-20%, 100V, 1206, X7R, Low ESL type. PN: 101X18W104MV4E (Johanson) or 101X18W104MV4 (Johanson)
- Capacitor ceramic SMD, 1uF, +/-10%, 100V, 1206, X7R or X5R, SMPS Filtering type. PN: HMK316B7105KL-T or HMK316BJ105KL-T (Taiyo Yuden)
- Capacitor ceramic SMD, 2.2uF, 100V, 1206, X5R or X7R, PN 12061C225KAT2A (Kyocera AVX) or CC1206KKX7R0BB225 (Yageo) or 12061C225MAT2A (Kyocera AVX) or HMK316ABJ225SML-TE (Taiyo Yuden) or HMK316ABJ225KL-TE (Taiyo Yuden)
- Capacitor ceramic SMD, 4.7uF, 100V, 1210, X5R or X7R. PN CL32B475KCVZW6E or HMK325BJ475KN-TE or HMK325BJ475KM-PE or HMK325BJ475MM-PE or HMK325BJ475MN-TE
- Capacitor ceramic SMD, 10uF, 75V, 1210, X7R or X5R, PN CGA6P1X7R1N106K250AC or CGA6P1X7R1N106M250AC or C3225X7R1N106K250AC, all these PNs are from TDK Corporation
- Capacitor ceramic SMD, 100nF, +/-10%, 50V, 0402, X7R or XR5, Low ESL type. PN: C1005X7R1H104K050BB (TDK) or C1005X5R1H104K050BB (TDK)
- Capacitor ceramic SMD, 470nF (0.47uF), 50V, 0603, X5R. PN CL10A474KB8NNNC (Samsung) or UMK107ABJ474KA-T (Taiyo Yuden)
- Capacitor ceramic SMD, 1uF, 35V, 0402, X5R. PN GMK105ABJ105KV-F or CL05A105KL5NRNC or C1005X5R1V105K050BC
- Capacitor ceramic SMD, 2.2uF, 25V, 0402, X5R. PN GRM155R61E225ME15D or C1005X5R1E225K050BC or TMK105CBJ225MV-F
- Capacitor ceramic SMD, 47uF, 10V, 0805, X5R, PN GRM21BR61A476ME15L (Murata)

Capacitor ceramic SMD, 10uF, 10V, 0402, X5R. PN CL05A106MP8NUB8 (Samsung)

GNSS ANTENNA CURRENT LIMITER 65-70mA

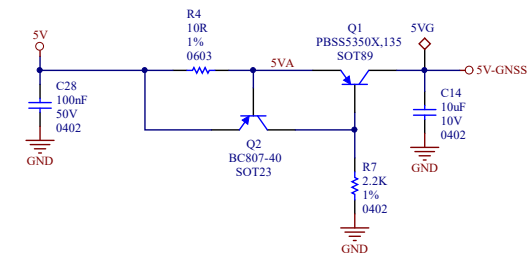

- ⊙ FURO-FIXACAO-1
- ⊙ FURO-FIXACAO-2
- ⊙ FURO-FIXACAO-3
- ⊙ FURO-FIXACAO-4

- FIDUCIAL1
- FIDUCIAL2
- FIDUCIAL3
- FIDUCIAL4

3.3V POWER SUPPLY

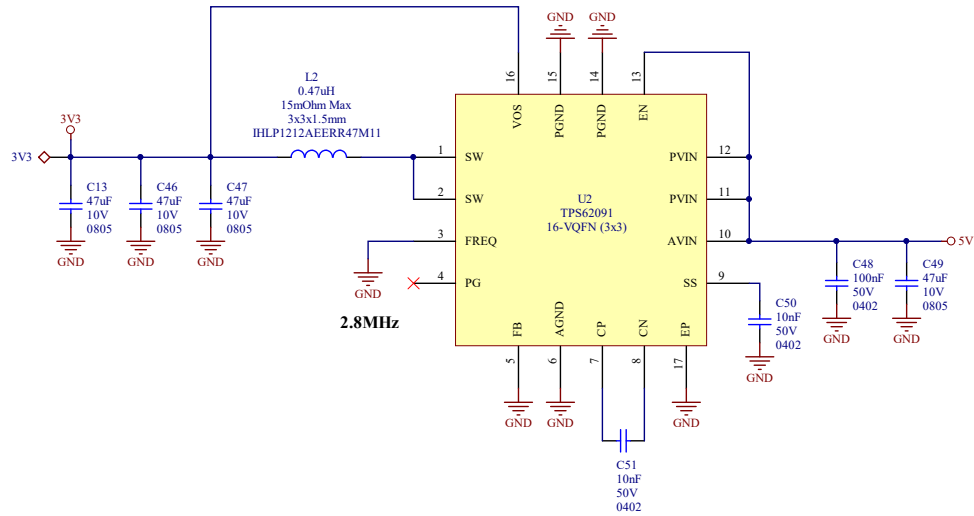

Capacitor ceramic SMD, 100nF, +10%, 50V, 0402, X7R or XR5, Low ESL type. PN: C1005X7R1H104K050BB (TDK) or C1005X5R1H104K050BB (TDK)

Capacitor ceramic SMD, 47uF, 10V, 0805, X5R, PN GRM21BR61A476ME15L (Murata)

CONNECTORS

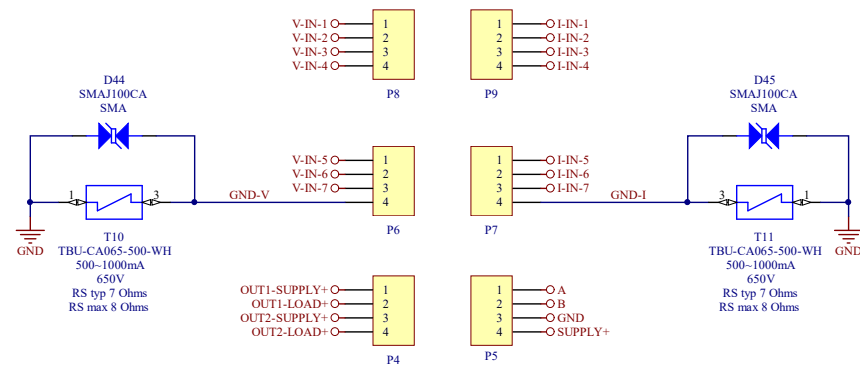

CONECTORES...

Título: PCB-SX			
SIRROS	Página: 2	Rev. da PCI: K	Rev. do Esquema: A
	Data:	Projetista: Jeferson Pehls	