

TPSM82822SIL_Design

1.Required specifications

Output Voltage					Output Current
min		typ	max		max
-2.500%	1.170V	1.200V	1.230V	2.500%	1.000A
-2.500%	1.170V	1.200V	1.230V	2.500%	100uA

The output voltage is used at the termination voltage of the FPGA (Xilinx UltraScale) gigabit transmitter.

2.Design output

The design results can be found in the following Documents.

- Schematic (Including Input / Oitput connection)
- BOM
- Cin & Cout Capacitor Data
- WEBENCH Export Data

I estimated the output accuracy as follows.

- DC accuracy
The detection consisted of a 0.1% resistor.
The accuracy is $\pm 1.101\%$
- Load Regulation
 $\pm 0.3\%$
- Line Regulation
 $\pm 0.3\%$
- Output Vp-p
 $\pm 5\text{mV} \rightarrow \pm 0.5\%$
- Total accuracy
 $\pm 2.2\%$

Is my output accuracy estimate correct?

Is the number of output capacitors "Cout" correct?

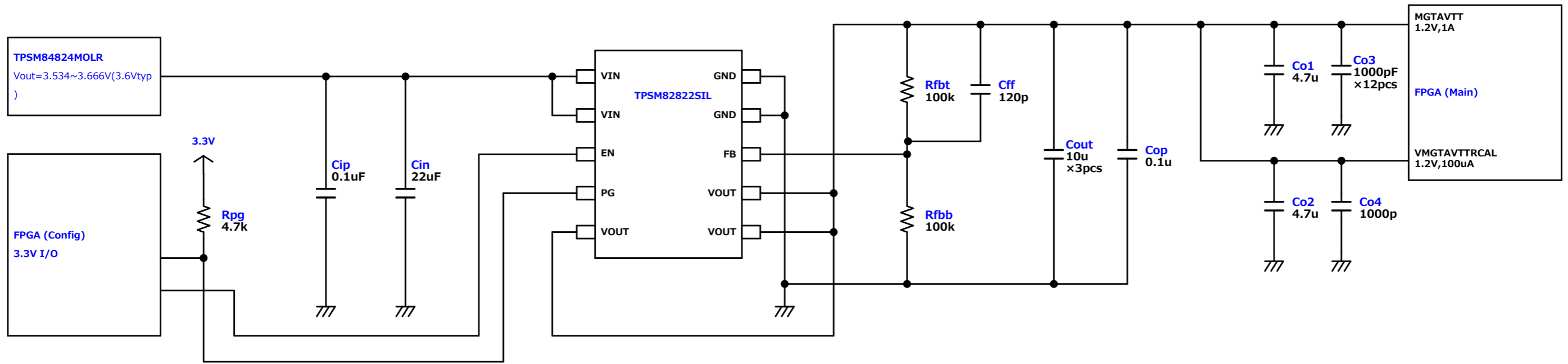

Part	Manufacturer	Part Number	Quantity	Description
Cout	MuRata	GRM188R61E106KA73D	3	Cap: 10.0 μ F Total Derated Cap: 27.9 μ F VDC: 25 V ESR: 3 m Ω Package: 0603
Cin	MuRata	GRM21BR61E226ME44L	1	Cap: 13.6 μ F Total Derated Cap: 13.6 μ F VDC: 25 V ESR: 2 m Ω Package: 0805
U1	Texas Instruments	TPSM82822SILR	1	
Rpg	KOA	RK73H1ETTP4701F	1	Resistance: 4.7 k Ω Tolerance: 1.0% Power: 100 mW Package: 0603
Cff	MuRata	GRM0335C1H121JA01D	1	Cap: 120 pF Total Derated Cap: 120 pF VDC: 25 V ESR: 90 m Ω Package: 0201
Rfbb	KOA	RN73R1ETTP1003B25	1	Resistance: 100 k Ω Tolerance: 0.1% Power: 63 mW Package: 0603
Rfbt	KOA	RN73R1ETTP1003B25	1	Resistance: 100 k Ω Tolerance: 0.1% Power: 63 mW Package: 0603
Cip	MuRata	GRM033R61E104KE14D	1	Cap: 0.1 uF Total Derated Cap: 0.077 uF VDC: 25 V ESR: 90 m Ω Package: 0201
Cop	MuRata	GRM033R61E104KE14D	1	Cap: 0.1 uF Total Derated Cap: 0.077 uF VDC: 25 V ESR: 90 m Ω Package: 0201
Co1	MuRata	GRM155C80J475MEAAD	1	Cap: 4.7 uF Total Derated Cap: 4.4 uF VDC: 6.3 V ESR: 9 m Ω Package: 0402
Co2	MuRata	GRM155C80J475MEAAD	1	Cap: 4.7 uF Total Derated Cap: 4.4 uF VDC: 6.3 V ESR: 9 m Ω Package: 0402
Co3	MuRata	GRM0335C1E102JA01D	12	Cap: 1000 pF Total Derated Cap: 1000 pF VDC: 25 V ESR: 10 m Ω Package: 0201
Co4	MuRata	GRM0335C1E102JA01D	1	Cap: 1000 pF Total Derated Cap: 1000 pF VDC: 25 V ESR: 10 m Ω Package: 0201

[Home](#) [Products](#) [Product Details](#)

[Capacitors](#) > [Ceramic Capacitors](#) > [Ceramic Capacitors\(SMD\)](#)

Chip Multilayer Ceramic Capacitors for General Purpose

Please be sure to read these general terms of use, before using this product.

[Cautions about imitations](#)

GRM21BR61E226ME44#

*# indicates a package specification code.

In Production ?



< List of part numbers with package codes >

GRM21BR61E226ME44L GRM21BR61E226ME44K

Appearance & Shape

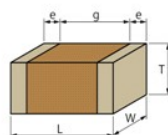

Specifications

[Search for products with similar specifications](#) ?

Length	2.0±0.2mm
Width	1.25±0.2mm
Thickness	1.25±0.2mm
Capacitance	22µF ±20%
Distance between external terminals g	0.7mm min.
External terminal size e	0.2 to 0.7mm
Operating Temperature Range	-55°C to 85°C
Rated Voltage	25Vdc
Size code in inch(mm)	0805 (2012M)
Capacitance change rate	±15.0%
Temperature characteristics (complied standard)	X5R(EIA)
Temperature range of temperature characteristics	-55°C to 85°C

Product Search Assistant

Introducing similar parts with same or smaller size.

- Smaller
- Higher capacitance (Nominal)
- Higher Voltage
- Higher Temperature
- Better DC bias
- Search silicon capacitors with similar capacitance

References

Packaging	Specifications	Minimum Order Quantity
L	180Embossed Tape	3000
K	330Embossed Tape	10000

Mass (typ.)	
1 piece	23.0mg
φ180mm Reel	118g

Characteristic Data

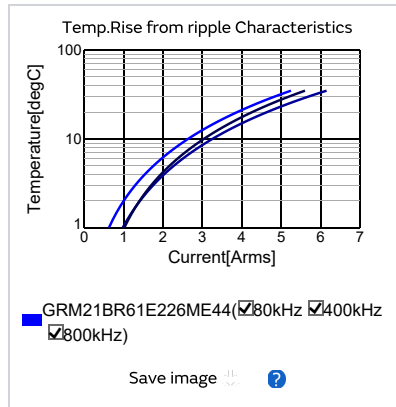
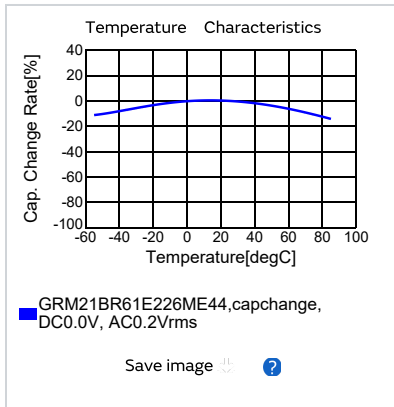
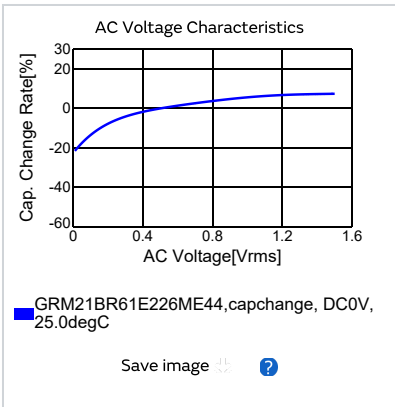
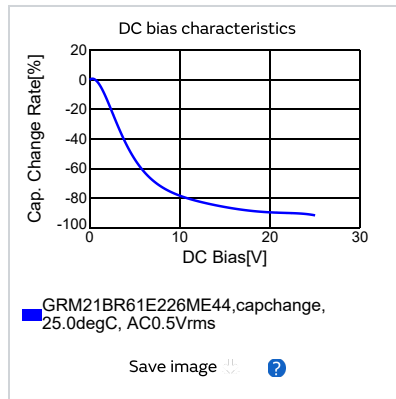
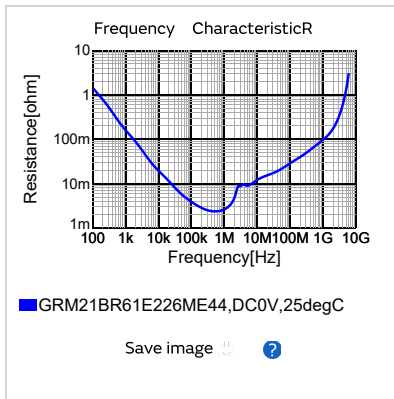
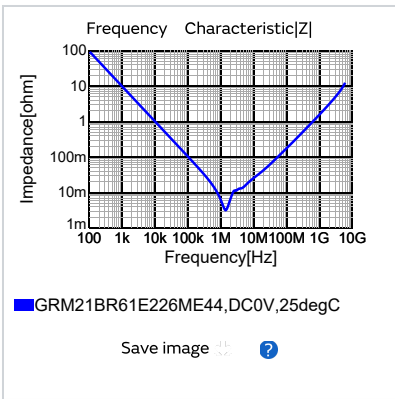

(Simsurfing)Go to the detailed chart [?](#)

[Home](#) [Products](#) [Product Details](#)

Capacitors > Ceramic Capacitors > Ceramic Capacitors(SMD)

Chip Multilayer Ceramic Capacitors for General Purpose

Please be sure to read these general terms of use, before using this product.

Cautions about imitations

GRM188R61E106KA73# *# indicates a package specification code.

In Production ?



< List of part numbers with package codes >

GRM188R61E106KA73J GRM188R61E106KA73D

Appearance & Shape

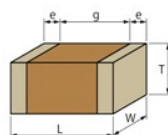

Specifications

[Search for products with similar specifications](#) ?

Length	1.6±0.2mm
Width	0.8±0.2mm
Thickness	0.8±0.2mm
Capacitance	10µF ±10%
Distance between external terminals g	0.6mm min.
External terminal size e	0.2 to 0.55mm
Operating Temperature Range	-55°C to 85°C
Rated Voltage	25Vdc
Size code in inch(mm)	0603 (1608M)
Capacitance change rate	±15.0%
Temperature characteristics (complied standard)	X5R(EIA)
Temperature range of temperature characteristics	-55°C to 85°C

Product Search Assistant

Introducing similar parts with same or smaller size.

- Smaller
- Higher capacitance (Nominal)
- Higher Voltage
- Higher Temperature
- Better DC bias
- Search silicon capacitors with similar capacitance

Notices

Measure capacitance after heat treatment

References

Packaging	Specifications	Minimum Order Quantity
J	330mm Paper Tape	10000
D	180mm Paper Tape	4000

Mass (typ.)	
1 piece	9.1mg
φ180mm Reel	166g

There is no characteristic data for "GRM188R61E106KA73", the same characteristic data "GRM188R61E106MA73" is shown.

Characteristic Data

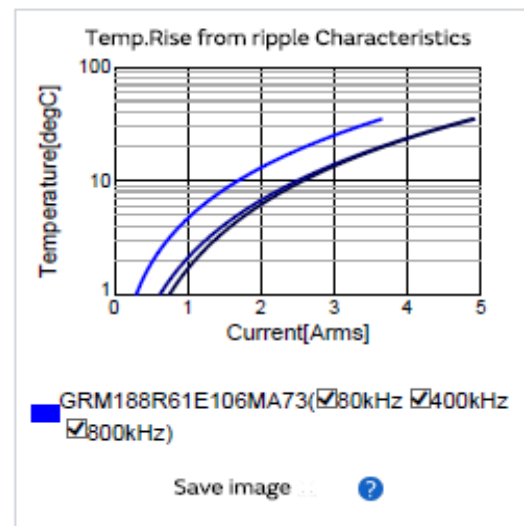
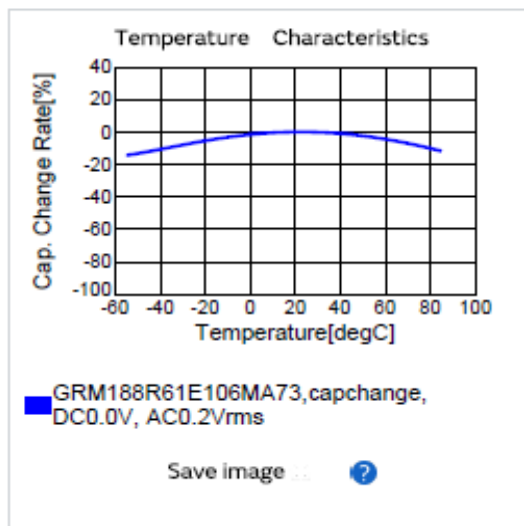
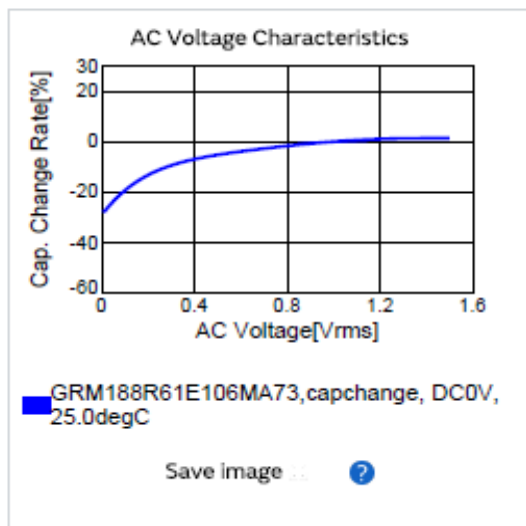
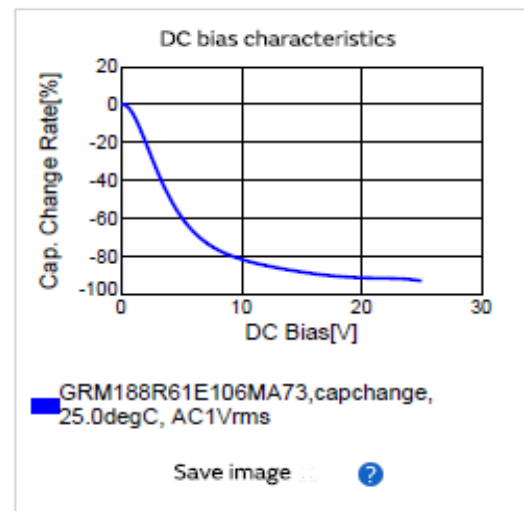
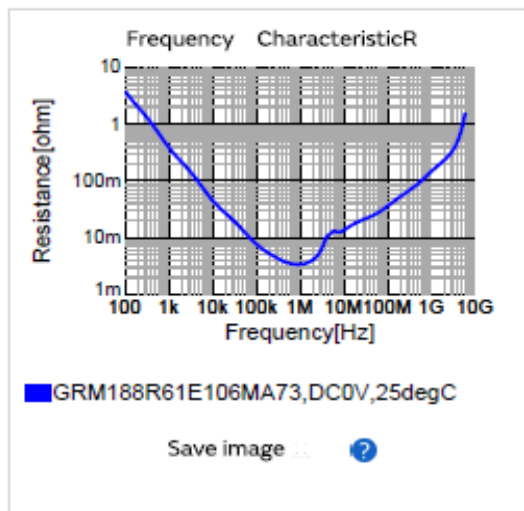
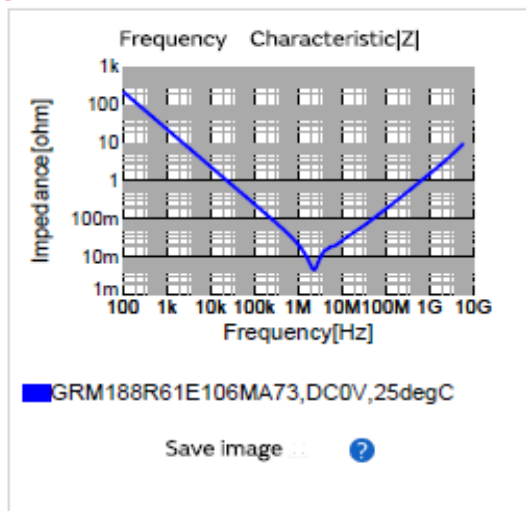

WEBENCH® Design Report

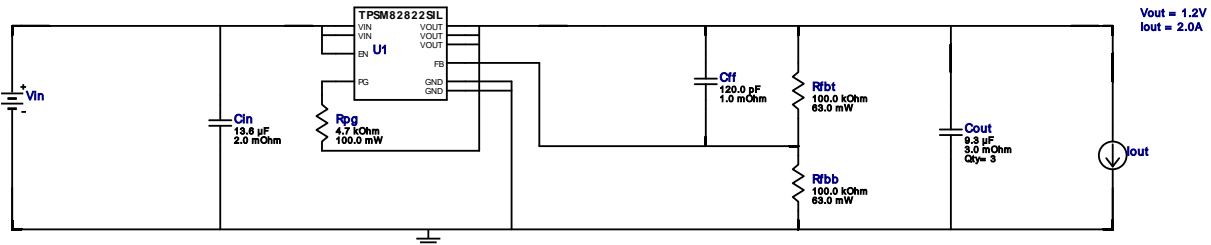
 Design : 56 TPSM82822SILR
 TPSM82822SILR 3.5V-3.7V to 1.20V @ 2A

Electrical BOM

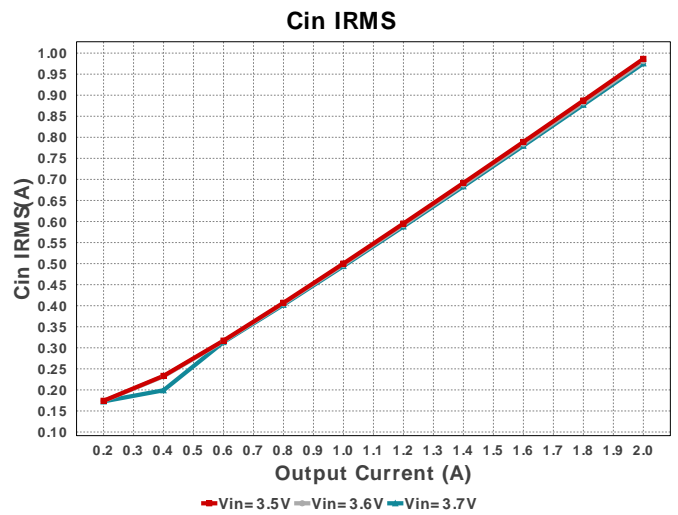
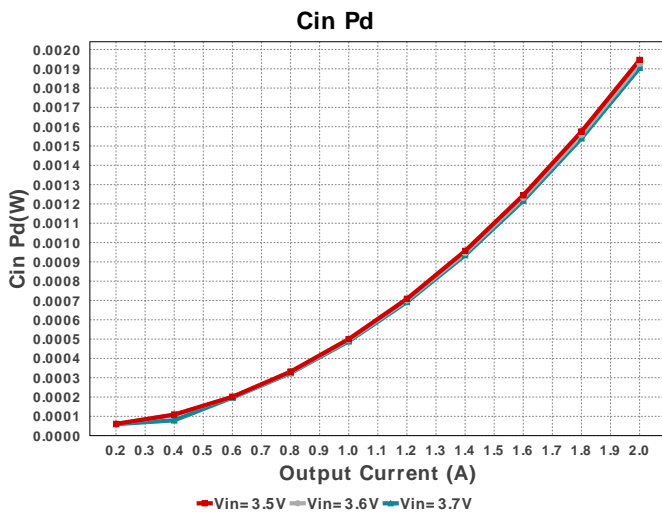
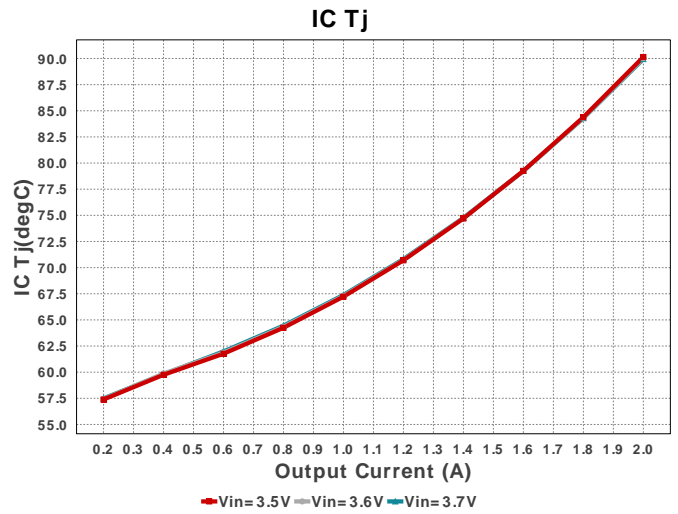
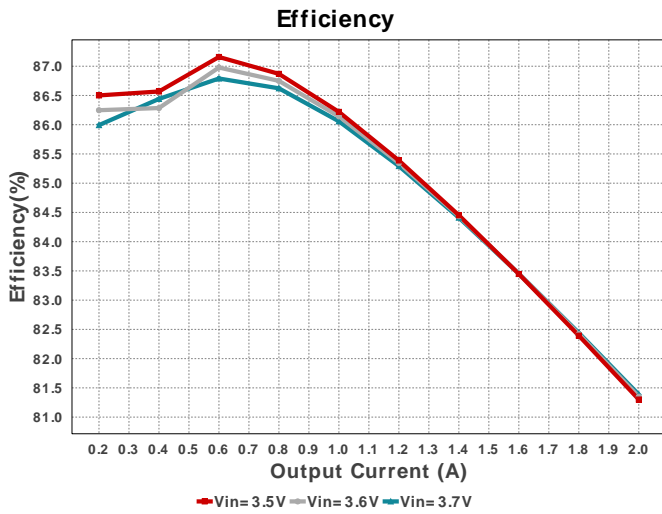
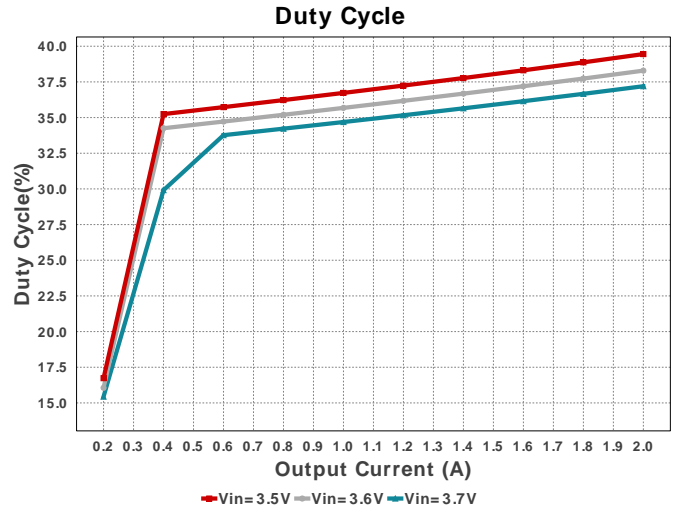
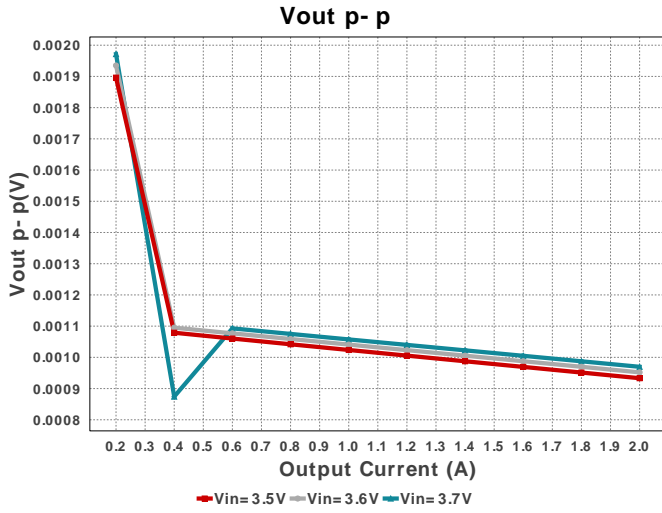
Name	Manufacturer	Part Number	Properties	Qty	Price	Footprint
Cff	MuRata	GRM0335C1H121JA01D Series= X7R	Cap= 120.0 pF ESR= 1.0 mOhm VDC= 25.0 V IRMS= 0.0 A	1	\$0.10	0201 2 mm ²
Cin	MuRata	GRM21BR61E226ME44L Series= X5R	Cap= 13.6 uF ESR= 2.0 mOhm VDC= 25.0 V IRMS= 2.8 A	1	\$0.10	0805 7 mm ²
Cout	MuRata	GRM188R61E106KA73D Series= X5R	Cap= 9.3 uF ESR= 3.0 mOhm VDC= 25.0 V IRMS= 2.4141 A	3	\$0.10	0603 5 mm ²
Rfbb	KOA	RN73R1ETTP1003B25 Series= CRCW...e3	Res= 100.0 kOhm Power= 63.0 mW Tolerance= 1.0%	1	\$0.10	0603 5 mm ²
Rfbb	KOA	RN73R1ETTP1003B25 Series= CRCW...e3	Res= 100.0 kOhm Power= 63.0 mW Tolerance= 1.0%	1	\$0.10	0603 5 mm ²
Rpg	KOA	RK73H1ETTP4701F Series= CRCW...e3	Res= 4.7 kOhm Power= 100.0 mW Tolerance= 1.0%	1	\$0.10	0402 3 mm ²
U1	Texas Instruments	TPSM82822SILR	Switcher	1	\$1.00	SIL0010D 10 mm ²

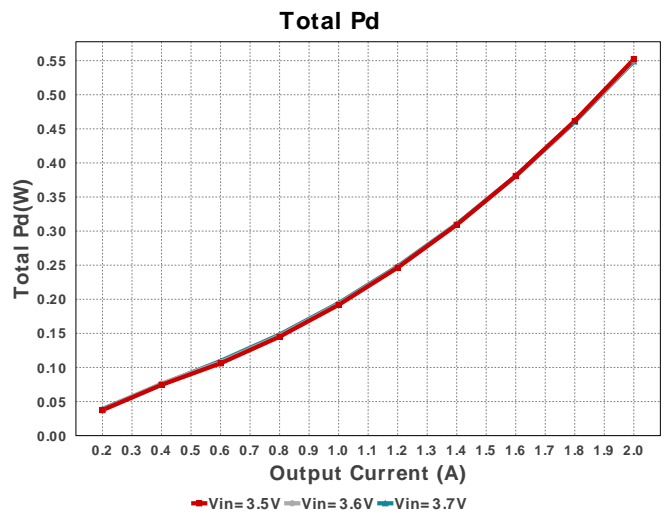
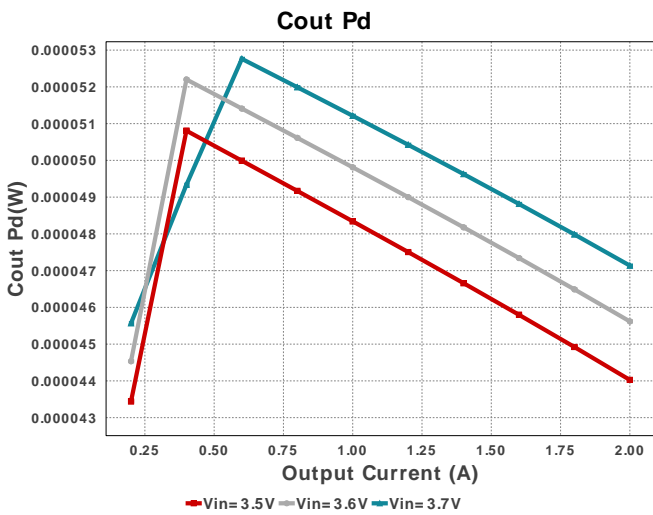
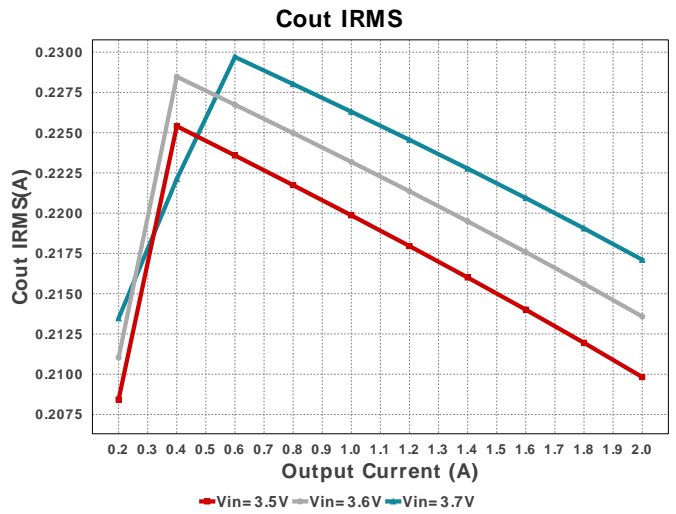
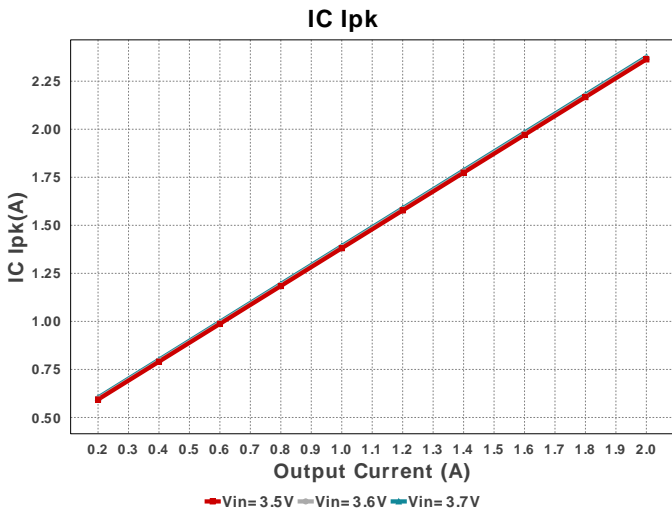
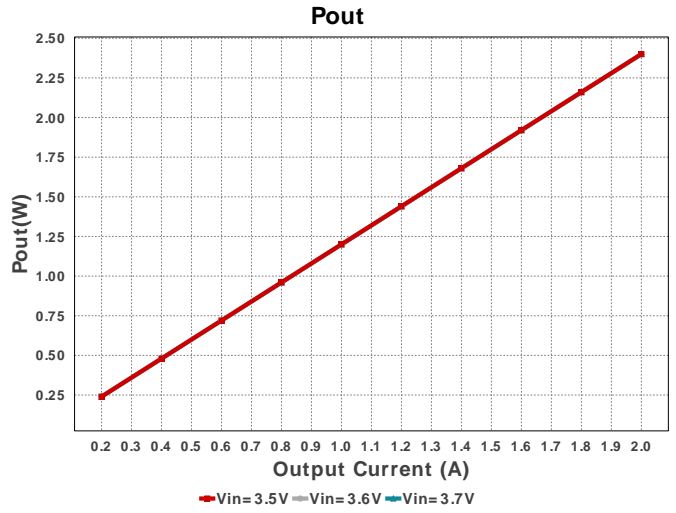
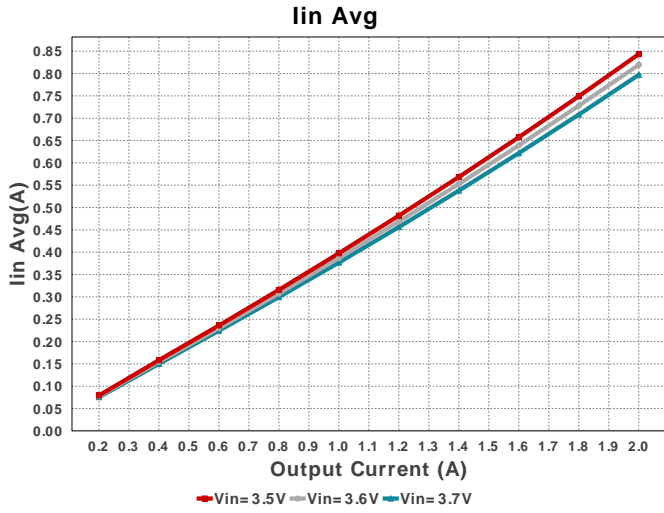

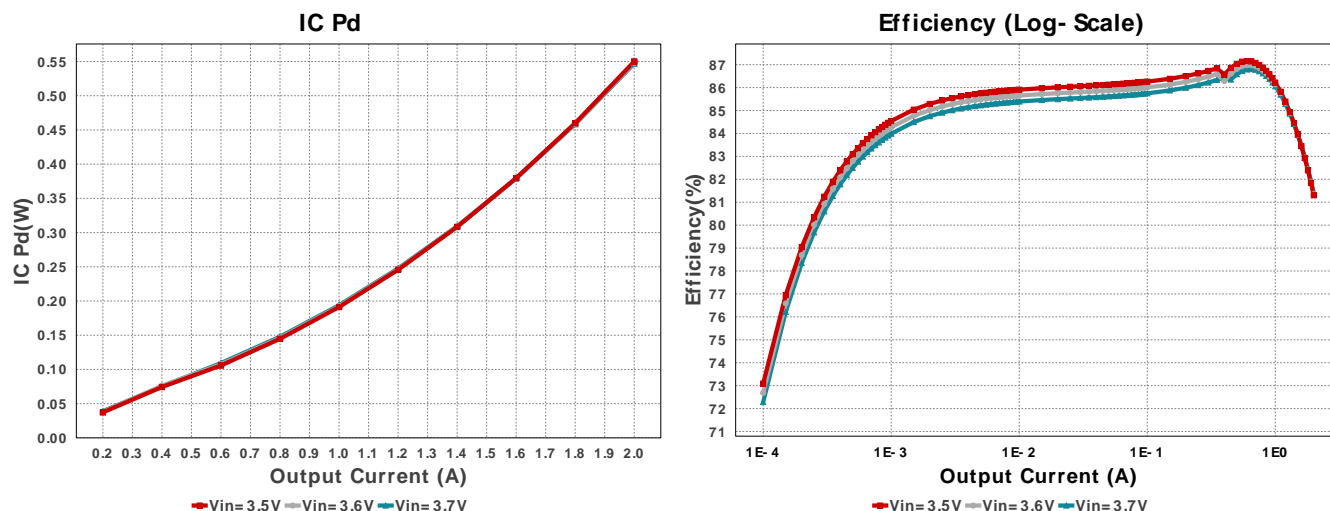



Operating Values

#	Name	Value	Category	Description
1.	BOM Count	9		Total Design BOM count
2.	Total BOM	\$1.8		Total BOM Cost
3.	Cin IRMS	975.688 mA	Capacitor	Input capacitor RMS ripple current
4.	Cin Pd	1.904 mW	Capacitor	Input capacitor power dissipation
5.	Cout IRMS	217.11 mA	Capacitor	Output capacitor RMS ripple current
6.	Cout Pd	47.137 μ W	Capacitor	Output capacitor power dissipation
7.	IC Ipk	2.376 A	IC	Peak switch current in IC
8.	IC Pd	546.94 mW	IC	IC power dissipation
9.	IC Tj	89.949 degC	IC	IC junction temperature
10.	ICThetaJA Effective	63.9 degC/W	IC	Effective IC Junction-to-Ambient Thermal Resistance
11.	Iin Avg	797.0 mA	IC	Average input current
12.	Cin Pd	1.904 mW	Power	Input capacitor power dissipation
13.	Cout Pd	47.137 μ W	Power	Output capacitor power dissipation
14.	IC Pd	546.94 mW	Power	IC power dissipation
15.	Total Pd	548.908 mW	Power	Total Power Dissipation
16.	Duty Cycle	37.197 %	System	Duty cycle
17.	Efficiency	81.386 %	System	Steady state efficiency
18.	FootPrint	46.0 mm ²	System	Total Foot Print Area of BOM components
19.	Frequency	4.352 MHz	System	Switching frequency
20.	Iout	2.0 A	System	Iout operating point
21.	Mode	CCM	System	Conduction Mode
22.	Pout	2.4 W	System	Total output power
23.	Vin	3.7 V	System	Vin operating point
24.	Vout	1.2 V	System	Operational Output Voltage
25.	Vout Actual	1.2 V	System	Vout Actual calculated based on selected voltage divider resistors
26.	Vout Tolerance	2.02 %	System	Vout Tolerance based on IC Tolerance (no load) and voltage divider resistors if applicable
27.	Vout p-p	969.723 μ V	System	Peak-to-peak output ripple voltage

Design Inputs

Name	Value	Description
Iout	2.0	Maximum Output Current
VinMax	3.7	Maximum input voltage
VinMin	3.5	Minimum input voltage
Vout	1.2	Output Voltage
base_pn	TPSM82822	Base Product Number
source	DC	Input Source Type
Ta	55.0	Ambient temperature

WEBENCH® Assembly

Component Testing

Some published data on components in datasheets such as Capacitor ESR and Inductor DC resistance is based on conservative values that will guarantee that the components always exceed the specification. For design purposes it is usually better to work with typical values. Since this data is not always available it is a good practice to measure the Capacitance and ESR values of C_{in} and C_{out} , and the inductance and DC resistance of $L1$ before assembly of the board. Any large discrepancies in values should be electrically simulated in WEBENCH to check for instabilities and thermally simulated in WebTHERM to make sure critical temperatures are not exceeded.

Soldering Component to Board

If board assembly is done in house it is best to tack down one terminal of a component on the board then solder the other terminal. For surface mount parts with large tabs, such as the DPAK, the tab on the back of the package should be pre-tinned with solder, then tacked into place by one of the pins. To solder the tab down to the board place the iron down on the board while resting against the tab, heating both surfaces simultaneously. Apply light pressure to the top of the plastic case until the solder flows around the part and the part is flush with the PCB. If the solder is not flowing around the board you may need a higher wattage iron (generally 25W to 30W is enough).

Initial Startup of Circuit

It is best to initially power up the board by setting the input supply voltage to the lowest operating input voltage 3.5V and set the input supply's current limit to zero. With the input supply off connect up the input supply to V_{in} and GND. Connect a digital volt meter and a load if needed to set the minimum load of the design from V_{out} and GND. Turn on the input supply and slowly turn up the current limit on the input supply. If the voltage starts to rise on the input supply continue increasing the input supply current limit while watching the output voltage. If the current increases on the input supply, but the voltage remains near zero, then there may be a short or a component misplaced on the board. Power down the board and visually inspect for solder bridges and recheck the diode and capacitor polarities. Once the power supply circuit is operational then more extensive testing may include full load testing, transient load and line tests to compare with simulation results.

Load Testing

The setup is the same as the initial startup, except that an additional digital voltmeter is connected between V_{in} and GND, a load is connected between V_{out} and GND and a current meter is connected in series between V_{out} and the load. The load must be able to handle at least rated output power + 50% (7.5 watts for this design). Ideally the load is supplied in the form of a variable load test unit. It can also be done in the form of suitably large power resistors. When using an oscilloscope to measure waveforms on the prototype board, the ground leads of the oscilloscope probes should be as short as possible and the area of the loop formed by the ground lead should be kept to a minimum. This will help reduce ground lead inductance and eliminate EMI noise that is not actually present in the circuit.

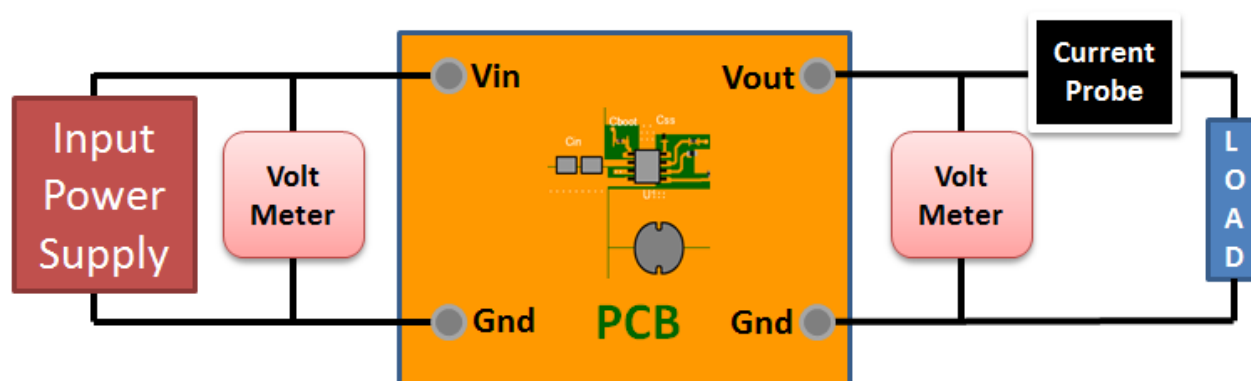

Design Assistance

1. Master key : 4B22EECAC03607DD[v1]
2. **TPSM82822** Product Folder : <http://www.ti.com/product/TPSM82822> : contains the data sheet and other resources.

Important Notice and Disclaimer

TI provides technical and reliability data (including datasheets), design resources (including reference designs), application or other design advice, web tools, safety information, and other resources AS IS and with all faults, and disclaims all warranties. These resources are intended for skilled developers designing with TI products. You are solely responsible for (1) selecting the appropriate TI products for your application, (2) designing, validating and testing your application, and (3) ensuring your application meets applicable standards, and any other safety, security, or other requirements.

These resources are subject to change without notice. TI grants you permission to use these resources only for development of an application that uses the TI products described in the resource. Other reproduction and display of these resources is prohibited. No license is granted to any other TI intellectual property right or to any third party intellectual property right. TI disclaims responsibility for, and you will fully indemnify TI and its representatives against, any claims, damages, costs, losses, and liabilities arising out of your use of these resources.

Providing these resources does not expand or otherwise alter TI's applicable Terms of Sale or other applicable terms available either on ti.com or provided in conjunction with TI products.