

PWR : V3P3_A/V5_A VR

MODULE REV DETAILS

MODULE NAME	REV	DATE

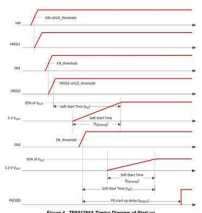
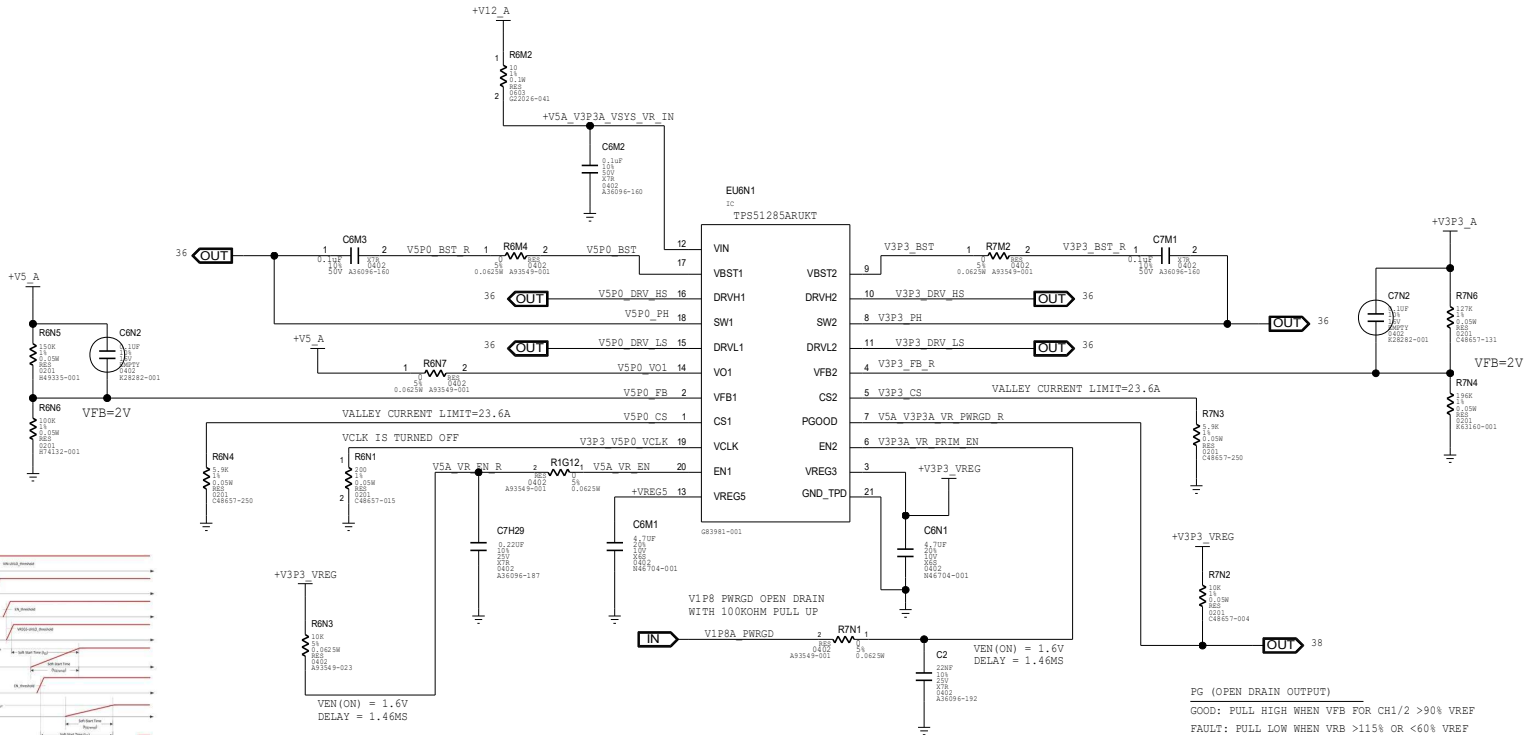

Figure 4. TPS51285A Timing Diagram of Enable

PG (OPEN DRAIN OUTPUT)
 GOOD: PULL HIGH WHEN VFB FOR CH1/2 >90% VREF
 FAULT: PULL LOW WHEN VRB >115% OR <60% VREF

