

Safe Startup of Brushless DC Fan with TPS2592A eFuse

Dinesh Kumar

ABSTRACT

This application note describes the problem of an inrush current of the DC brushless fan during start up, and explains how this undesirable huge inrush current is lowered to be within the acceptable limits by using TI's TPS2592A e-Fuse. Bringing inrush current within safe limits helps the designer to achieve a low-cost solution.

Brushless DC fans have been an effective and easy method of cooling power electronic circuits. Brushless DC fans having the advantage of small size and high reliability are used extensively in many new applications. Because the speed and airflow of a typical DC fan is proportional to the voltage supplied, a single product can be used to meet the different applications by setting the supply voltage to provide the desired airflow. Brushless DC fans do not draw constant DC currents even under a steady state condition.

When designing the electronics that interface to a DC brushless cooling fan, it is critically important to be aware that brushless cooling fans draw substantially higher inrush current than steady state running current. The choice of the input power source and energy storage to support the inrush current drawn is affected by the type of DC fans and its motor current characteristics. To meet the large inrush current, demand of the cooling fan designer is generally left with choices such as using the oversized DC power supply which does not cause the voltage drop while the fan draws the inrush current, and selecting a driver that can safely handle the large inrush current or installing adequate current limiting – which is not the desired solution from a system cost and reliability view point.

Contents

1	Steady-State and Inrush Current Drawn by the Fan	2
2	Cooling Fan Inrush Current Control by Using TPS2592A	5
3	Conclusion	6

List of Figures

1	Direct Connection of Brushless DC Fan with 12-VDC Power Supply	2
2	Start-Up Inrush Current of Brushless Fan (AF0612DE)	2
3	Zoomed Inrush Current Waveform Shows > 5.5-A Peak Current	3
4	5 Fan Start-up to Steady-state Operation When Directly Driven with a 12-V Source.....	3
5	Steady-state Current Waveform Brushless Fan (AF0612DE)	4
6	Typical Circuit Diagram with TPS2592A for Safe Start-Up of Fan	5
7	Fan Input Voltage and Startup Current with TPS2592A	5
8	Steady-state Fan Current Waveform with TPS2592A	6
9	Fan Start-up to Steady-state Operation with TPS2592A	6

1 Steady-State and Inrush Current Drawn by the Fan

A brushless DC fan (Delta Model–AF0612DE) is considered for this experiment. The fan is rated for 1.8 A at 12 V, but when this is directly connected (Figure 1) with a 12-V DC power source, the fan draws huge inrush as shown in Figure 2.

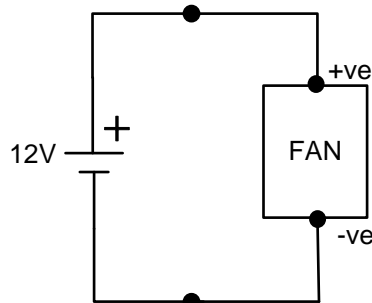

Figure 1. Direct Connection of Brushless DC Fan with 12-VDC Power Supply

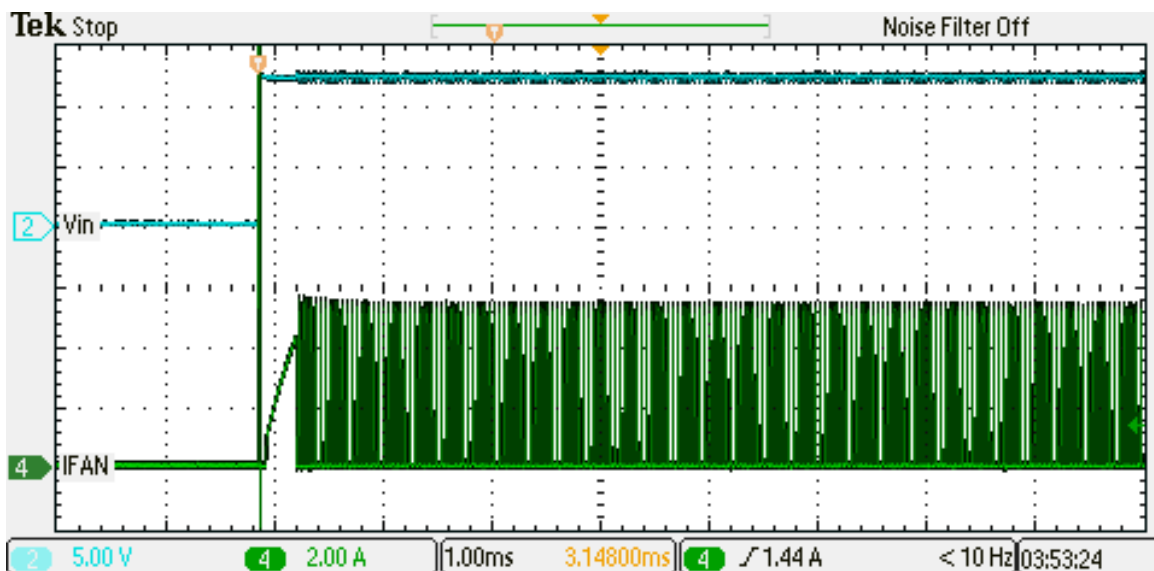

Figure 2. Start-Up Inrush Current of Brushless Fan (AF0612DE)

The zoomed version of Figure 2 is shown in Figure 3, which shows the peak current value drawn during start-up time. It is clear from these waveforms that inrush current is much higher (> 5.5 A) than the average-run current (1.8 A). Actually, the ratio of inrush to average-run current is 3.

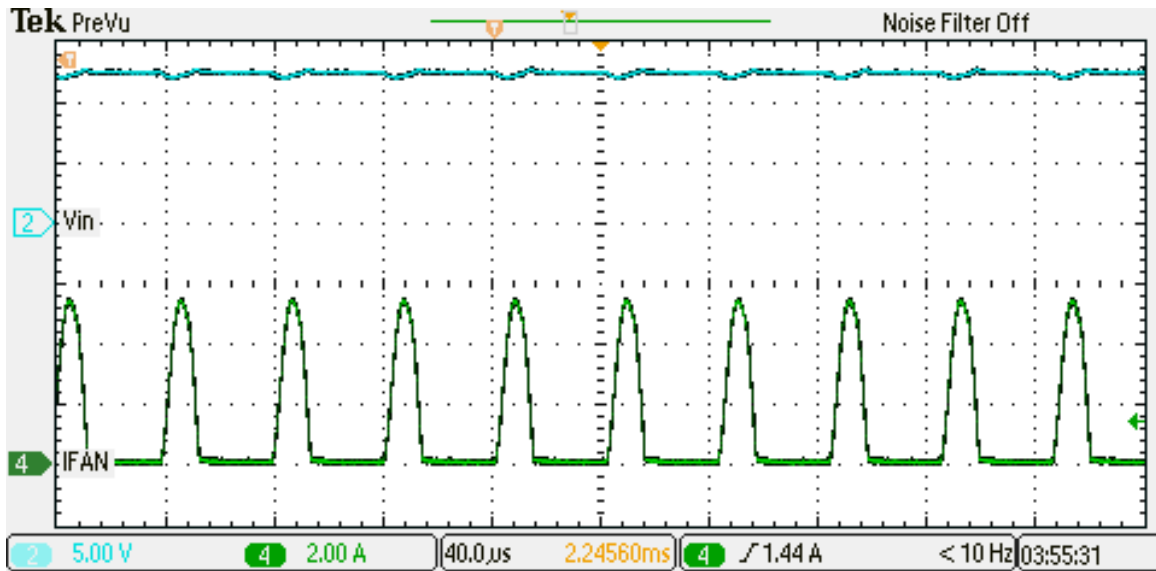

Figure 3. Zoomed Inrush Current Waveform Shows > 5.5-A Peak Current

Also, start-up to steady state operation of the fan is shown in Figure 4. This shows that it takes approximately 750 ms before the fan reaches its final speed, and the fan current comes to the final settling value.

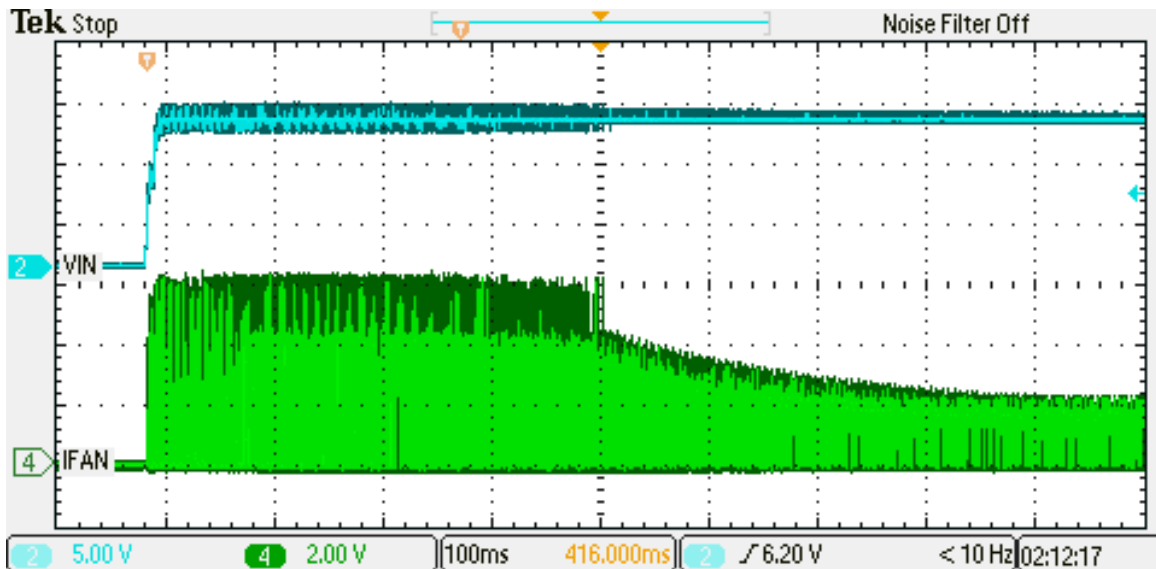

Figure 4. Fan Start-up to Steady-state Operation When Directly Driven with a 12-V Source

Figure 4 also shows that the fan continues to draw more than 5-A peak current until 400 ms. These times and current limits are compared later in this document when the fan is operated with the safe start-up technique.

When the fan attains full speed, its current comes down to the steady-state value and its waveform is shown in [Figure 5](#).

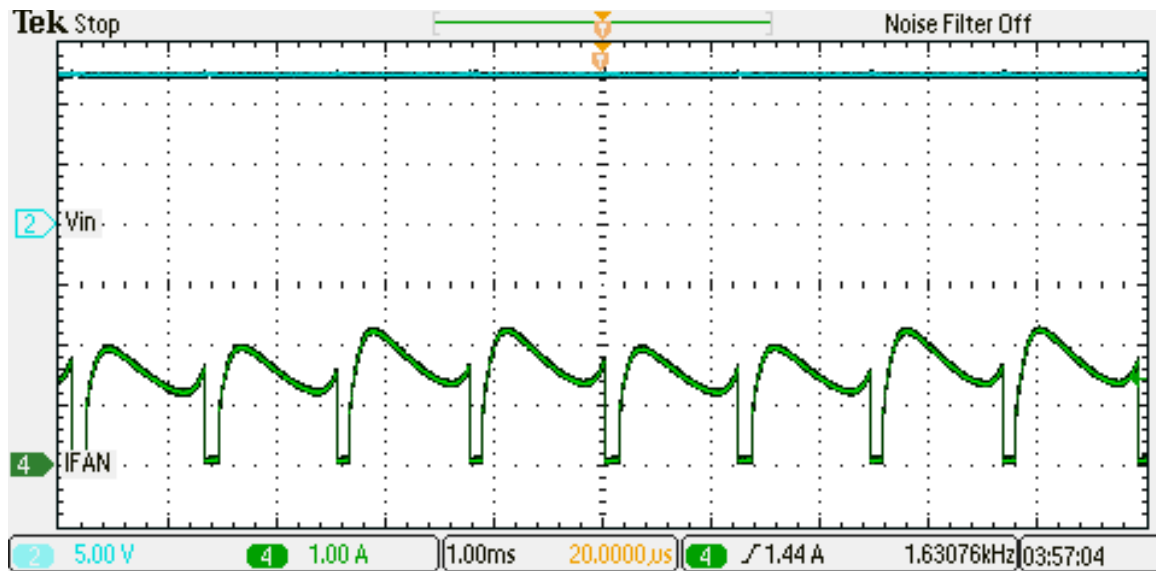

Figure 5. Steady-state Current Waveform Brushless Fan (AF0612DE)

High inrush current comes with some system-level disadvantages:

- Expensive, high-current rated connectors are needed to support huge start up.
- The PCB traces can burn or get weaker over time.
- May require a larger input capacitor to feed inrush demand, if the input DC source is not capable of meeting the demand.

2 Cooling Fan Inrush Current Control by Using TPS2592A

All disadvantages and issues (previously discussed) caused by the higher start-up inrush current of the fan are addressed by using the simple and low-part-count application circuit shown in Figure 6, which is used between the 12-V input supply and the fan to be controlled. TI's TPS2592A is used here to control the inrush current flow into the cooling fan. The resistor R_{ILIM} sets the limit on the maximum current allowed from input to output. In this case, the current limit is set to 2.5 A.

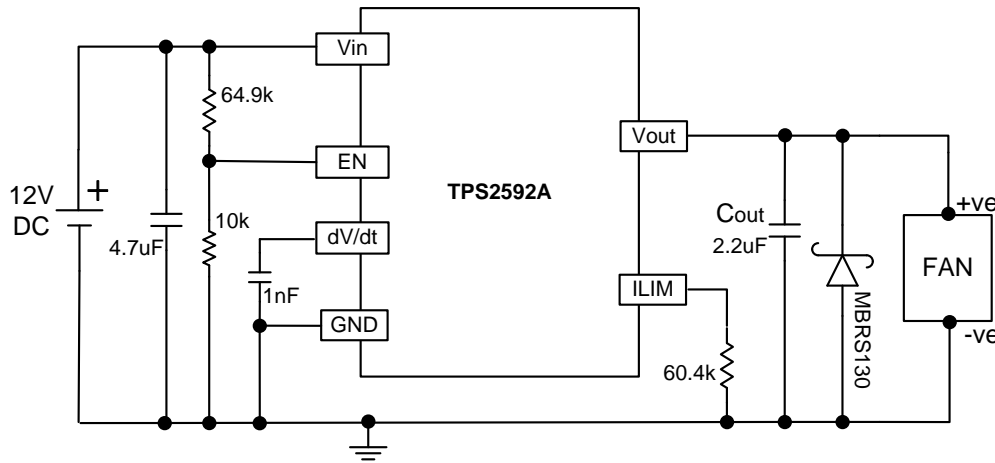

Figure 6. Typical Circuit Diagram with TPS2592A for Safe Start-Up of Fan

When the fan was ran through TPS2592A, the input voltage and fan current behavior is depicted in Figure 7. This shows that the TPS2592A controls the inrush current to nearly steady-state running current without drawing any unwanted current peak.

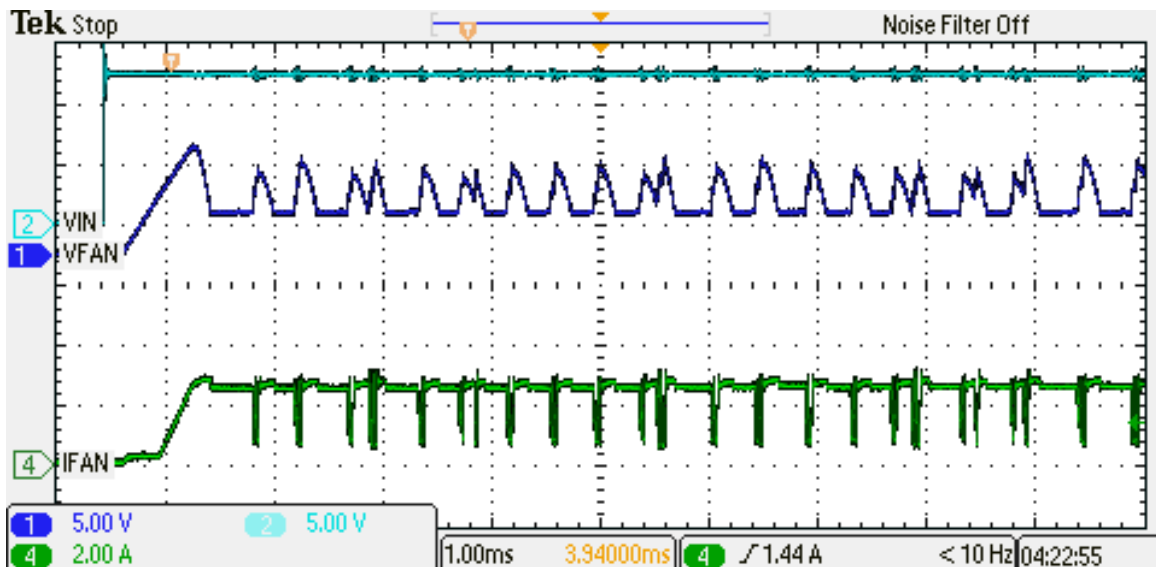

Figure 7. Fan Input Voltage and Startup Current with TPS2592A

Figure 8 shows the steady-state fan current waveform when it is driven through the TPS2592A. This shows that the TPS2592A does not impact the fan performance under normal operation.

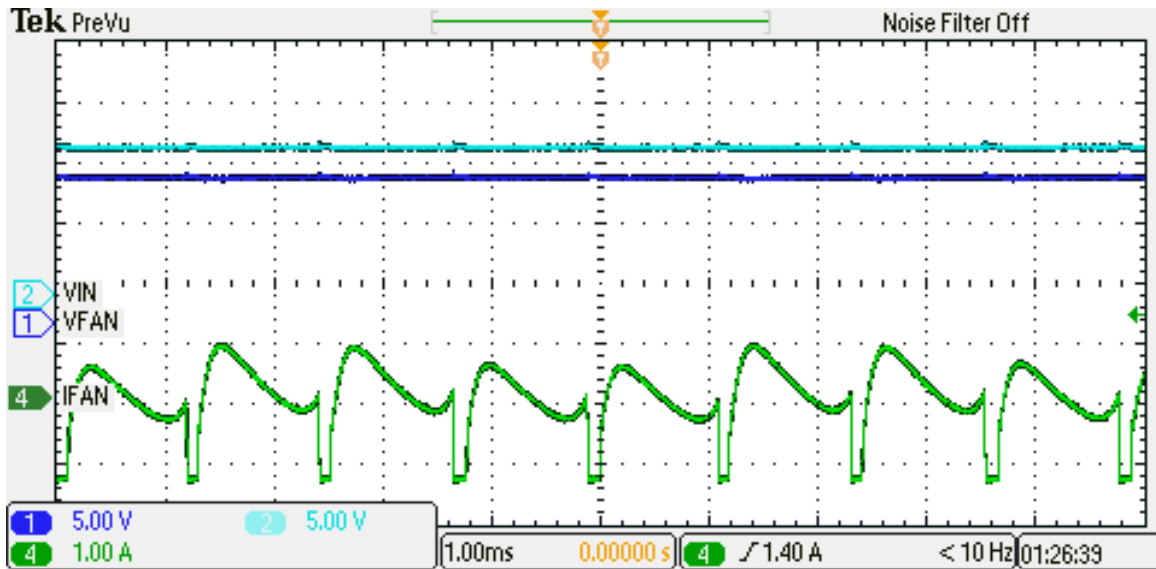

Figure 8. Steady-state Fan Current Waveform with TPS2592A

Again start-up to steady-state operation is shown in Figure 9 when the fan is driven through the TPS2592A. Since the fan start-up current is limited to 2.5 A, the time fan takes to achieve the final speed and settling current is larger (≈ 1200 ms) as expected.

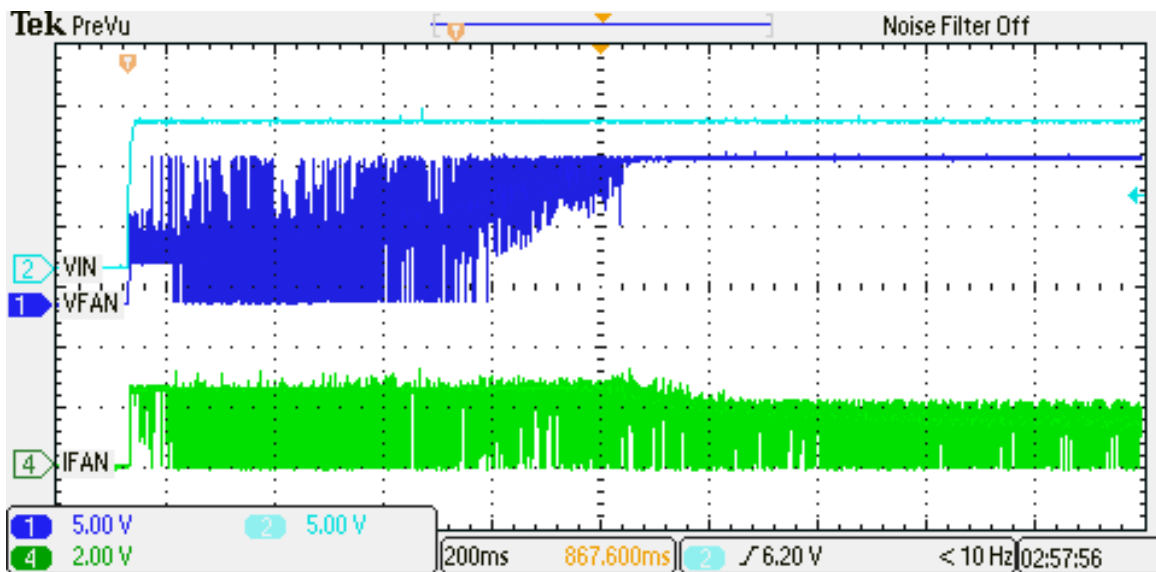

Figure 9. Fan Start-up to Steady-state Operation with TPS2592A

3 Conclusion

When the TPS2592A e-fuse is used with cooling fan or even larger fans such as in server application, it avoids the large inrush current and enables safe start-up of the fans, without getting an input power source trip or shutdown. This helps reduce the on board connector cost and increase the life of PCB traces.

IMPORTANT NOTICE

Texas Instruments Incorporated and its subsidiaries (TI) reserve the right to make corrections, enhancements, improvements and other changes to its semiconductor products and services per JESD46, latest issue, and to discontinue any product or service per JESD48, latest issue. Buyers should obtain the latest relevant information before placing orders and should verify that such information is current and complete. All semiconductor products (also referred to herein as "components") are sold subject to TI's terms and conditions of sale supplied at the time of order acknowledgment.

TI warrants performance of its components to the specifications applicable at the time of sale, in accordance with the warranty in TI's terms and conditions of sale of semiconductor products. Testing and other quality control techniques are used to the extent TI deems necessary to support this warranty. Except where mandated by applicable law, testing of all parameters of each component is not necessarily performed.

TI assumes no liability for applications assistance or the design of Buyers' products. Buyers are responsible for their products and applications using TI components. To minimize the risks associated with Buyers' products and applications, Buyers should provide adequate design and operating safeguards.

TI does not warrant or represent that any license, either express or implied, is granted under any patent right, copyright, mask work right, or other intellectual property right relating to any combination, machine, or process in which TI components or services are used. Information published by TI regarding third-party products or services does not constitute a license to use such products or services or a warranty or endorsement thereof. Use of such information may require a license from a third party under the patents or other intellectual property of the third party, or a license from TI under the patents or other intellectual property of TI.

Reproduction of significant portions of TI information in TI data books or data sheets is permissible only if reproduction is without alteration and is accompanied by all associated warranties, conditions, limitations, and notices. TI is not responsible or liable for such altered documentation. Information of third parties may be subject to additional restrictions.

Resale of TI components or services with statements different from or beyond the parameters stated by TI for that component or service voids all express and any implied warranties for the associated TI component or service and is an unfair and deceptive business practice. TI is not responsible or liable for any such statements.

Buyer acknowledges and agrees that it is solely responsible for compliance with all legal, regulatory and safety-related requirements concerning its products, and any use of TI components in its applications, notwithstanding any applications-related information or support that may be provided by TI. Buyer represents and agrees that it has all the necessary expertise to create and implement safeguards which anticipate dangerous consequences of failures, monitor failures and their consequences, lessen the likelihood of failures that might cause harm and take appropriate remedial actions. Buyer will fully indemnify TI and its representatives against any damages arising out of the use of any TI components in safety-critical applications.

In some cases, TI components may be promoted specifically to facilitate safety-related applications. With such components, TI's goal is to help enable customers to design and create their own end-product solutions that meet applicable functional safety standards and requirements. Nonetheless, such components are subject to these terms.

No TI components are authorized for use in FDA Class III (or similar life-critical medical equipment) unless authorized officers of the parties have executed a special agreement specifically governing such use.

Only those TI components which TI has specifically designated as military grade or "enhanced plastic" are designed and intended for use in military/aerospace applications or environments. Buyer acknowledges and agrees that any military or aerospace use of TI components which have **not** been so designated is solely at the Buyer's risk, and that Buyer is solely responsible for compliance with all legal and regulatory requirements in connection with such use.

TI has specifically designated certain components as meeting ISO/TS16949 requirements, mainly for automotive use. In any case of use of non-designated products, TI will not be responsible for any failure to meet ISO/TS16949.

Products

Audio	www.ti.com/audio
Amplifiers	amplifier.ti.com
Data Converters	dataconverter.ti.com
DLP® Products	www.dlp.com
DSP	dsp.ti.com
Clocks and Timers	www.ti.com/clocks
Interface	interface.ti.com
Logic	logic.ti.com
Power Mgmt	power.ti.com
Microcontrollers	microcontroller.ti.com
RFID	www.ti-rfid.com
OMAP Applications Processors	www.ti.com/omap
Wireless Connectivity	www.ti.com/wirelessconnectivity

Applications

Automotive and Transportation	www.ti.com/automotive
Communications and Telecom	www.ti.com/communications
Computers and Peripherals	www.ti.com/computers
Consumer Electronics	www.ti.com/consumer-apps
Energy and Lighting	www.ti.com/energy
Industrial	www.ti.com/industrial
Medical	www.ti.com/medical
Security	www.ti.com/security
Space, Avionics and Defense	www.ti.com/space-avionics-defense
Video and Imaging	www.ti.com/video

TI E2E Community

e2e.ti.com