

Check list use 120 CRB 75  
Intel confirm 120 Ohm

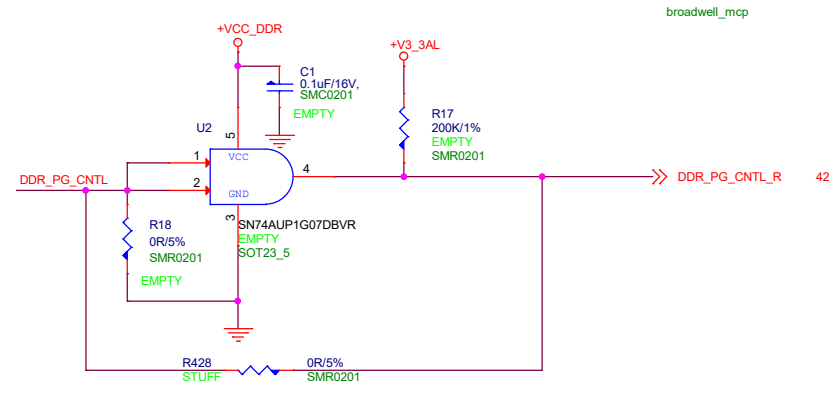

<b>.,Ltd.</b>		
<b>Intel BDWU</b>		
Size	Document Number	Rev
	<b>XX</b>	<b>V1</b>
Date:	Monday, October 12, 2020	Sheet 8 of 49

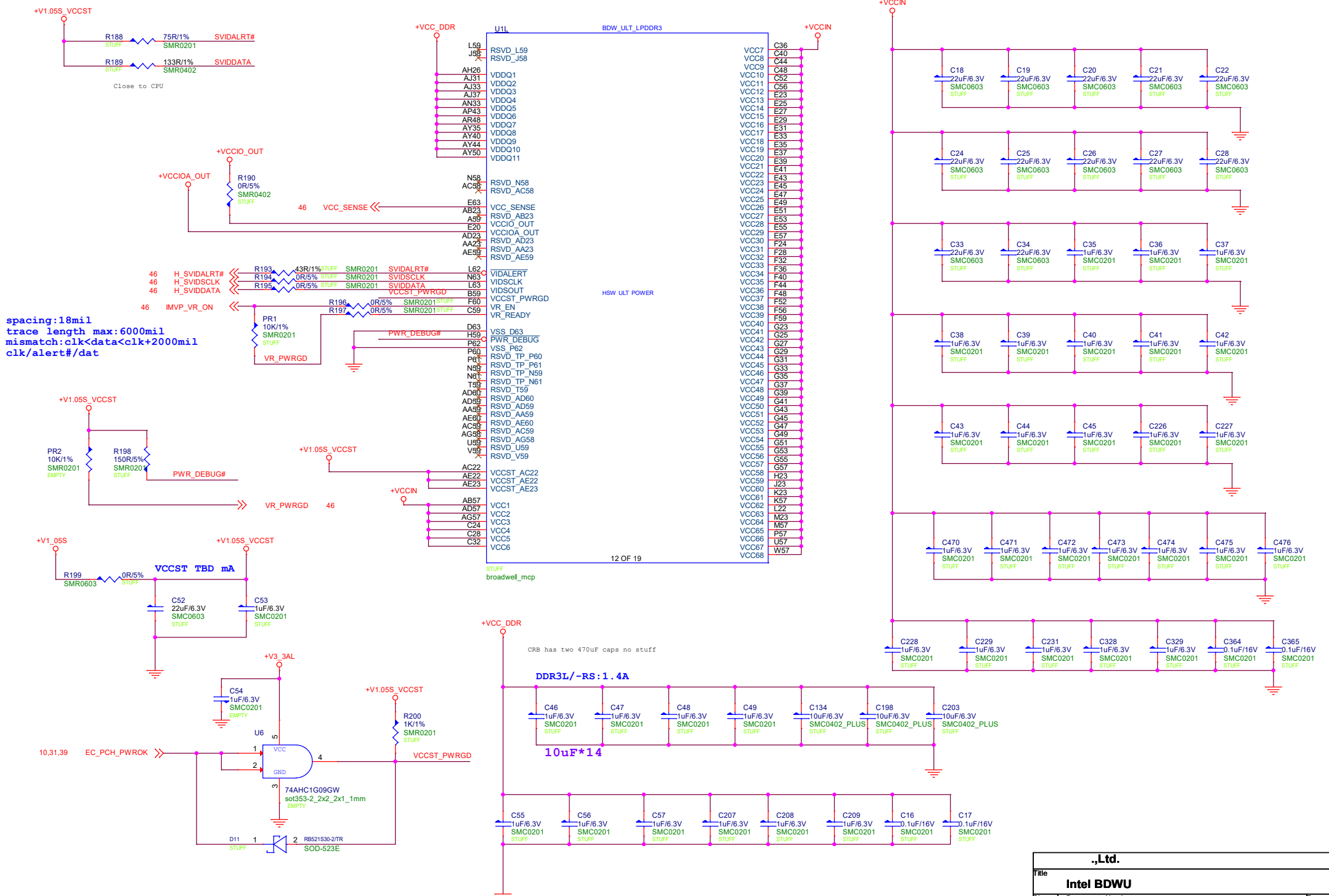

spacing:18mil  
 trace length max:6000mil  
 mismatch:clk<data<clk+2000mil  
 clk/alert#/dat

CRB has two 470uF caps no stuff

DDR3L/-RS:1.4A

10uF\*14

<b>.,Ltd.</b>		
File <b>Intel BDWU</b>		
Size	Document Number <b>XX</b>	Rev <b>V1</b>
Date:	Monday, October 12, 2020	Sheet 13 of 49

calculated 32A  
IccMax. Adjust  
F-IMAX divider  
for 40A.

V5A needs a local  
bypass capacitor at  
the controller min  
1uF effective

DNP PR162

Vref cap should be  
greater than  
330nF.  
Suggest 1uF

Double check drop vs. DCR  
sense value

add DNP placeholder  
for cap between  
COMP and DROOP

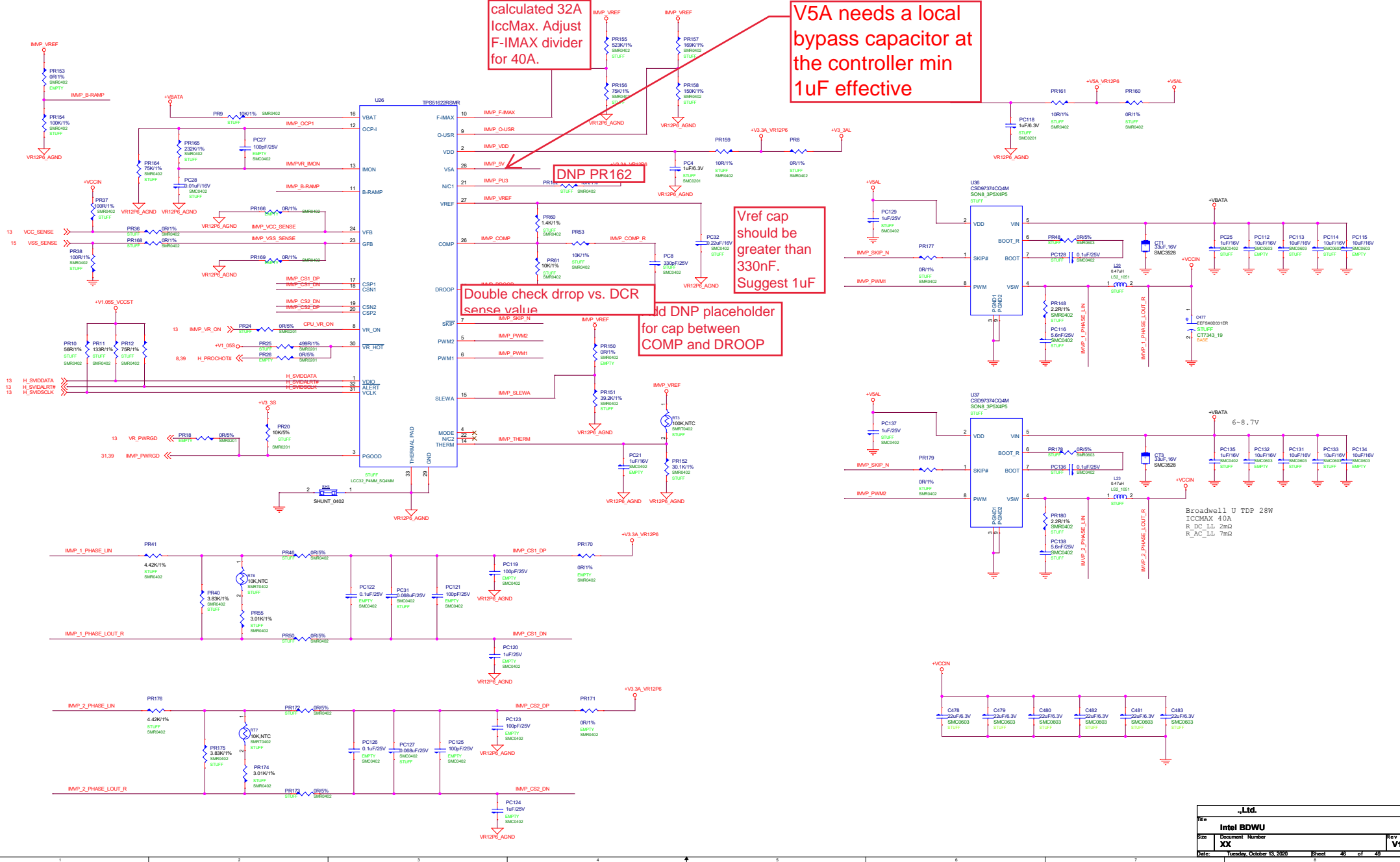

<b>Intel</b>	
<b>Intel BDWU</b>	
Docu	Docu
Number	Number
<b>XX</b>	<b>V1</b>
Date: Tuesday, October 13, 2020	Sheet 46 of 49