

VR12.0
 Phase# = 4 phases
 Fsw = 600 kHz
 Vboot = 0.92 V
 IMAx = 110 A
 Over current limit = 33 A per phase
 Slew rate fast = 0.68 mV/us
 Soft-Start Slew Rate Selection = 1/2 mV/us

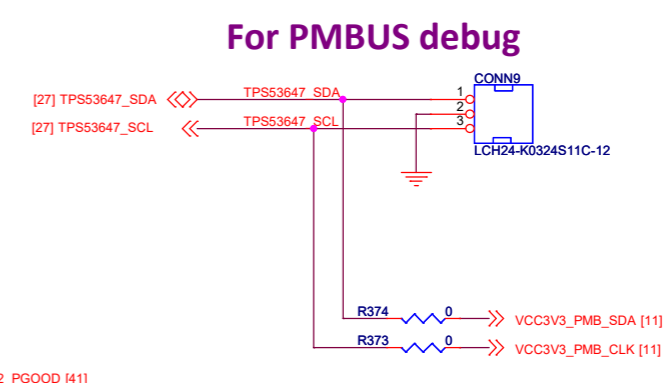
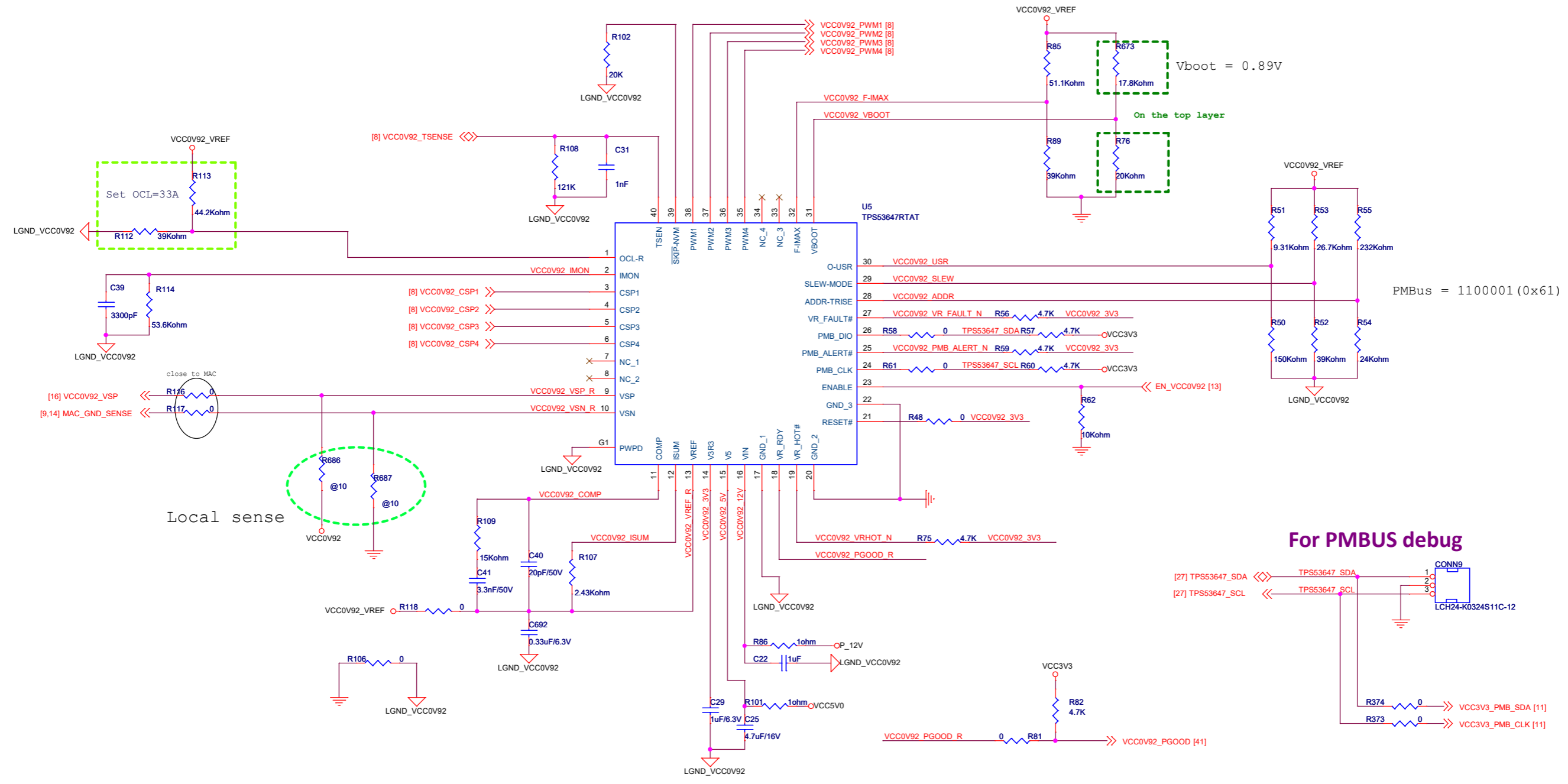

This document and the technical data disclosed are proprietary to Accton Tech. Corp. and shall not be duplicated, used, released, or disclosed without expressed written permission.

Accton
 Making Partnership Work

Model Name	ES5654BT3-0418-ZZ	Rev	R01
Page Name	PWR_VCC0.92V_Controller	Engineer	Alan
Date:	Friday, December 27, 2019	Sheet	7 of 47

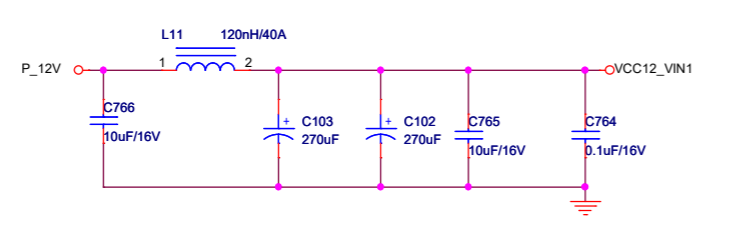
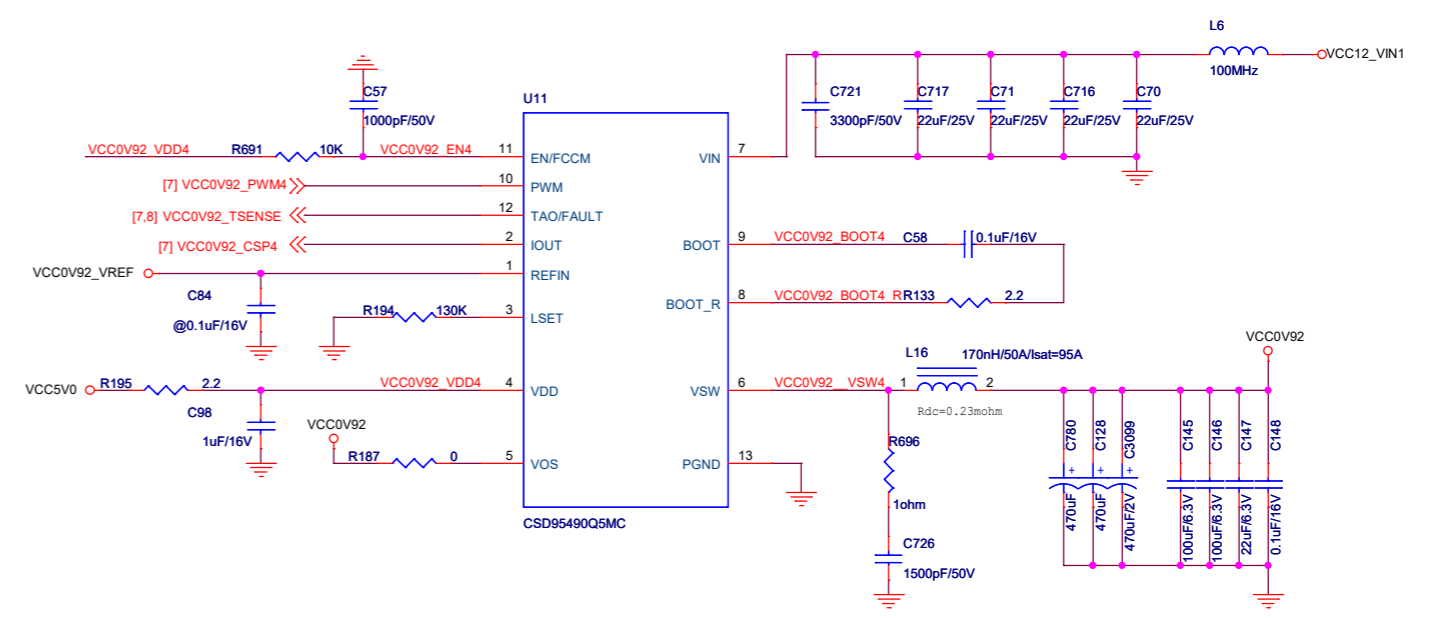
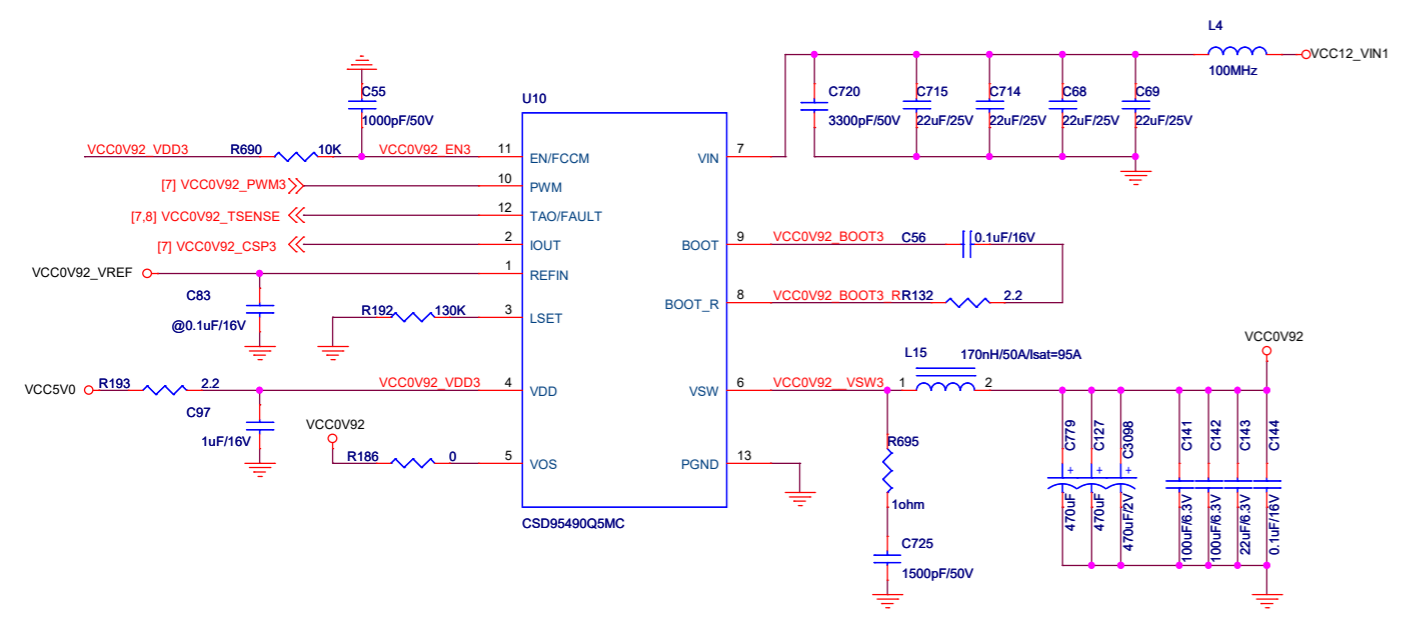
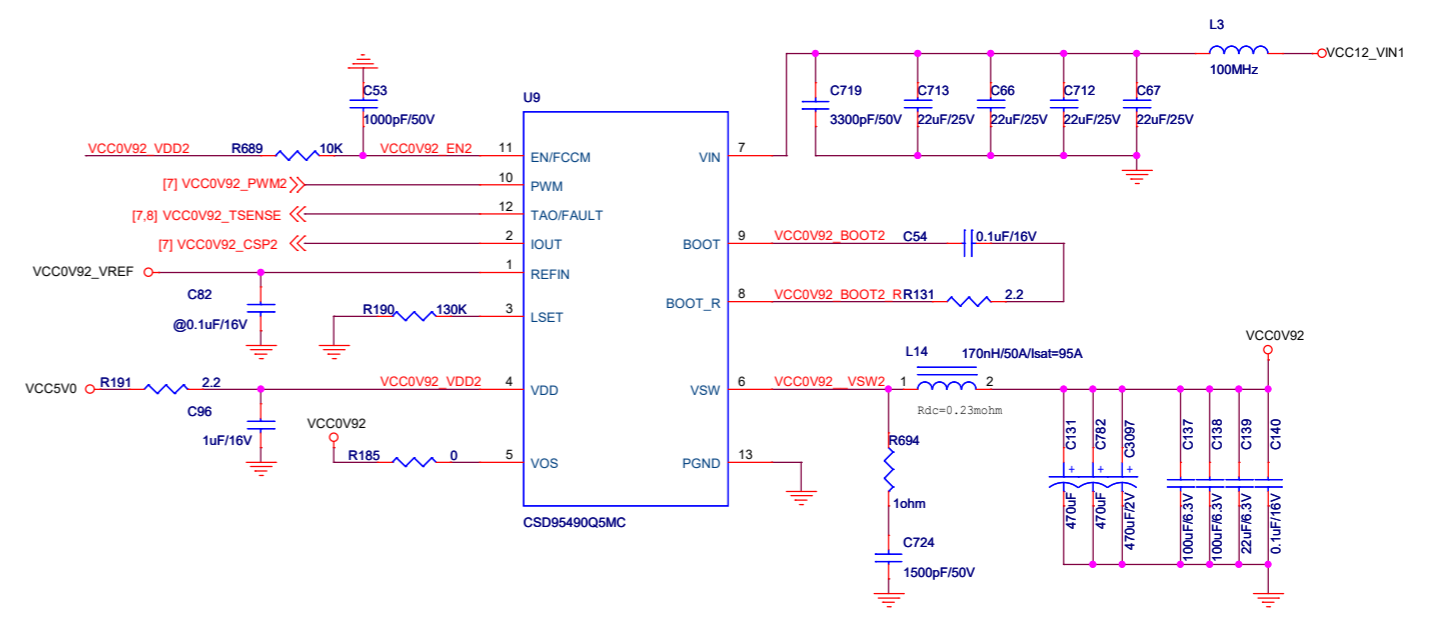
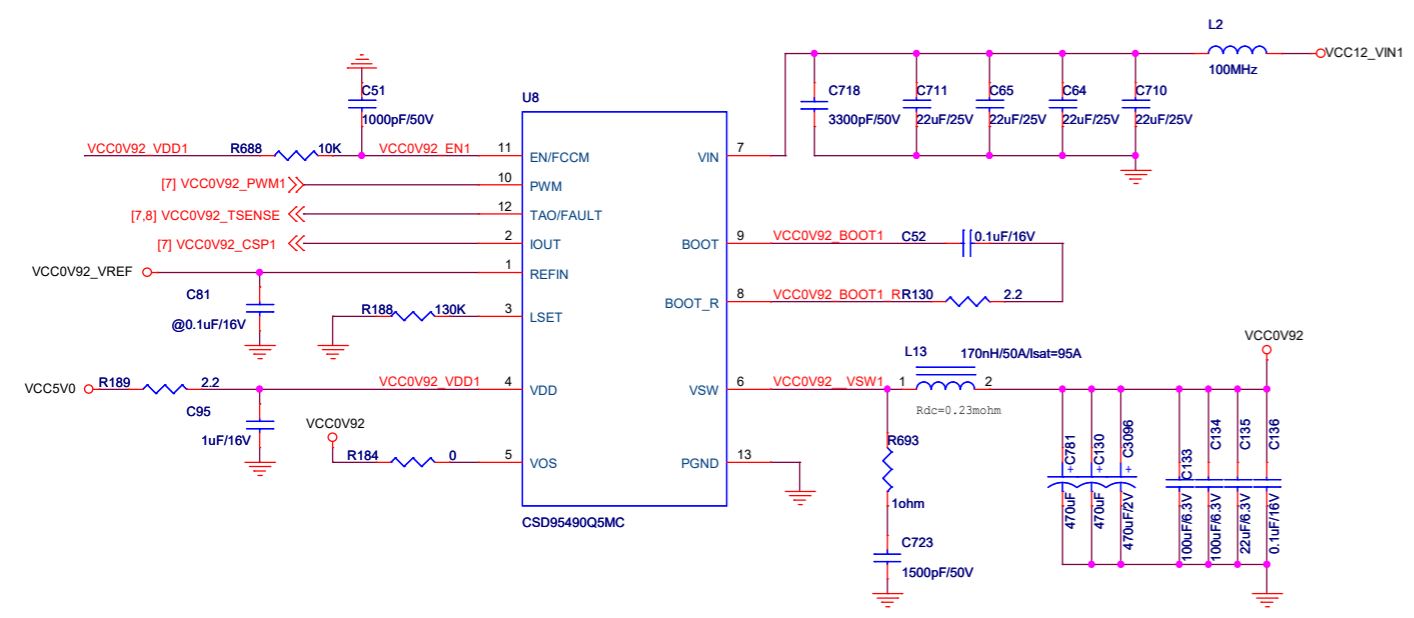

This document and the technical data disclosed are proprietary to Accton Tech. Corp. and shall not be duplicated, used, released, or disclosed without expressed written permission.

Accton
Making Partnership Work

Model Name: **ES5654BT3-0418-ZZ** Rev: R01

Page Name: PWR_VCC0.92V_Phases Engineer: Alan

Date: Friday, December 27, 2019 Sheet: 8 of 47