

## VOLTAGE CONVERSION 3.3V TO 1.05V

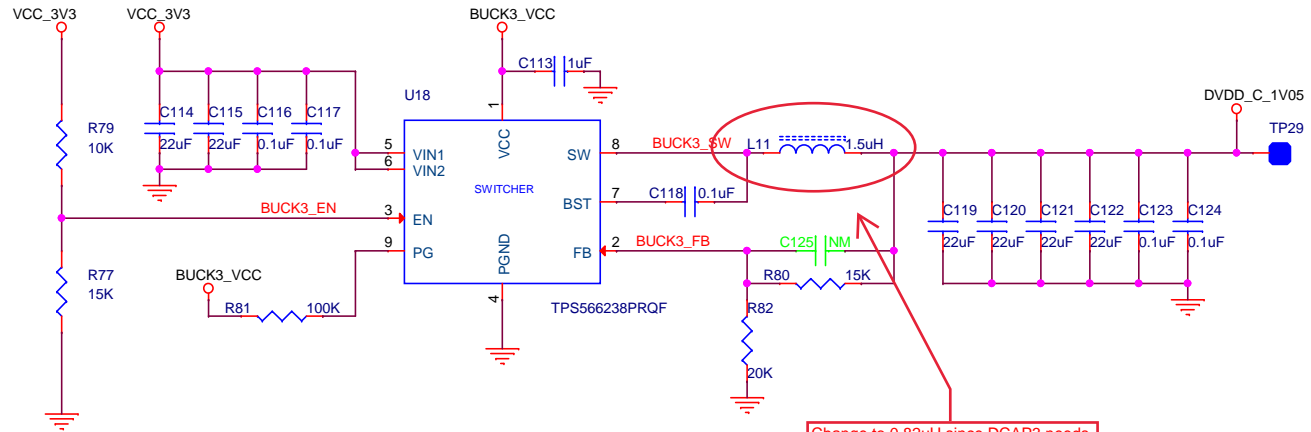

Change to 0.82uH since DCAP3 needs around 1.5A ripple current for stable system. Please refer to datasheet table 8-2. Remember your input is 3.3V, not 12V in table 8-2

Title		
<Title>		
Size	Document Number	Rev
A4	<Doc>	<Rev>
Date:	Wednesday, April 26, 2023	Sheet 1 of 1