

PMIC (AM335x Power)

PMIC (CPU Power)

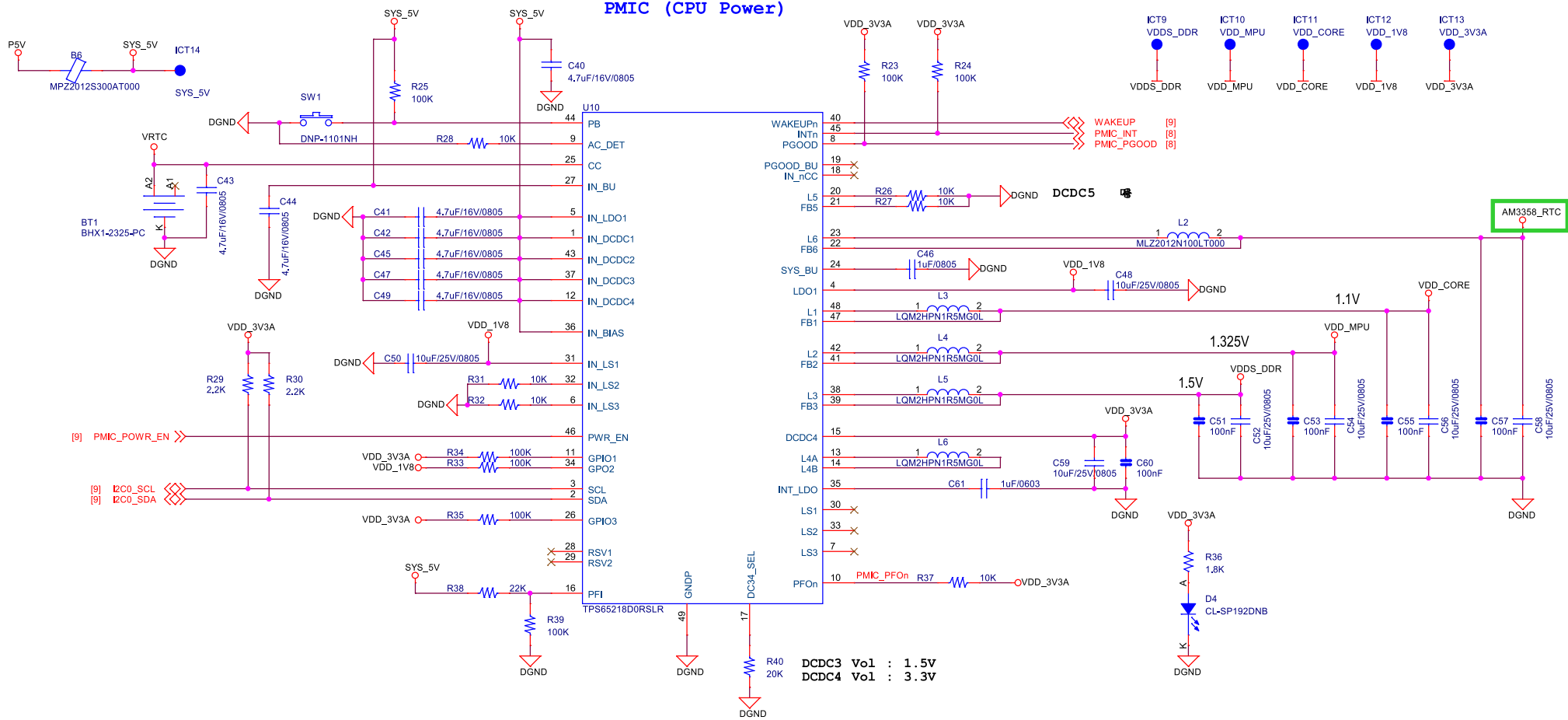

BT1
2.3mm 옆 PS R 및 둘
왼쪽 그림과 같이 되도록 권

APPROVALS		 Intellian Technologies, Inc. Innovation Centre, Global HQ 18-7, Jinwisandan-ro, Jinwi-myeon, Pyeongtaek-si, Gyeonggi-do, 451-882 Korea	
DRAWN : MG.LEE			
CHECKED :		TITLE:	
APPROVED:		mPower_mP85L	
ENGINEER : MG.LEE		SIZE	DWG NO.
ARTWORK :		A3	05. POWER 2/2
DATE: Monday, December 18, 2023		REV	A
SHEET 5 OF 23			

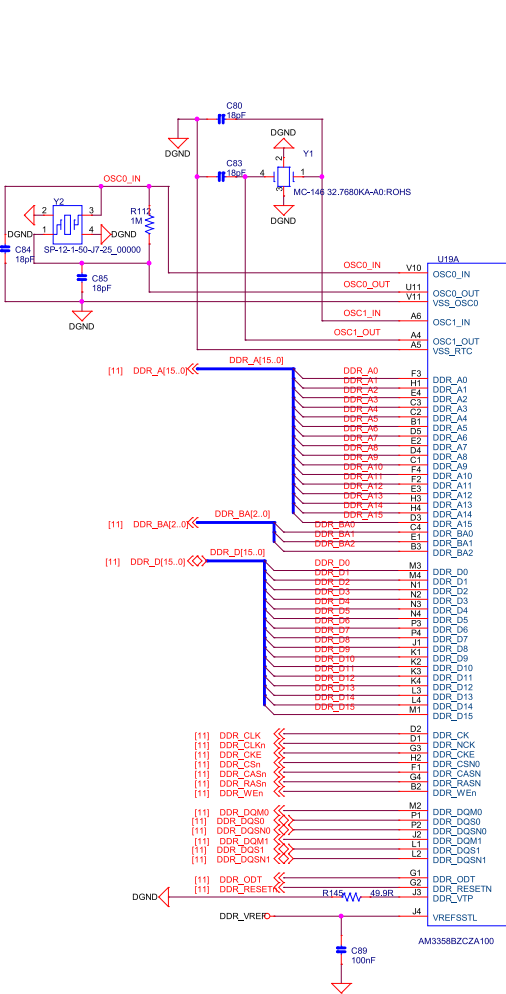

SubArctic AM335x

15mm x 15mm Package

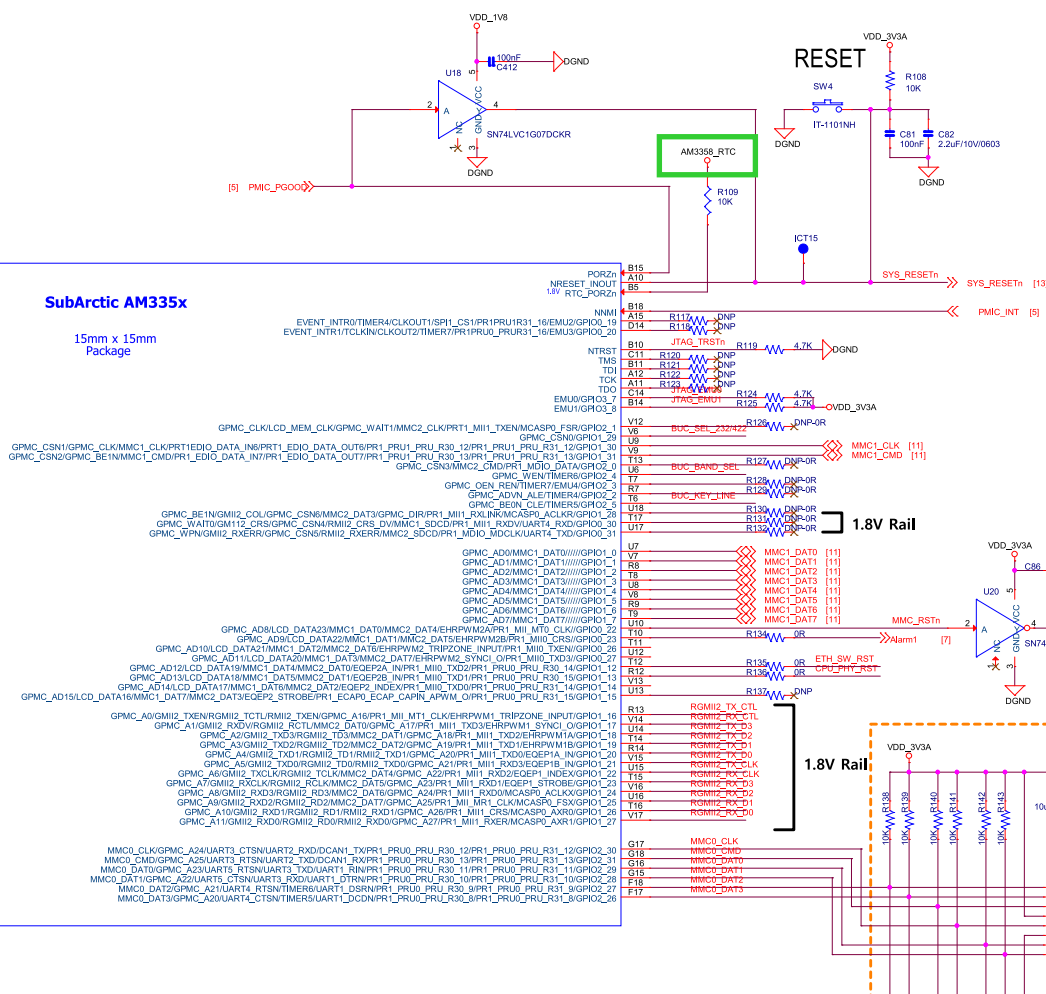
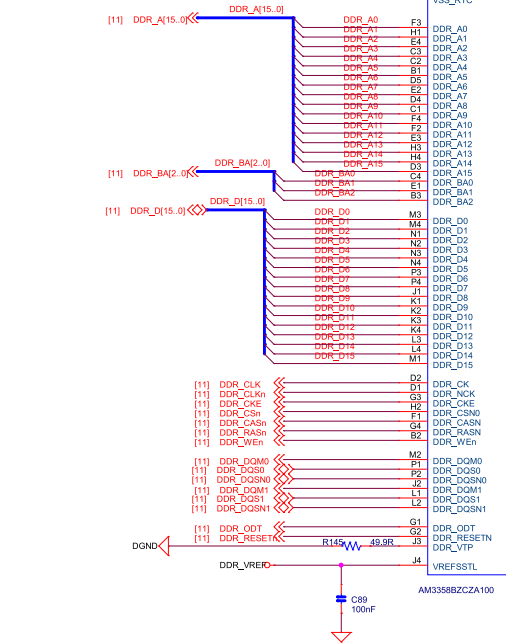

ETH RESET

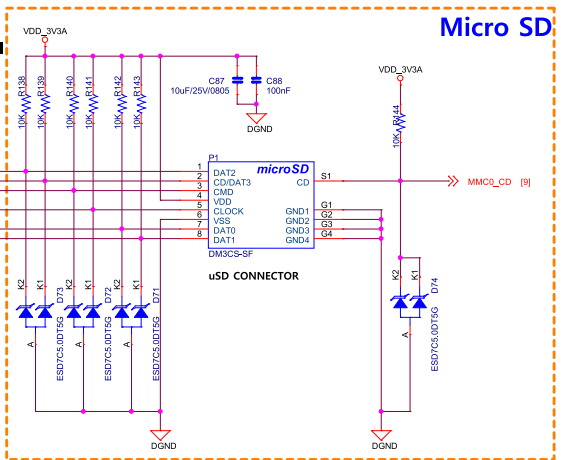
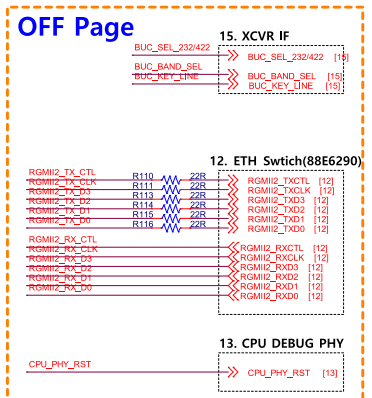
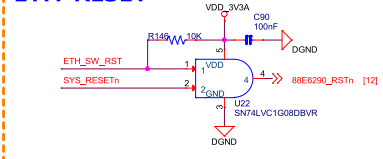

APPROVALS		<p>Intellian Technologies, Inc. Innovation Centre, Global HQ 19-7, Jinwi-daero, Jinwi-myeon, Pyeongtaek-si, Gyeonggi-do, 481-862 Korea</p>
DRAWN :	MG.LEE	
CHECKED :		
APPROVED :		
ENGINEER :	MG.LEE	
ARTWORK :		TITLE: mPower_mp85L SIZE: A3 DATE: Monday, December 18, 2023
		DWG NO. 08. AIU (AM335x 1/3) REV A
		SHEET 8 OF 23

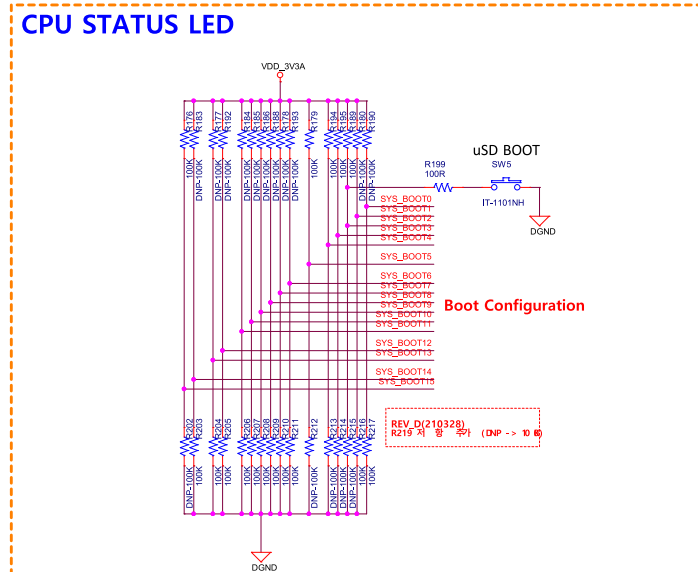
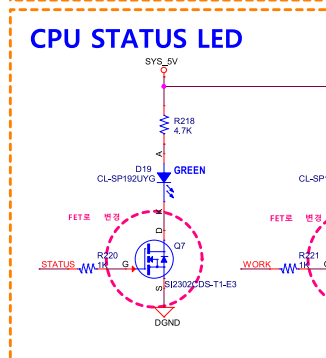
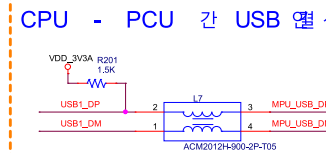
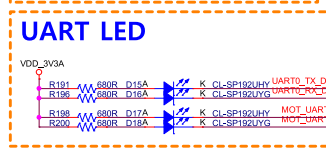
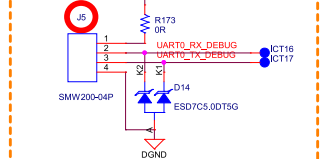

SYSBOOT[15:14]	SYSBOOT[13:12]	SYSBOOT[11:10]	SYSBOOT[9]	SYSBOOT[8]	SYSBOOT[7:6]	SYSBOOT[5]	SYSBOOT[4:0]	Boot Sequence
00b = 19.2MHz 01b = 24MHz 10b = 25MHz 11b = 26MHz	00b (all other values reserved)	Don't care for ROM code	Don't care for ROM code	Don't care for ROM code	Don't care for ROM code	11100b	MMMC1	MMCO UART0 USB[0:5]
00b = 19.2MHz 01b = 24MHz 10b = 25MHz 11b = 26MHz	00b (all other values reserved)	Don't care for ROM code	Don't care for ROM code	Don't care for ROM code	Don't care for ROM code	11000b	SPI0	MMCO USB[0:5] UART0

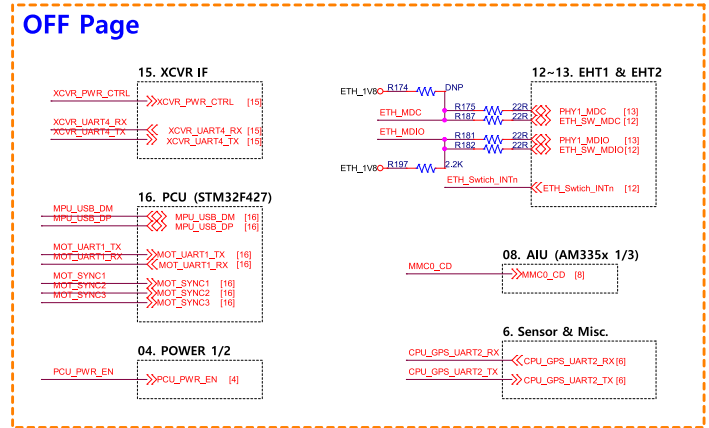

APPROVALS		Intellian Intellian Technologies, Inc. Innovation Centre, Global HQ
DRAWN : MG.LEE	CHECKED : MG.LEE	
APPROVED :	ENGINEER : MG.LEE	mPower_mp85L
ARTWORK :	SIZE : A3	
DATE : Monday, December 18, 2023	REVISION : 09. AIU (AM335x 2/3)	REV : A

18-7, Jinjwada-ro, Jinju-myeon, Pyongsang-si, Gyeonggi-do, 461-862 Korea

SHEET 9 OF 23

