

MULTICHANNEL BUCK CONVERTER 1

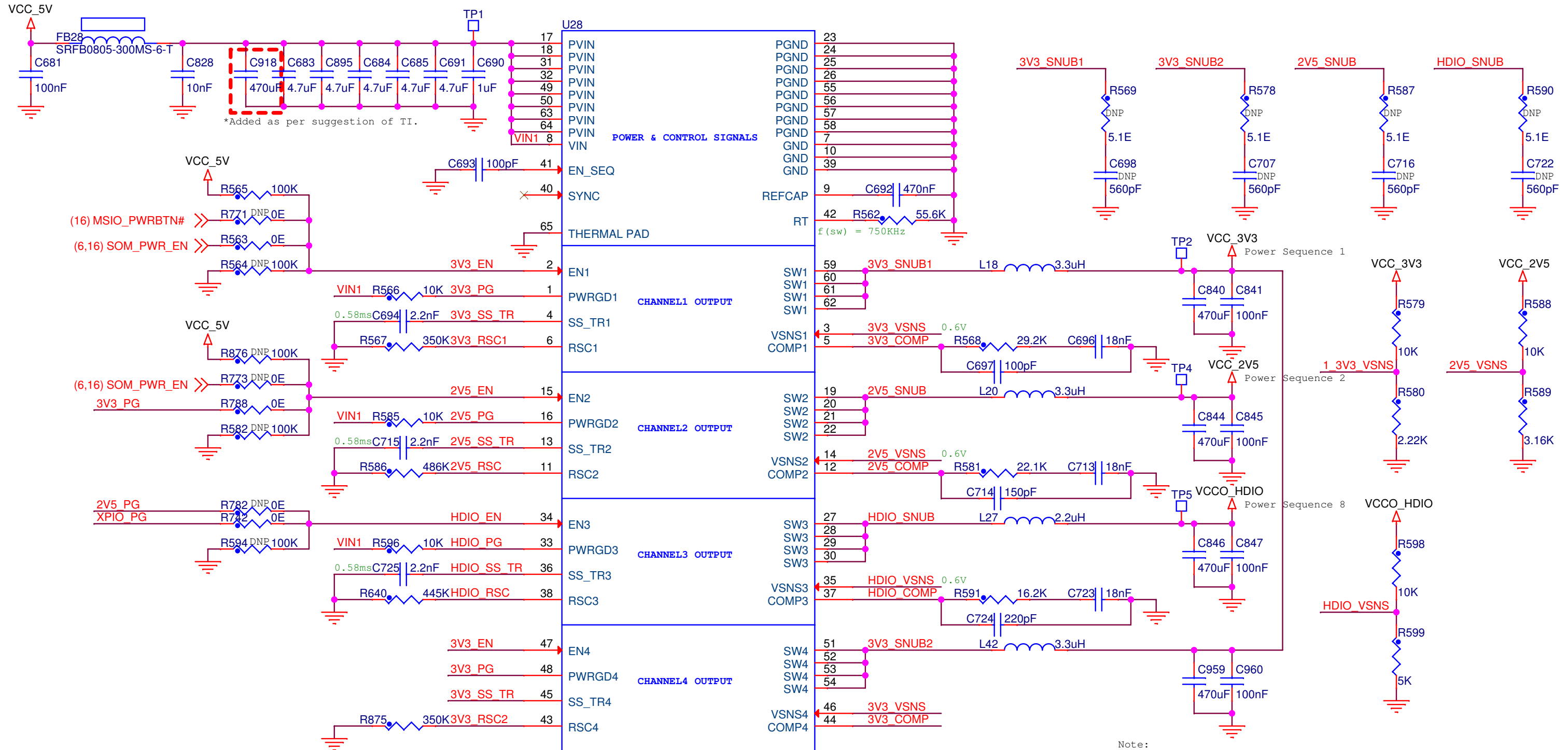

- CAD Note:
1. GND pin should be tied to THERMAL PAD.
 2. THERMAL PAD should be connected to internal GND layers through vias.
 3. Discrete components of VSNS, RT & COMP pins should be placed close to the IC with minimal trace length.
 4. Place the inductor near to the SW pins.

Note:
 By default, VCCO_HDIO is configured as 1.8V.
 For configuring VCCO_HDIO as 3.3V, the following changes are required:
 *Change R640 to 350K.
 *Change L27 to 3.3uH (P/N: SPL33-07).
 *Change R591 to 29.2K.
 *Change C724 to 100pF.

MULTICHANNEL BUCK CONVERTER 2

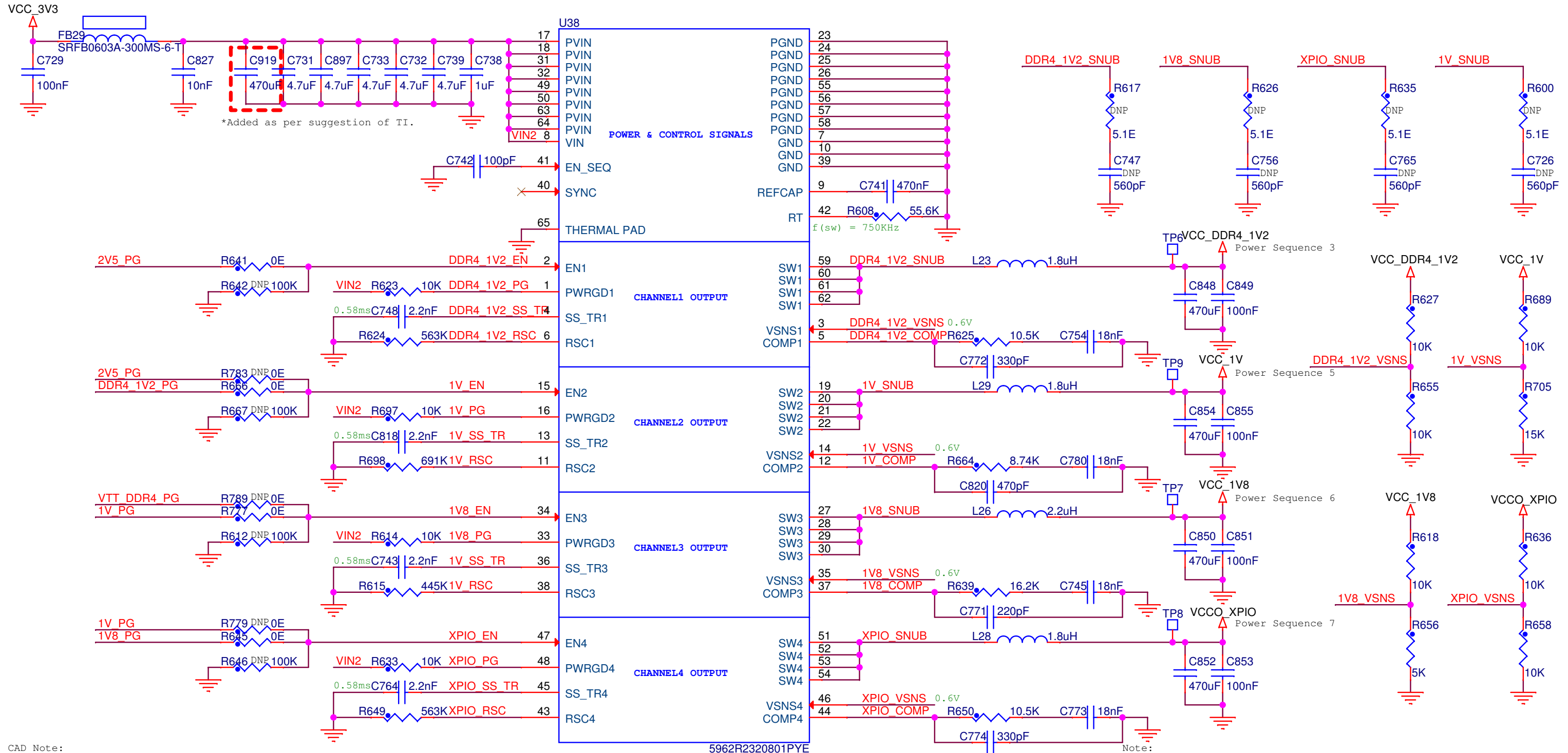

CAD Note:
 1. GND pin should be tied to THERMAL PAD.
 2. THERMAL PAD should be connected to internal GND layers through vias.
 3. Discrete components of VSNS, RT & COMP pins should be placed close to the IC with minimal trace length.
 4. Place the inductor near to the SW pins.

Note:
 By default, VCCO_XPIO is configured as 1.2V.
 For configuring VCCO_XPIO as 1.5V, the following changes are required:
 *Change R649 to 436K.
 *Change R650 to 13.3K.
 *Change C774 to 220pF.

MULTICHANNEL BUCK CONVERTER 3

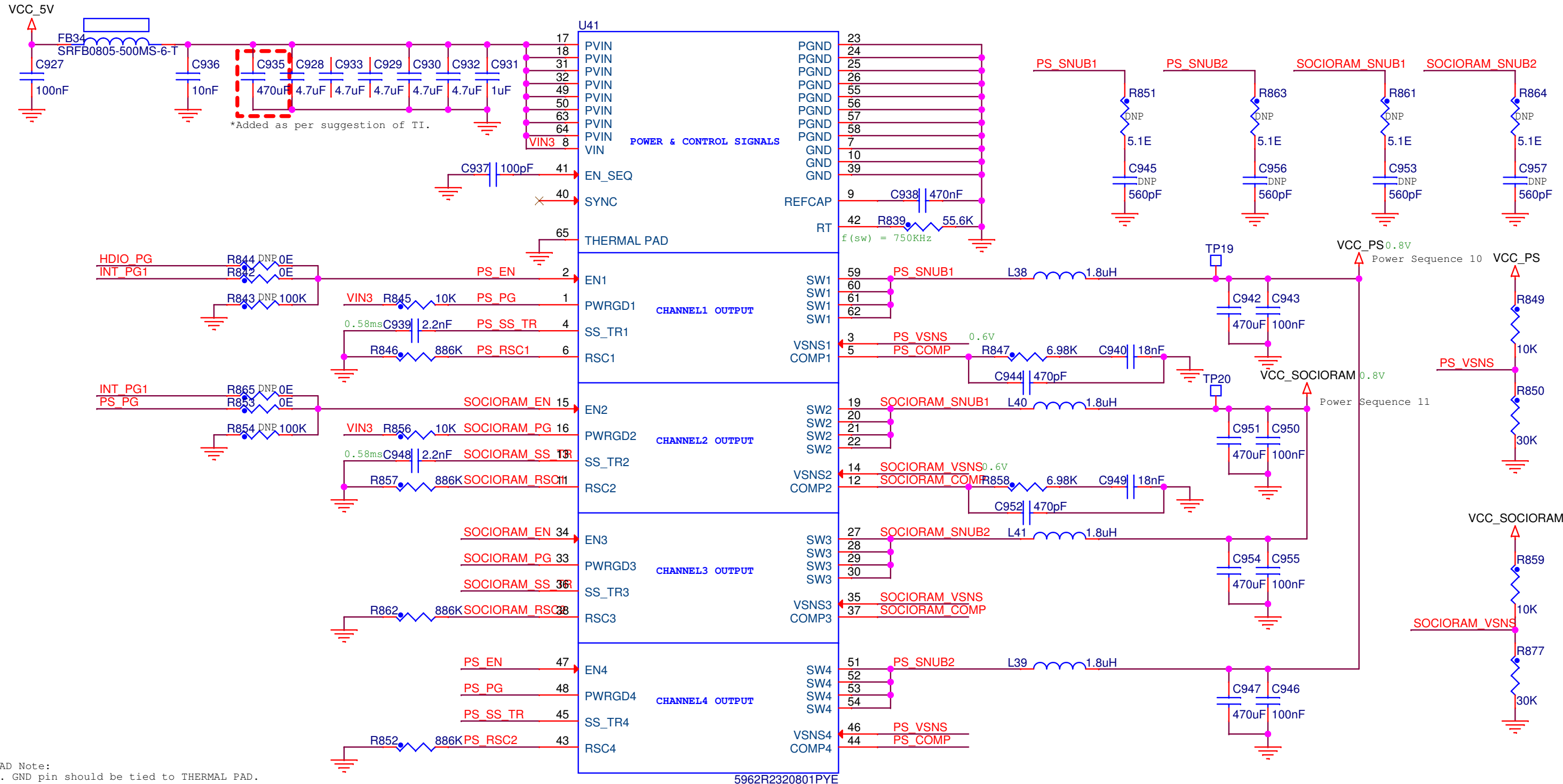

CAD Note:
 1. GND pin should be tied to THERMAL PAD.
 2. THERMAL PAD should be connected to internal GND layers through vias.
 3. Discrete components of VSNS, RT & COMP pins should be placed close to the IC with minimal trace length.
 4. Place the inductor near to the SW pins.

MULTICHANNEL BUCK CONVERTER 4

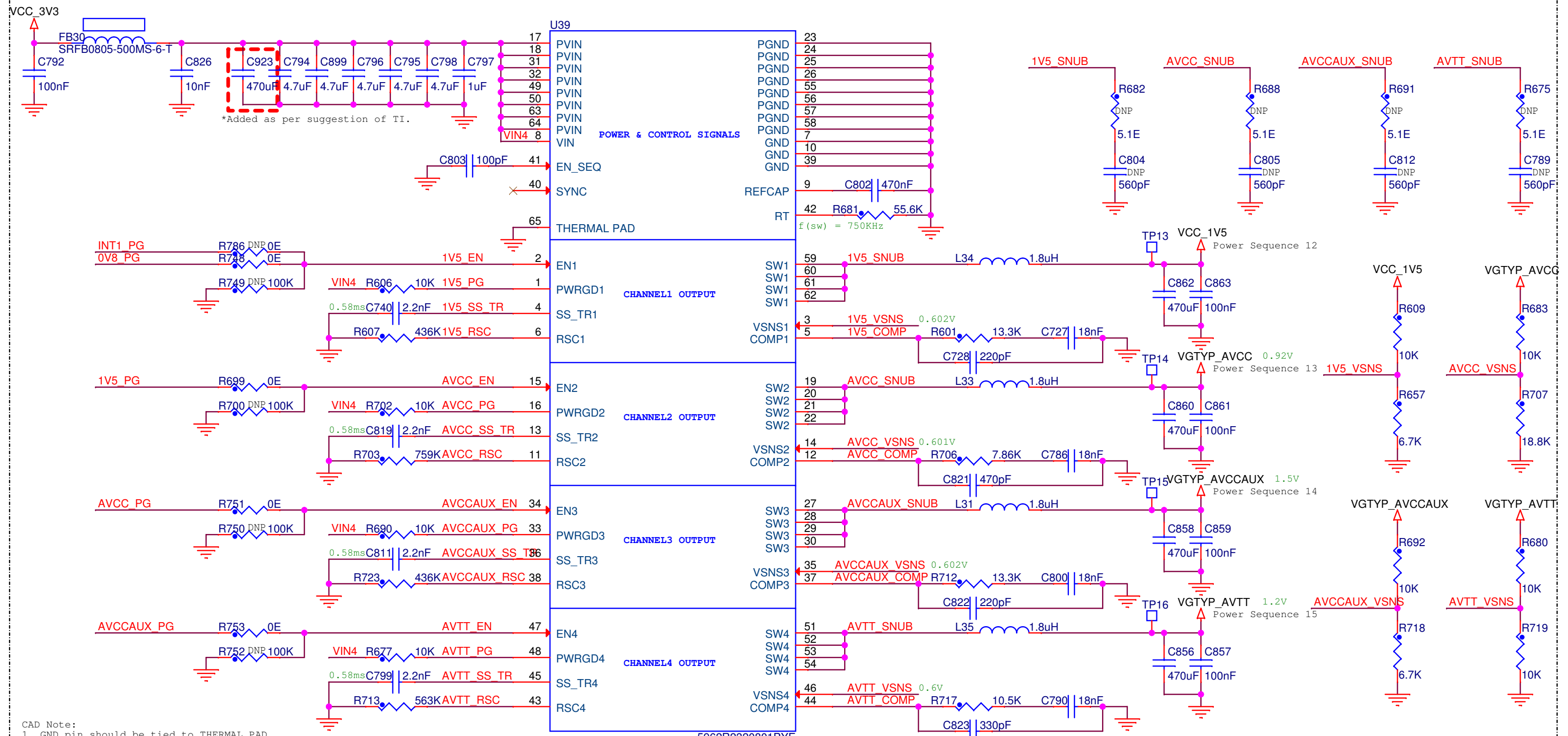

CAD Note:
 1. GND pin should be tied to THERMAL PAD.
 2. THERMAL PAD should be connected to internal GND layers through vias.
 3. Discrete components of VSNS, RT & COMP pins should be placed close to the IC with minimal trace length.
 4. Place the inductor near to the SW pins.