

12V to 3.3V 2A regulator

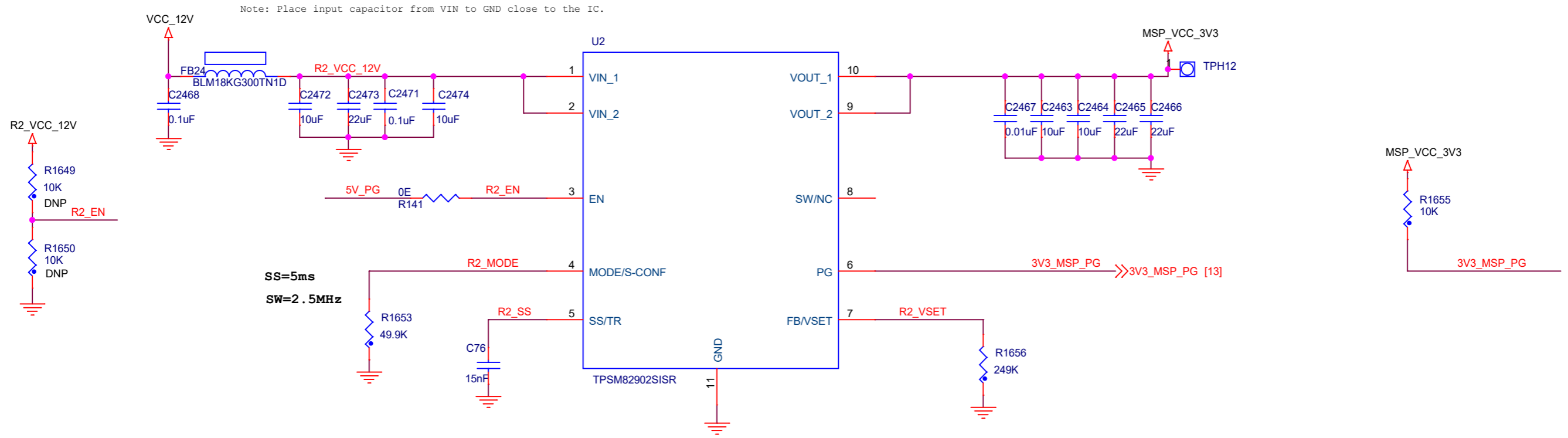

5V to 0.85V 2A regulator

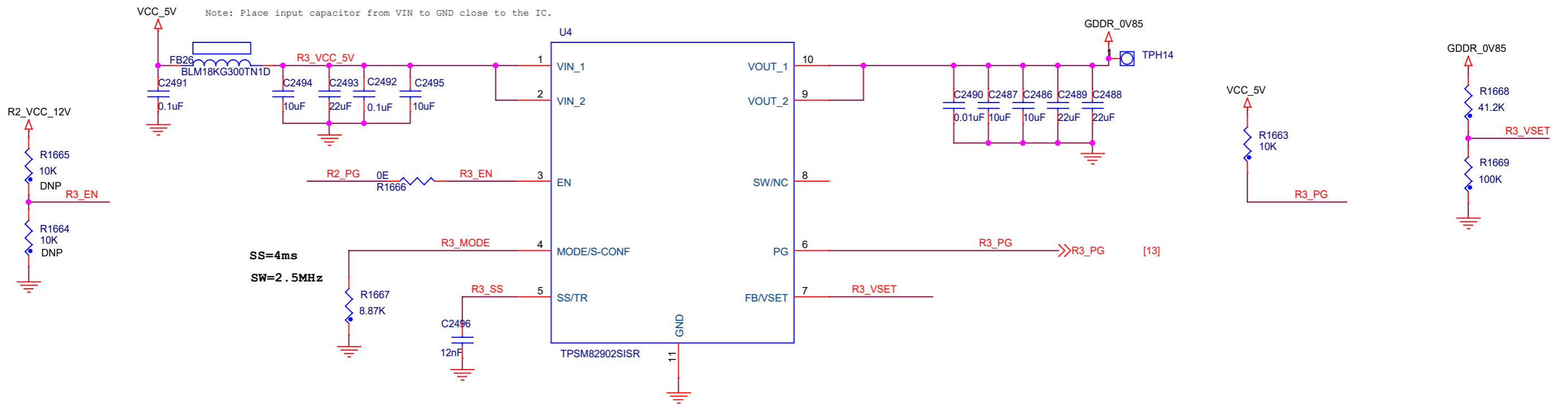

5V to 1.35V 2A regulator

Note: Place input capacitor from VIN to GND close to the IC.

