

**NOTE:**  
 1. The TPSM831D31's Non-Volatile Memory (NVM) must be configured to the desired nominal voltages. This configuration should take place during board bring-up using a TI adapter (USB to I2C).

2. BRCM SW cannot manage or boot up until the VDDC/CPU\_VDDC power supplies are first set to their nominal voltage.

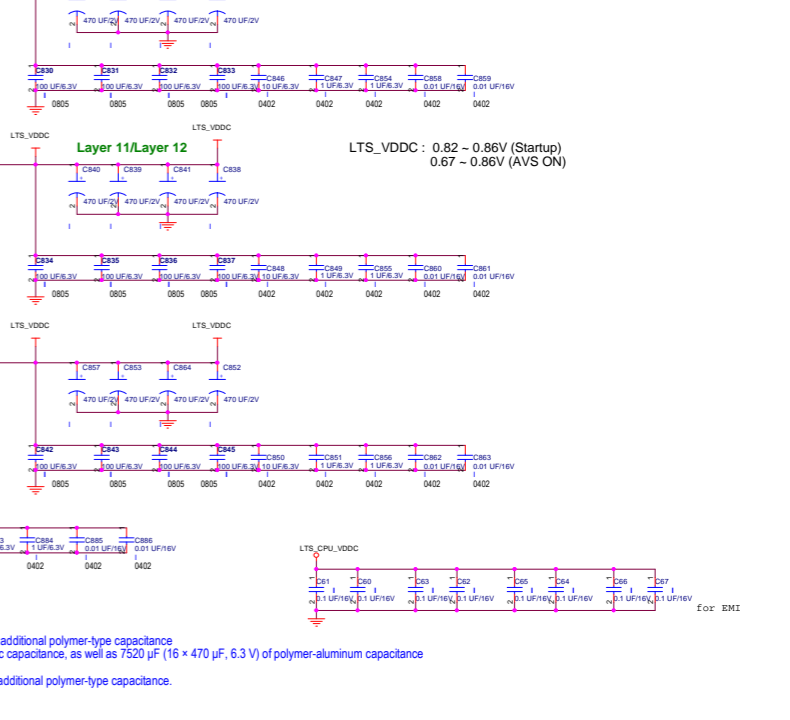
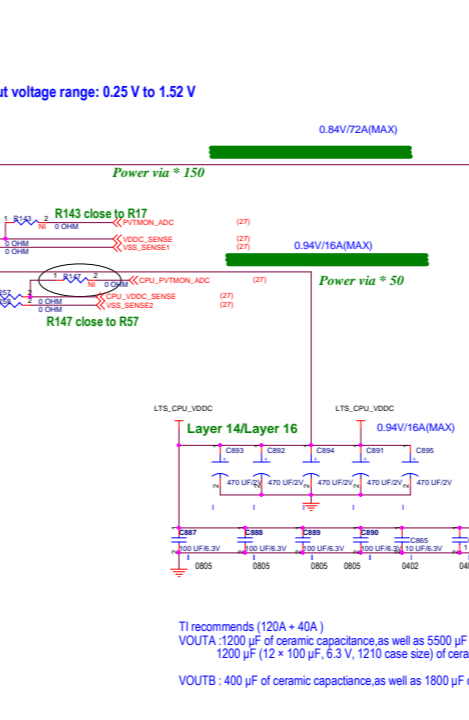
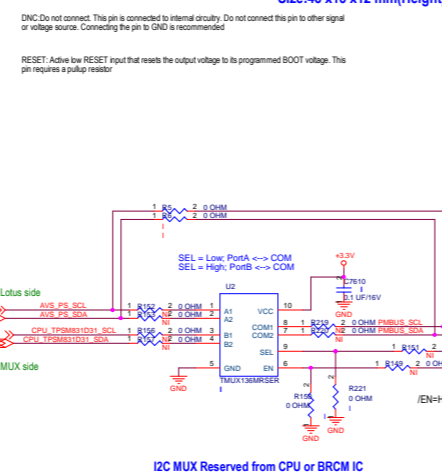
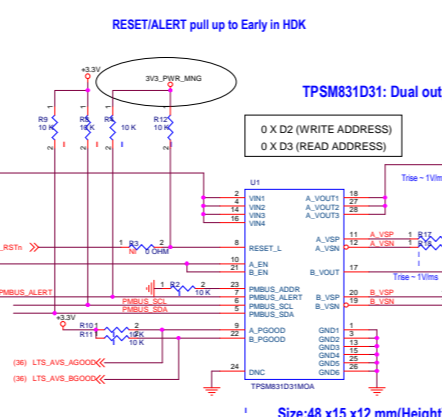
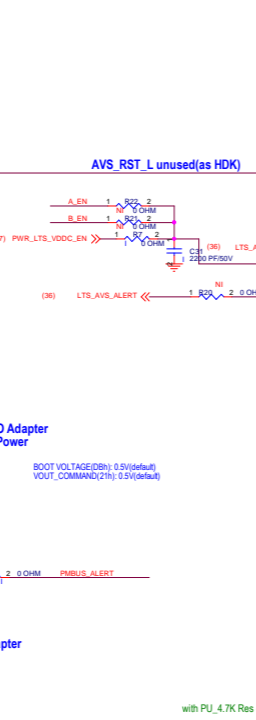
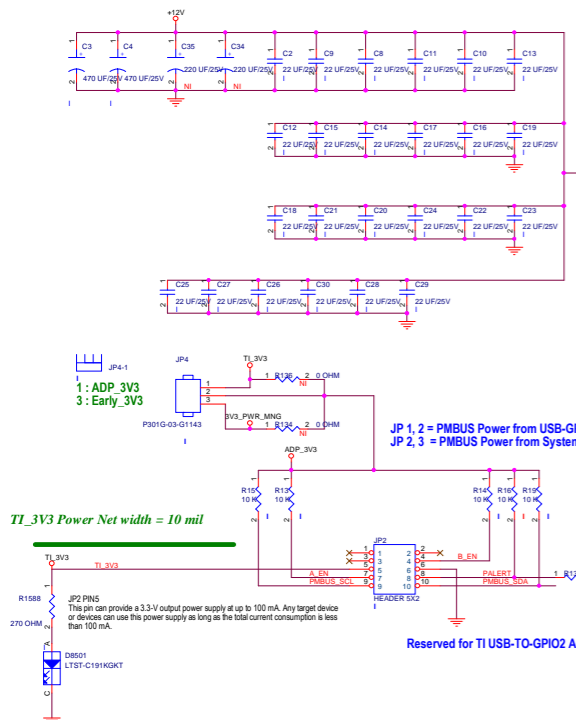

D/D PMBUS from BCM6660 (default)  
 Reserved for CPU Programming NVM

Reserved for TI USB-TO-GPIO2 Adapter

I2C MUX Reserved from CPU or BRCM IC