

V20_20220502

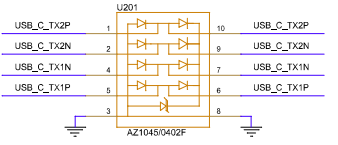

CTL1	CTL0	FLIP	Mux Operation
LOW	LOW	LOW	POWER DOWN
LOW	LOW	HIGH	POWER DOWN
LOW	HIGH	LOW	One Port USB3.1 No FLIP
LOW	HIGH	HIGH	One Port USB3.1 With FLIP
HIGH	LOW	LOW	4 Lane DP No FLIP
HIGH	LOW	HIGH	4 Lane DP With FLIP
HIGH	HIGH	LOW	1 Port USB3.1 + 2 Lane DP No FLIP
HIGH	HIGH	HIGH	1 Port USB3.1 + 2 Lane DP With FLIP

V30_CHG17: Modify TUSB1146IRNQT symbol, Type C connector and Circuit (4 lanes DDI Signal)

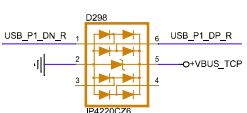
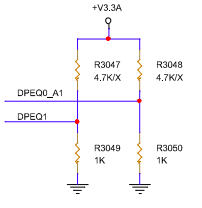
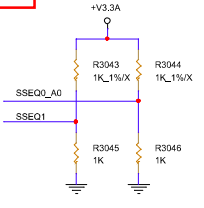
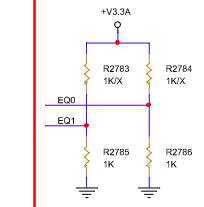
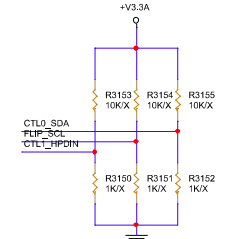
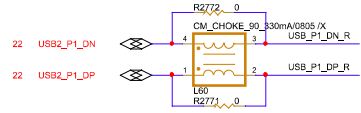
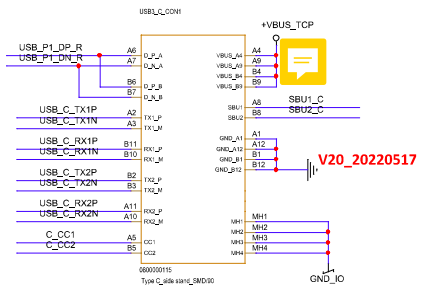
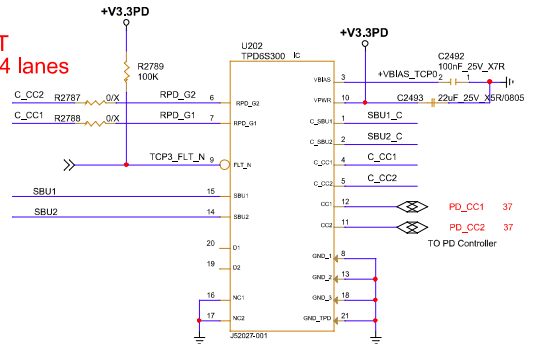

V20_20220517

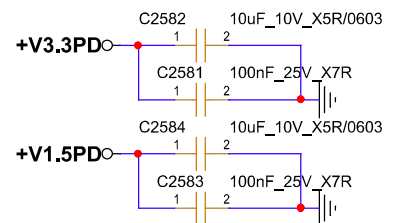
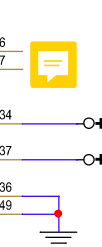
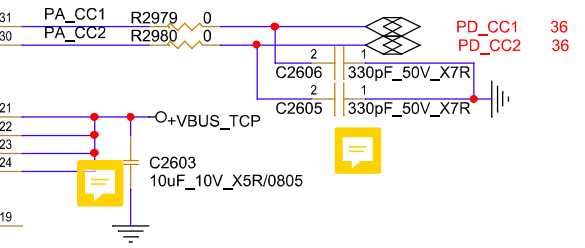
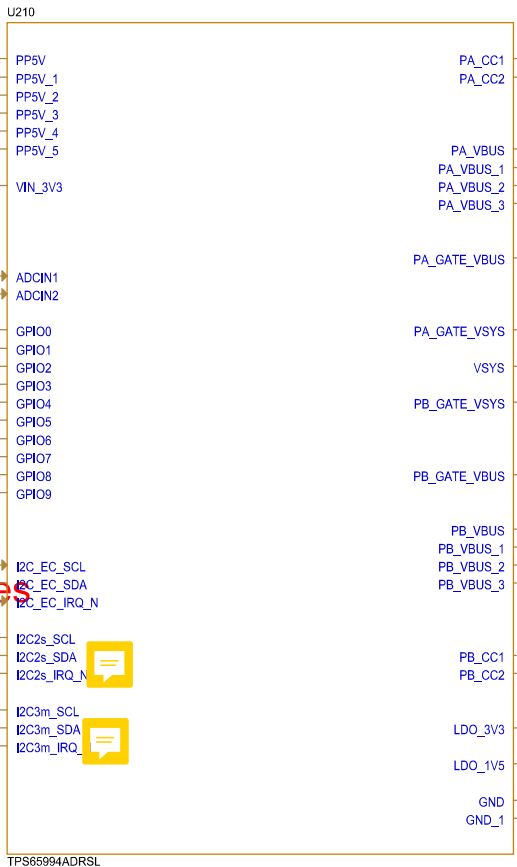
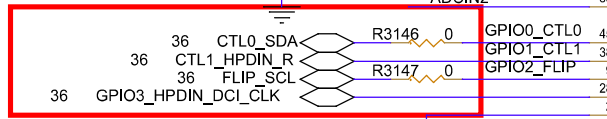
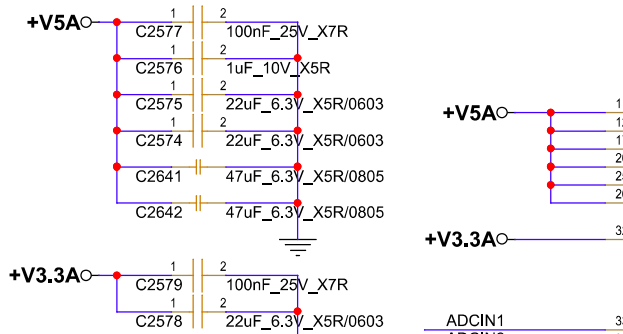

V30_CHG17: Modify TUSB1146IRNQT symbol, Type C connector and Circuit (4 lanes DDI Signal)

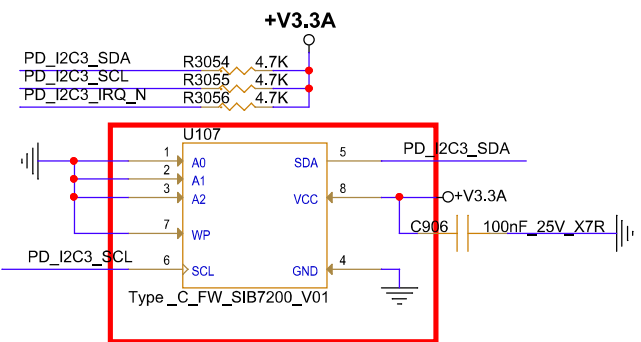
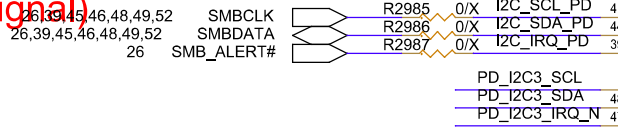

V30_CHG09: U107 replace to 1Mbit EEPROM

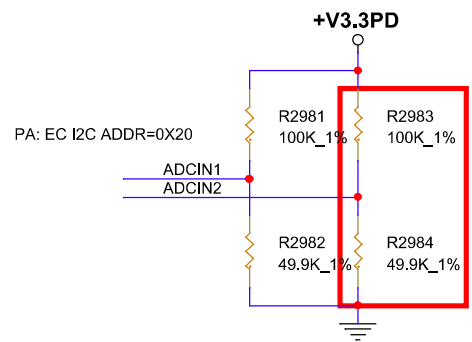

V30_CHG10: Install R2983 100K_1%,