

Atish - Phase Selection

Version	Changes
V0.1	<ul style="list-style-type: none">- Changed to a rail to rail opamp.- Corrected the filter values for correct cutoff frequencies.- Changed the overall gain to 20x- Removed voltage divider Resistors.- Added a voltage reference with buffer.-

OpAmp Selection

I have chosen the MCP6002 from Microchip as we are already using the PIC microcontroller from MCP. This is a single voltage rail to rail dual opamp.

Filter calculation

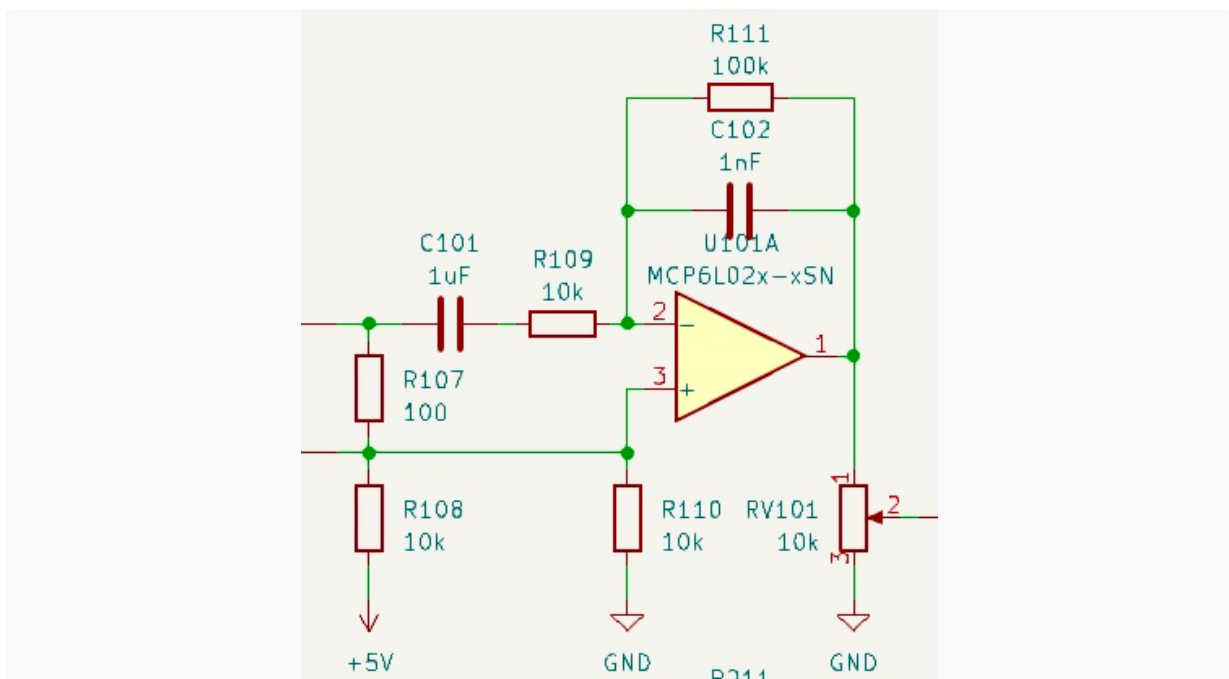

This is a band pass filter with following characteristics:

- Gain: 10
- Calculated Low Cutoff Frequency: 45Hz
- Calculated High Cutoff Frequency: 55Hz

Gain of 10 is achieved by the ratio between R111 and R109; In fact it is -10 because it is an inverting opamp circuit

$$Gain = \frac{R111}{R109} = \frac{100k}{10k} = 10$$

The High Cutoff Frequency with the given values was:

$$HCF = \frac{1}{2 * \pi * C101 * R109} = \frac{1}{2 * \pi * 1 * 10^{-6} * 1 * 10^4} = \pm 16Hz$$

With the given resistance value required for the gain to be 10, C101 becomes:

$$C101 = \frac{1}{2 * \pi * HCF * R109} = \frac{1}{2 * \pi * 55 * 1 * 10^4} = \pm 290nF$$

The Low Cutoff Frequency with the given values was:

$$LCF = \frac{1}{2 * \pi * C102 * R111} = \frac{1}{2 * \pi * 1nF * 100K} = \pm 1600Hz$$

With the given resistance value required for the gain to be 10, C102 becomes:

$$C102 = \frac{1}{2 * \pi * LCF * R111} = \frac{1}{2 * \pi * 45 * 100k} = \pm 35nF$$

Sense value and opamp set point

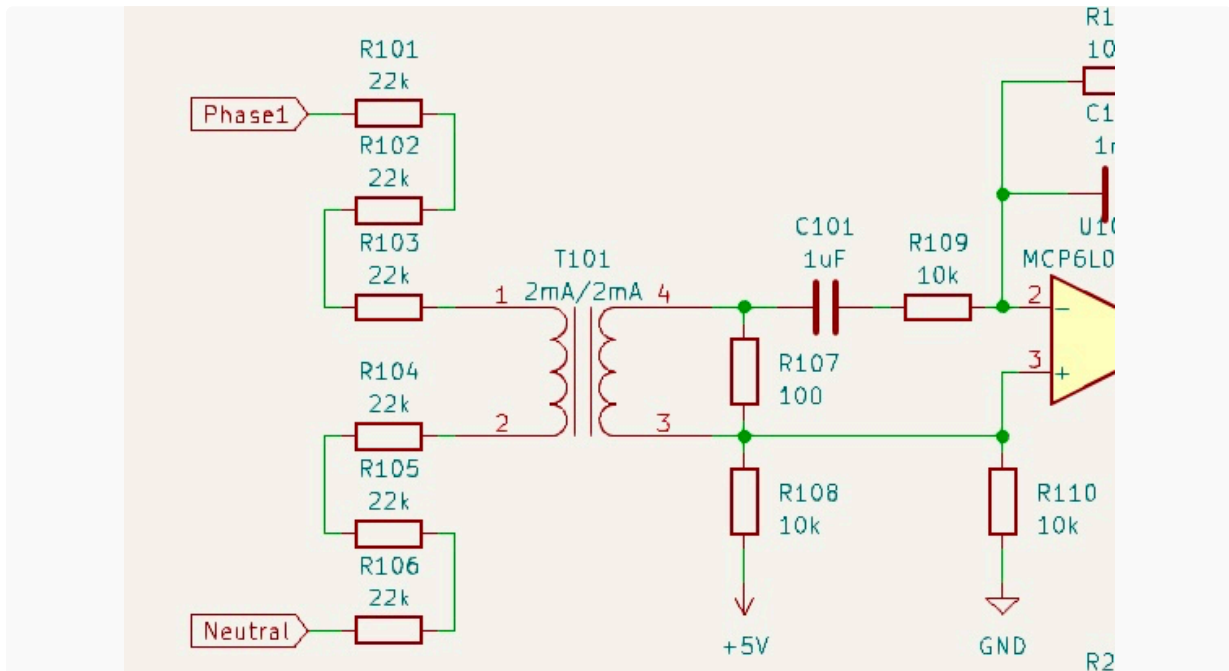

Phase1 and Neutral carry 230Vrms over $6 * 22k + 150$; the peak current is therefore:

$$I_{T101} = \frac{\sqrt{2} * 230}{6 * 22 * 10^3 + 150} = 2.46mA$$

The recommended current value is around 1.5mA. This requires the resistors R101-R106 to be 33k. This results in a current of 1.64mA.

R107 is the sampling resistor with the recommended value of 100R. The peak voltage over this resistor is therefore 164mV. This voltage is superimposed on the 2.5V created by R108 and R110 and supplied to the opamp where it is filtered and amplified by 10.

Alternatively a common voltage reference could be used for the 6 opamps and the MCU.

The output from the first stage is therefore 2.5V +/- 1.64V or 0.86V to 4.14V. This also means that the second stage doesn't require 10x gain and the resistor and capacitor values will be modified accordingly. I opted for a 2x gain setup to allow for fine-tuning and calibration using the potmeter.

Sampling method vs. bridge rectifier.

Given that the cycle time is 20ms, the positive peak of the signal will fall at around 5ms after a negative to positive zero crossing. Starting a sampling cycle at this point and provided that enough samples are taken, the peak will be recognized without the need for rectification of the signal. This avoids having to add additional (non-linear) circuitry.

The sampling cycle has to be started for the three phases separately due to the 120° phase difference. Depending on the speed of the processor this could be a few cycles apart.