

Hello

I am using the UCC2819A.

Currently, I make boats and evaluate them.

In the evaluation, noise was generated and investigated

. Therefore we measured the threshold using the circuit in Figure 1 of the device with abnormal noise and the normal device.

The voltage of VI is changed in FIG. Pulsed out at DRVOUT. Measure the voltage of VAI-pin.

The result is shown in Table 1.

Question

The NG sample is pulsed at VAI pin voltage = 0V DRVOUT. The OK sample comes out at 0.5V.

Why does it pulse at VAI pin voltage = 0V DRVOUT?

Thank you.

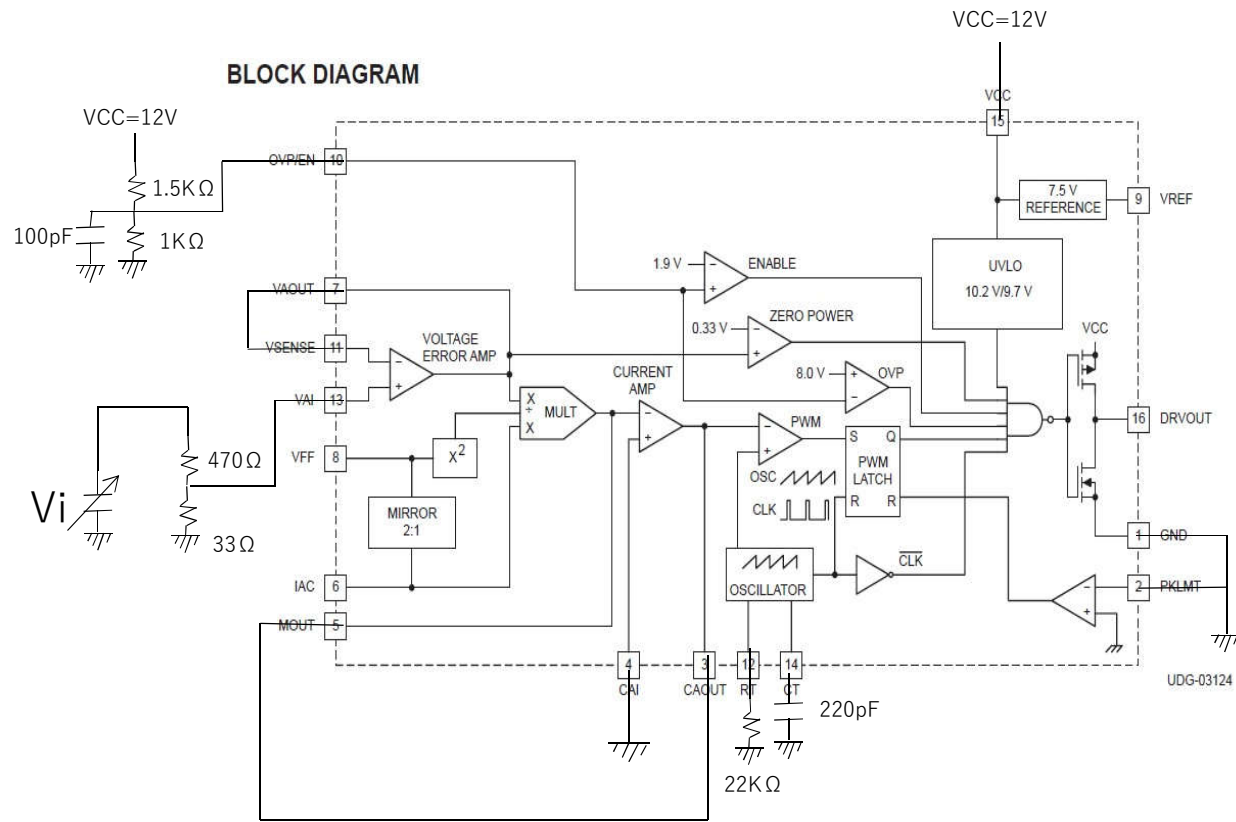

Figure 1

sample	Vai_pin voltage	
	OFF→ON	ON→OFF
OK1	0.588	0.584
OK2	0.582	0.578
OK3	0.594	0.585
NG1	0	0
NG2	0	0
NG3	0	0

Table 1