

BACKLIGHT POWER

202241112 - Rai Modify v0.3 for -301/302/303
 12-022637-01 change to 120000385-001
 REV: 1

4/12 Modify For V0.2
 DEL C14, C15 33uF/100V
 CHANGE C16 from 33uF/100V to 47uF/80V

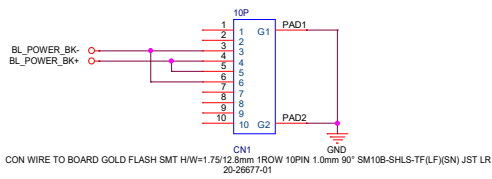
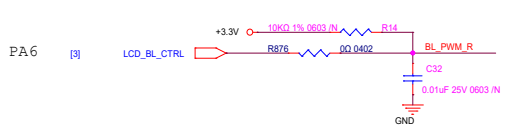
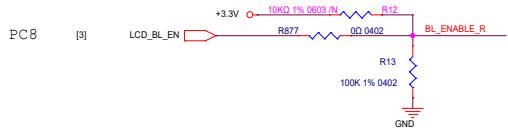
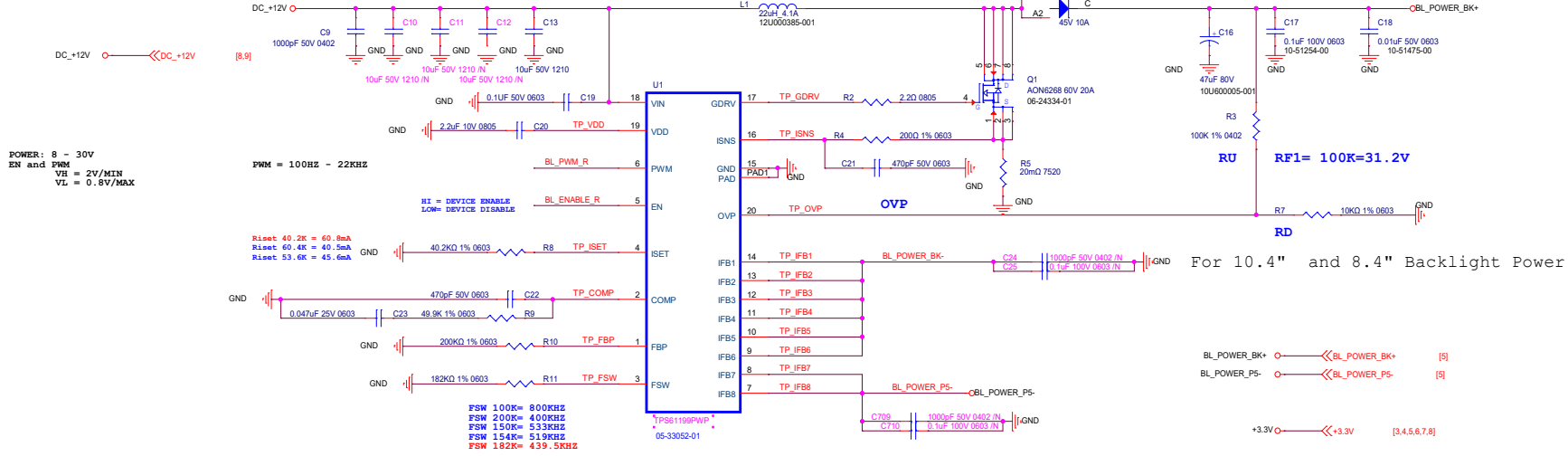

- 10.4 panel backlight define
- 1 - NC
 - 2 - NC
 - 3 - VLSS (K1) : BACKLIGHT CATHODE K1
 - 4 - VLSS (A1) : BACKLIGHT ANODE A1
 - 5 - VLSS (A2) : BACKLIGHT ANODE A2
 - 6 - VLSS (K2) : BACKLIGHT CATHODE K2

