

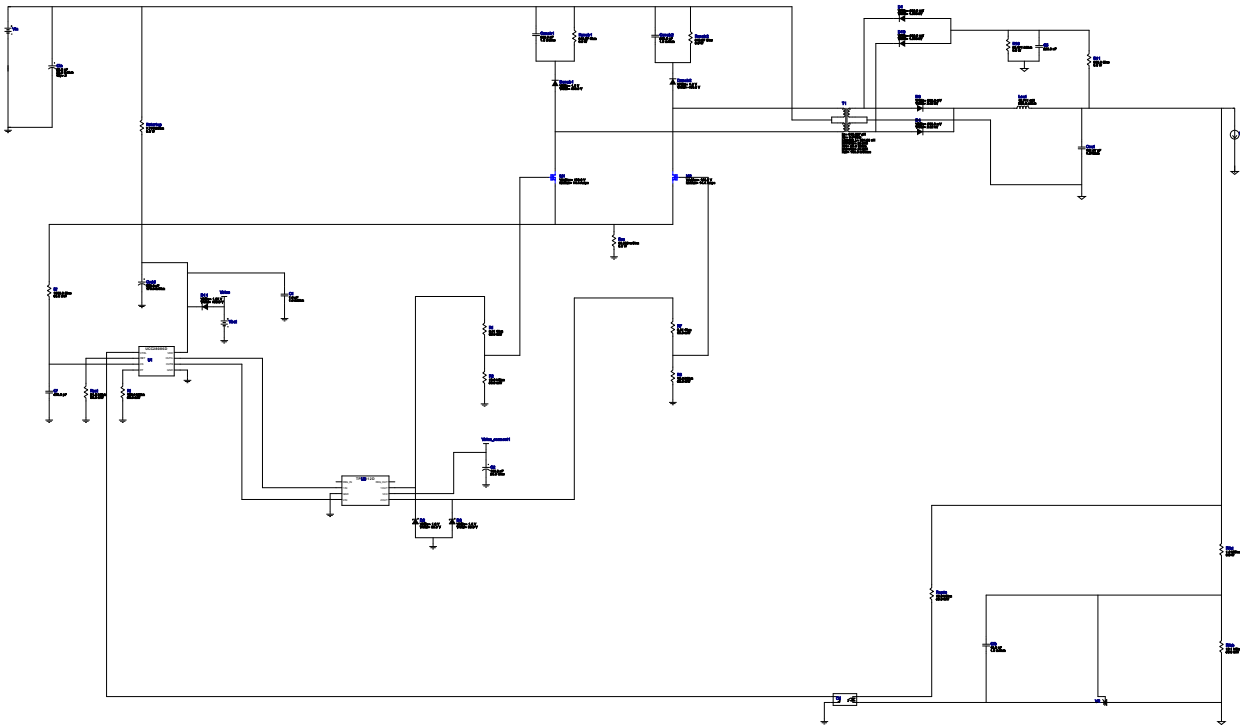















WEBENCH® Design Report

 Design : 135 UCC28086D
 UCC28086D 18V-36V to 3.30V @ 15A

Electrical BOM

Name	Manufacturer	Part Number	Properties	Qty	Price	Footprint
C1	Taiyo Yuden	GMK212B7105KG-T Series= X7R	Cap= 1.0 uF ESR= 1.0 mOhm VDC= 35.0 V IRMS= 0.0 A	1	\$0.03	0805 7 mm ²
C2	Vishay-Sprague	293D104X9035A2TE3 Series= 293D	Cap= 100.0 nF ESR= 20.0 Ohm VDC= 35.0 V IRMS= 60.0 mA	1	\$0.09	3216-18 11 mm ²
C5	CUSTOM	CUSTOM Series= ?	Cap= 220.0 nF VDC= 1.93939 kV IRMS= 0.0 A	1	NA	CUSTOM 0 mm ²
Cf	AVX	04025A471JAT2A Series= C0G/NP0	Cap= 470.0 pF VDC= 50.0 V IRMS= 0.0 A	1	\$0.01	0402 3 mm ²

Name	Manufacturer	Part Number	Properties	Qty	Price	Footprint
Cfb	MuRata	GRM033R70J103KA01D Series= X7R	Cap= 10.0 nF ESR= 1.0 mOhm VDC= 6.3 V IRMS= 0.0 A	1	\$0.01	 0201 2 mm ²
Cin	Panasonic	35SVPF82M Series= SVPF	Cap= 82.0 uF ESR= 20.0 mOhm VDC= 35.0 V IRMS= 4.0 A	2	\$0.63	 CAPSMT_62_E12 106 mm ²
Cout	CUSTOM	CUSTOM Series= ?	Cap= 161.07 nF ESR= 1.0 fOhm VDC= 625.0 V IRMS= 31.492 mA	1	NA	CUSTOM 0 mm ²
Csub1	MuRata	GRM21AR72A334KAC5L Series= X7R	Cap= 330.0 nF ESR= 1.0 mOhm VDC= 100.0 V IRMS= 0.0 A	1	\$0.11	 0805 7 mm ²
Csub2	MuRata	GRM21AR72A334KAC5L Series= X7R	Cap= 330.0 nF ESR= 1.0 mOhm VDC= 100.0 V IRMS= 0.0 A	1	\$0.11	 0805 7 mm ²
Cvdd	Nichicon	UUD1E221MNL1GS Series= uD	Cap= 220.0 uF ESR= 170.0 mOhm VDC= 25.0 V IRMS= 450.0 mA	1	\$0.17	 SM_RADIAL_8MM 113 mm ²
D1	CUSTOM	CUSTOM	VF@Io= 500.0 mV VRRM= 1.939 kV	1	NA	CUSTOM 0 mm ²
D10	CUSTOM	CUSTOM	VF@Io= 500.0 mV VRRM= 1.939 kV	1	NA	CUSTOM 0 mm ²
D11	Diodes Inc.	1N4148W-7-F	VF@Io= 1.25 V VRRM= 100.0 V	1	\$0.03	 SOD-123 13 mm ²
D2	SMC Diode Solutions	BAT54WSTR	VF@Io= 1.0 V VRRM= 30.0 V	1	\$0.02	 SOD-323 9 mm ²
D3	CUSTOM	CUSTOM	VF@Io= 500.0 mV VRRM= 2.02 kV	1	NA	CUSTOM 0 mm ²
D4	CUSTOM	CUSTOM	VF@Io= 500.0 mV VRRM= 2.02 kV	1	NA	CUSTOM 0 mm ²
D8	SMC Diode Solutions	BAT54WSTR	VF@Io= 1.0 V VRRM= 30.0 V	1	\$0.02	 SOD-323 9 mm ²
Dsub1	SMC Diode Solutions	UF4004TA	VF@Io= 1.0 V VRRM= 400.0 V	1	\$0.22	 DO-41 43 mm ²
Dsub2	SMC Diode Solutions	UF4004TA	VF@Io= 1.0 V VRRM= 400.0 V	1	\$0.22	 DO-41 43 mm ²
Lout	CUSTOM	CUSTOM	L= 12.711 mH 500.0 uOhm	1	NA	CUSTOM 0 mm ²
M1	Texas Instruments	CSD19538Q2	VdsMax= 100.0 V IdsMax= 14.4 Amps	1	\$0.15	 DQK0006C 9 mm ²
M2	Texas Instruments	CSD19538Q2	VdsMax= 100.0 V IdsMax= 14.4 Amps	1	\$0.15	 DQK0006C 9 mm ²
O1	Fairchild Semiconductor	FOD817A	Optocoupler	1	\$0.11	 DIP-4 71 mm ²
R1	Vishay-Dale	CRCW04023R01FKED Series= CRCW..e3	Res= 3.01 Ohm Power= 63.0 mW Tolerance= 1.0%	1	\$0.01	 0402 3 mm ²
R10	CUSTOM	CUSTOM Series= ?	Res= 88.171 kOhm Power= 0.0 W Tolerance= 0.0%	1	NA	CUSTOM 0 mm ²

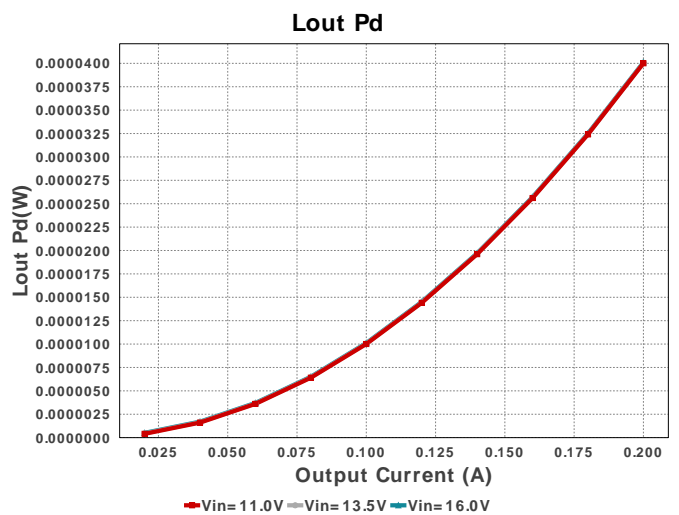
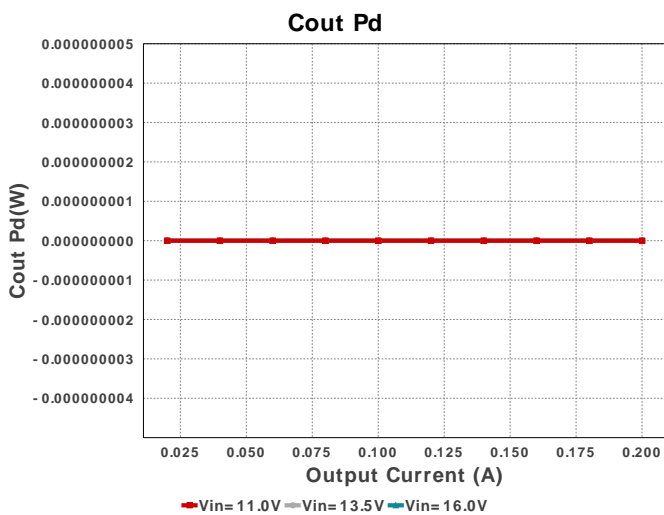
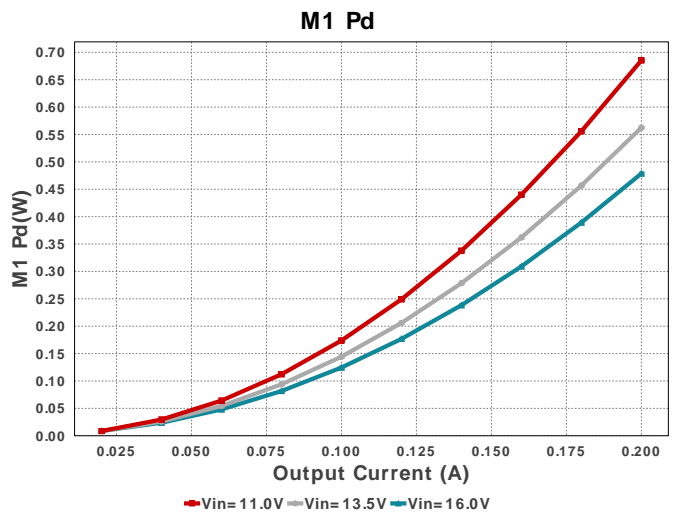
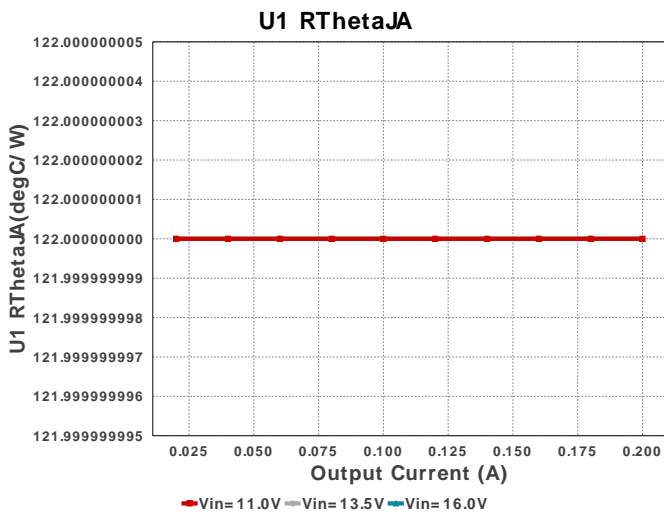
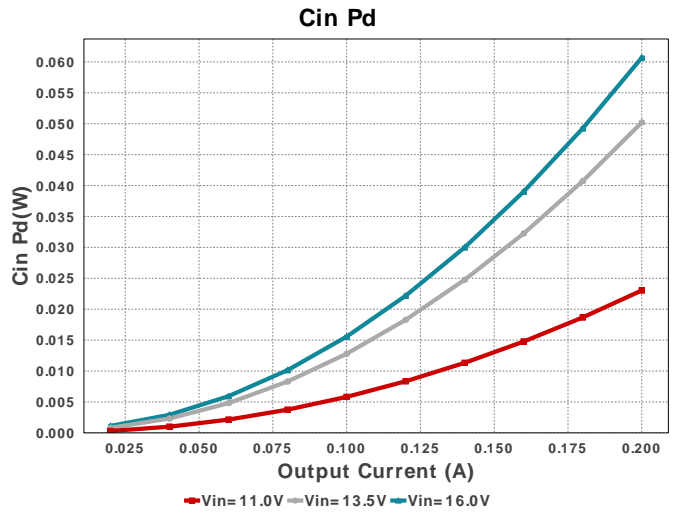
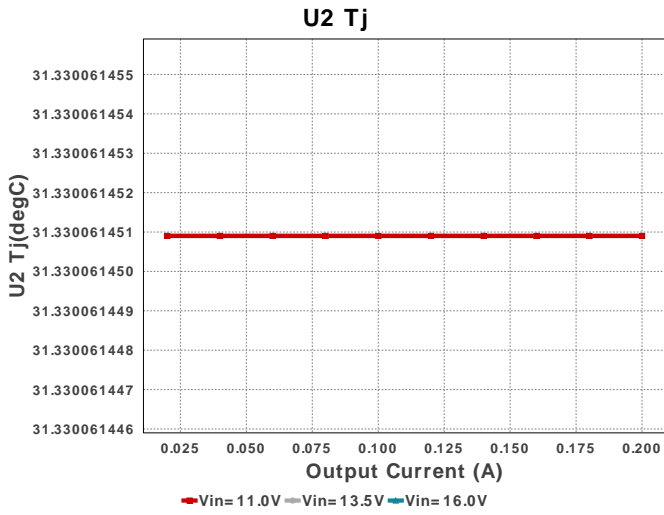
Name	Manufacturer	Part Number	Properties	Qty	Price	Footprint
R11	CUSTOM	CUSTOM Series= ?	Res= 800.0 Ohm Power= 0.0 W Tolerance= 0.0%	1	NA	CUSTOM 0 mm ²
R2	Yageo	RC0201FR-0710KL Series= ?	Res= 10.0 kOhm Power= 50.0 mW Tolerance= 1.0%	1	\$0.01	 0201 2 mm ²
R7	Vishay-Dale	CRCW04023R01FKED Series= CRCW..e3	Res= 3.01 Ohm Power= 63.0 mW Tolerance= 1.0%	1	\$0.01	 0402 3 mm ²
R8	Yageo	RC0201FR-0710KL Series= ?	Res= 10.0 kOhm Power= 50.0 mW Tolerance= 1.0%	1	\$0.01	 0201 2 mm ²
Rcs	CUSTOM	CUSTOM Series= ?	Res= 69.332 mOhm Power= 0.0 W Tolerance= 0.0%	1	NA	CUSTOM 0 mm ²
Rf	Vishay-Dale	CRCW04021K00FKED Series= CRCW..e3	Res= 1000.0 Ohm Power= 63.0 mW Tolerance= 1.0%	1	\$0.01	 0402 3 mm ²
Rfbb	Yageo	RC0201FR-0712K1L Series= ?	Res= 12.1 kOhm Power= 50.0 mW Tolerance= 1.0%	1	\$0.01	 0201 2 mm ²
Rfbt	CUSTOM	CUSTOM Series= ?	Res= 1.2 MOhm Power= 0.0 W Tolerance= 0.0%	1	NA	CUSTOM 0 mm ²
Ropto	Yageo	RC0201FR-0710KL Series= ?	Res= 10.0 kOhm Power= 50.0 mW Tolerance= 1.0%	1	\$0.01	 0201 2 mm ²
Rset	Vishay-Dale	CRCW040221K0FKED Series= CRCW..e3	Res= 21.0 kOhm Power= 63.0 mW Tolerance= 1.0%	1	\$0.01	 0402 3 mm ²
Rsub1	CUSTOM	CUSTOM Series= ?	Res= 640.27 Ohm Power= 0.0 W Tolerance= 0.0%	1	NA	CUSTOM 0 mm ²
Rsub2	CUSTOM	CUSTOM Series= ?	Res= 640.27 Ohm Power= 0.0 W Tolerance= 0.0%	1	NA	CUSTOM 0 mm ²
Rstartup	CUSTOM	CUSTOM Series= ?	Res= 7.776 kOhm Power= 0.0 W Tolerance= 0.0%	1	NA	CUSTOM 0 mm ²
Rt	Yageo	RC0201FR-07162KL Series= ?	Res= 162.0 kOhm Power= 50.0 mW Tolerance= 1.0%	1	\$0.01	 0201 2 mm ²
T1	CUSTOM	CUSTOM	Lp= 549.527 µH Rp= 0.0 Ohm Leakage_L= 824.29 nH Ns1toNp= 25.253 Rs1= 25.0 Ohms Ns2toNp= 25.253 Rs2= 100.0 mOhms	1	NA	CUSTOM 0 mm ²
U1	Texas Instruments	UCC28086D	Switcher	1	\$1.24	 0 mm ²
U2	unknown		unknown		NA	 0 mm ²
VR	Texas Instruments	TL431IDBVR	Voltage References	1	\$0.07	 R-PDSO-G3 16 mm ²

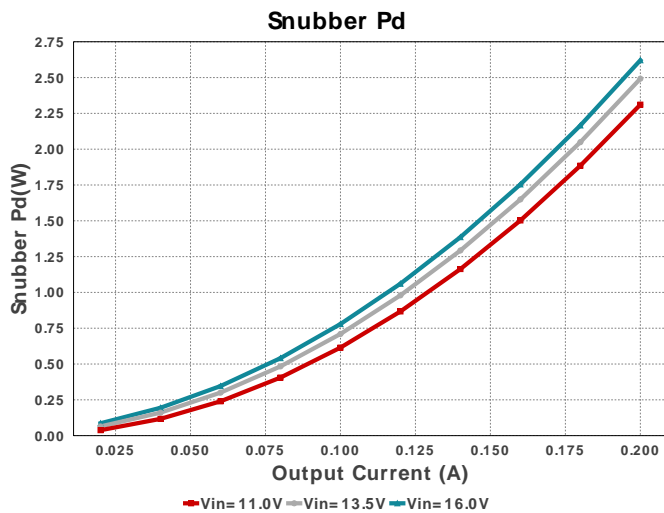
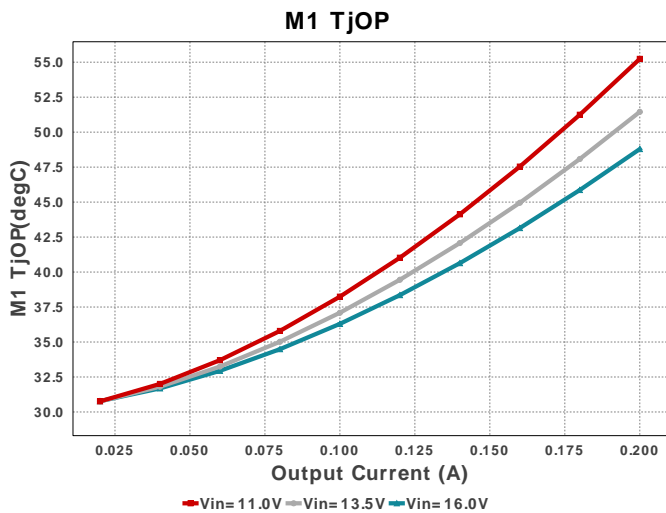
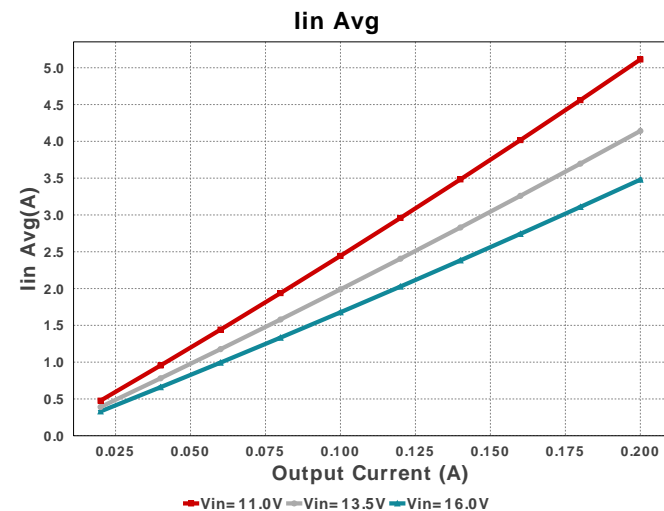
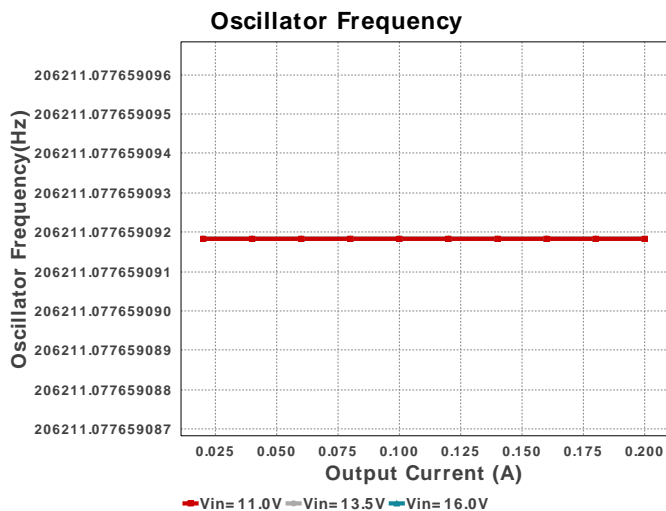
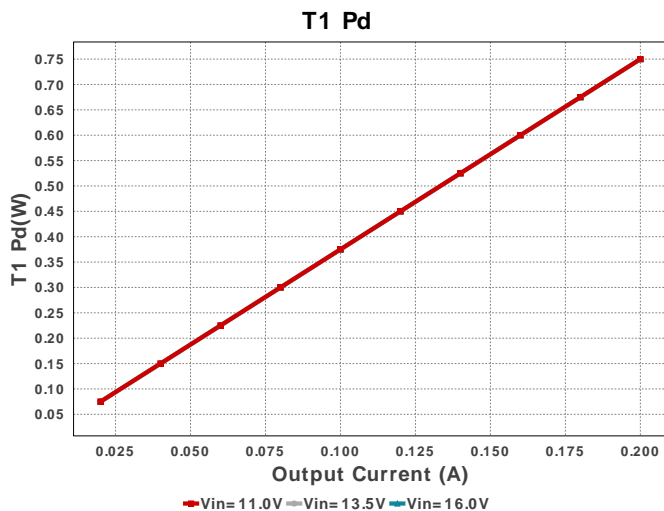
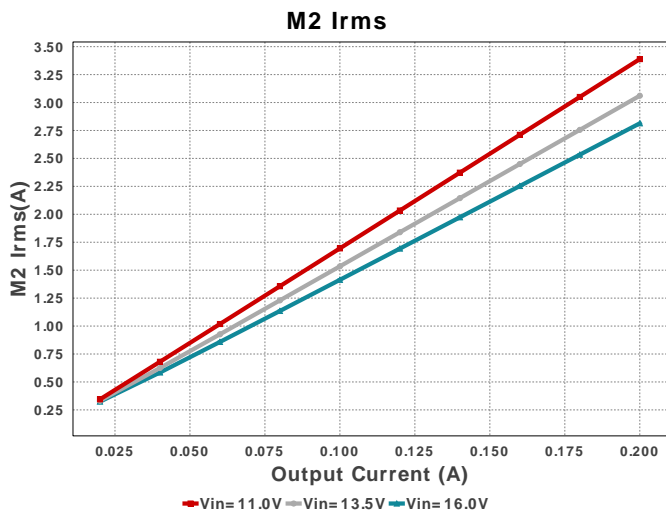



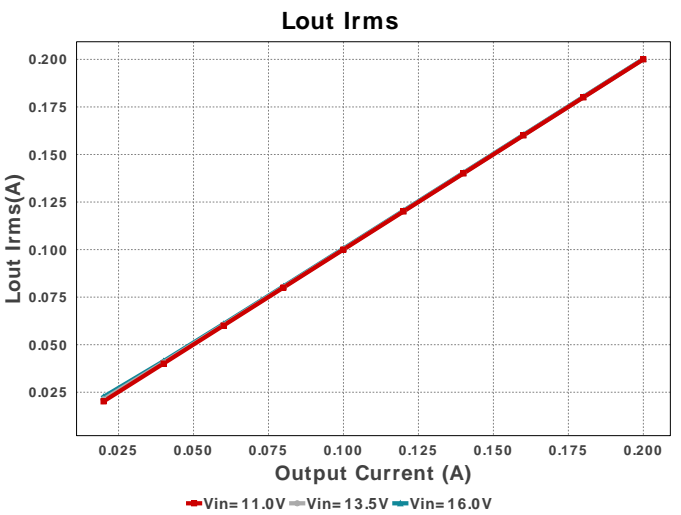
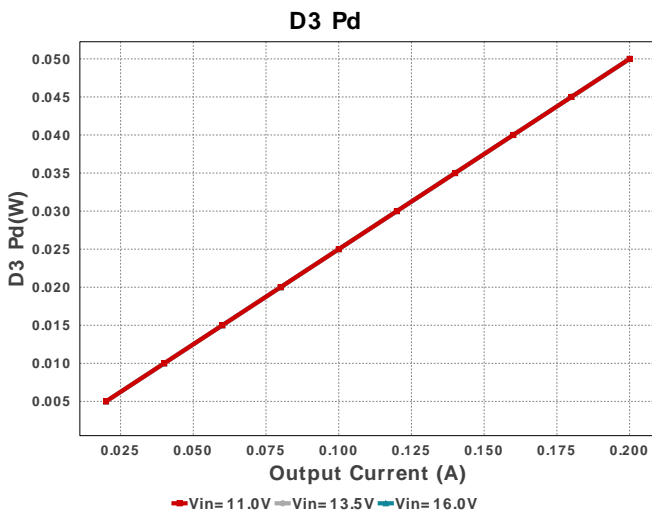
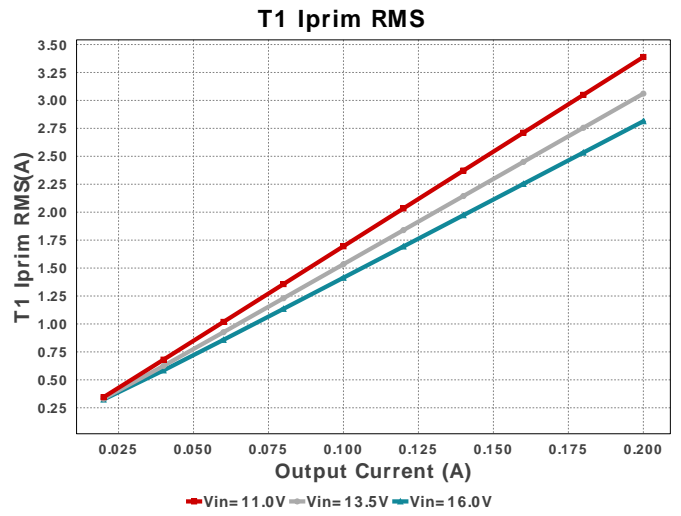
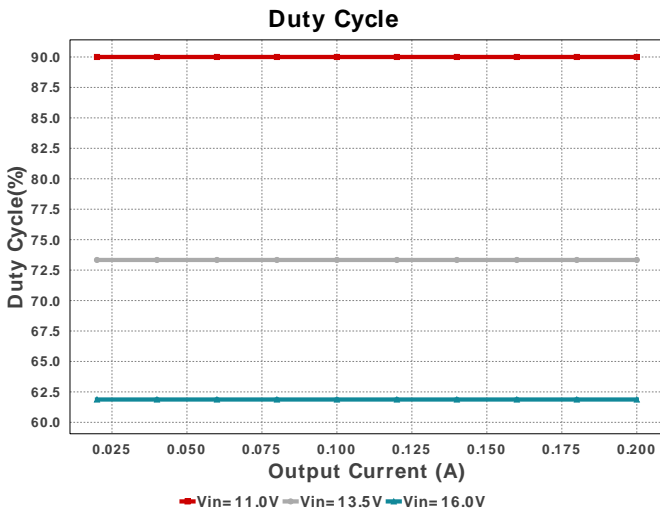
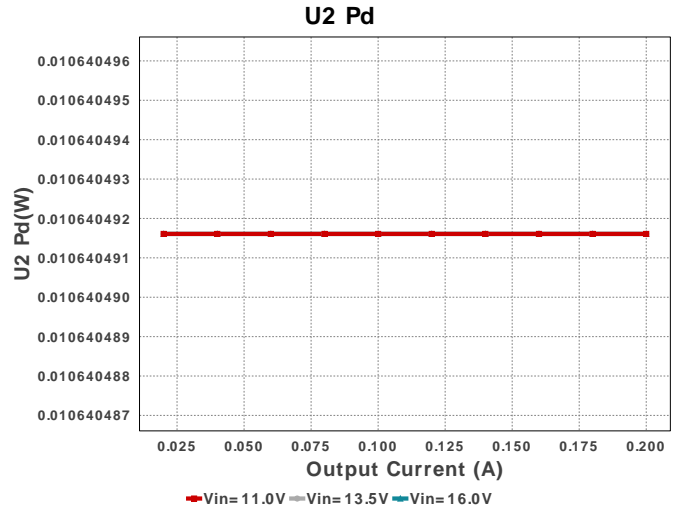
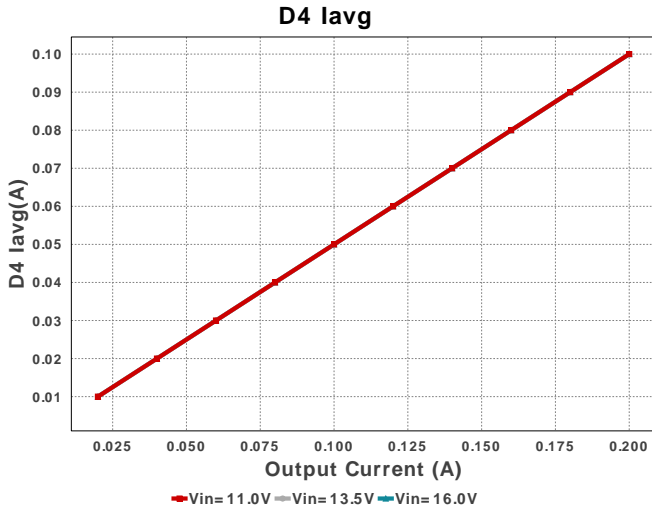

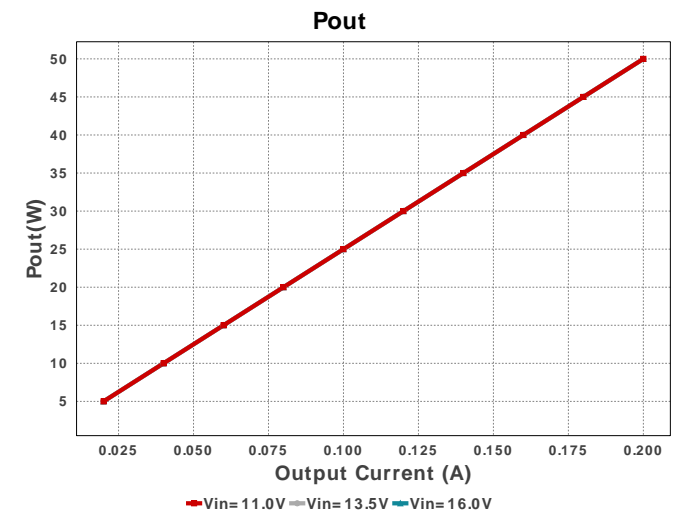
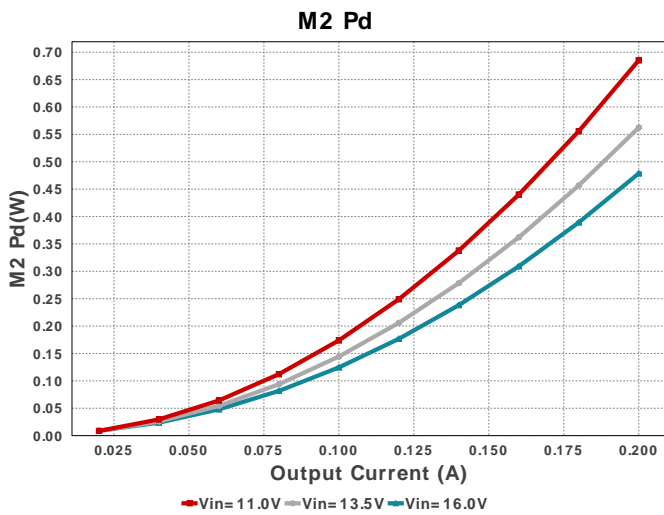
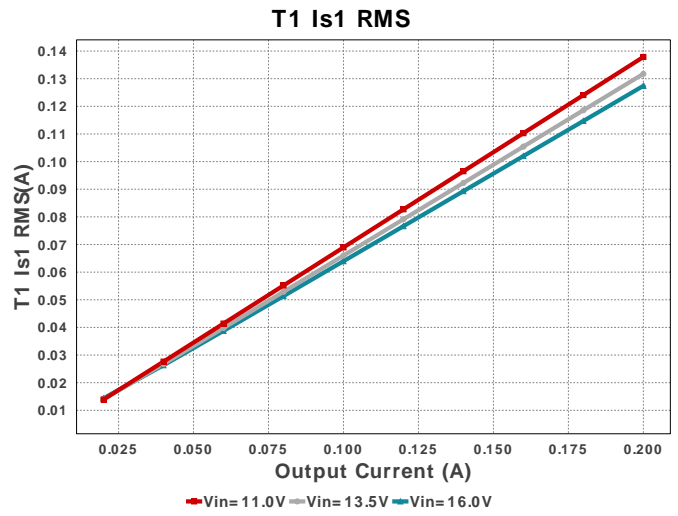
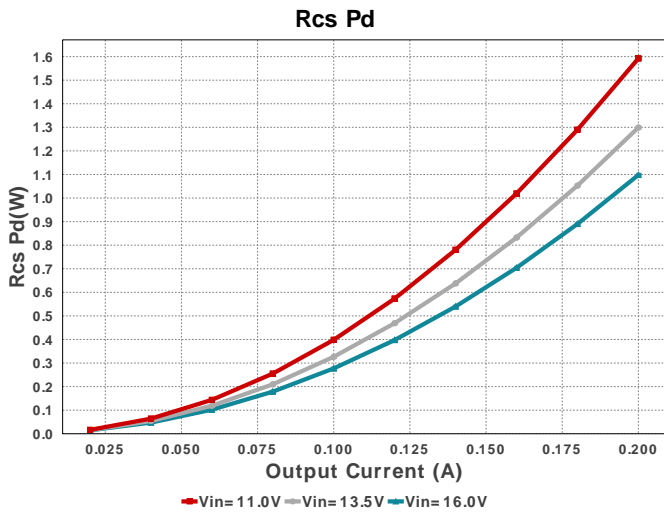
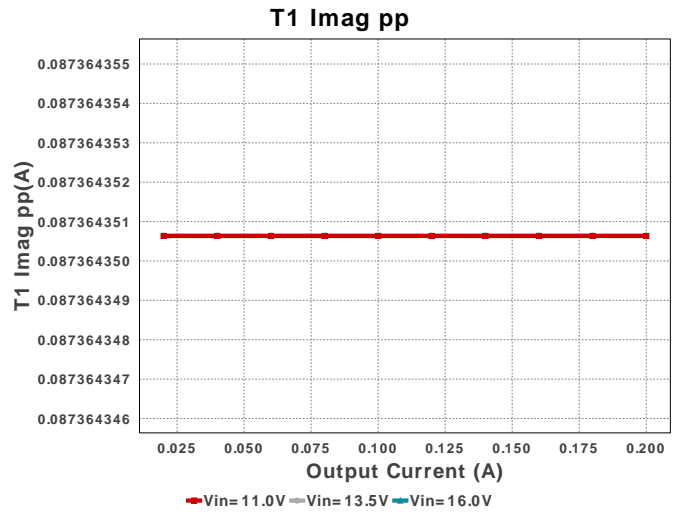
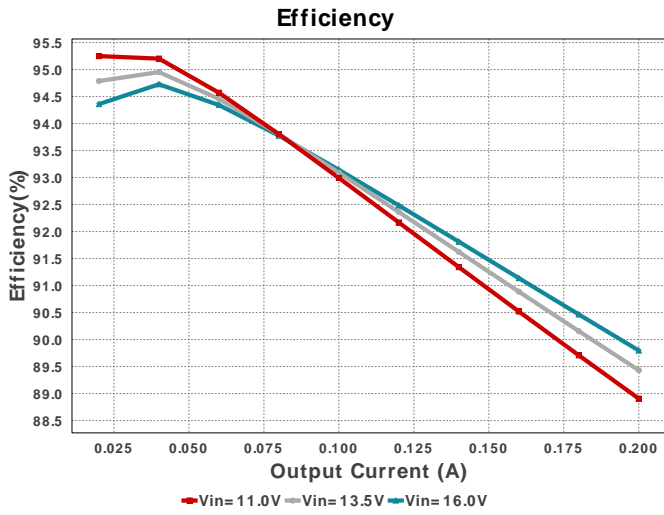

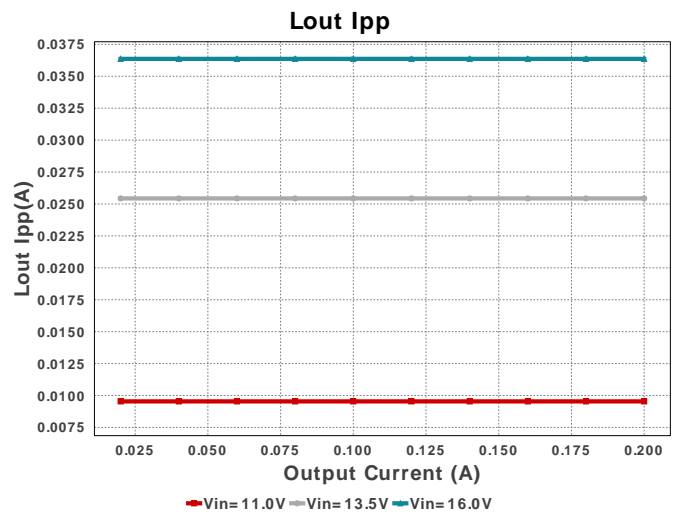
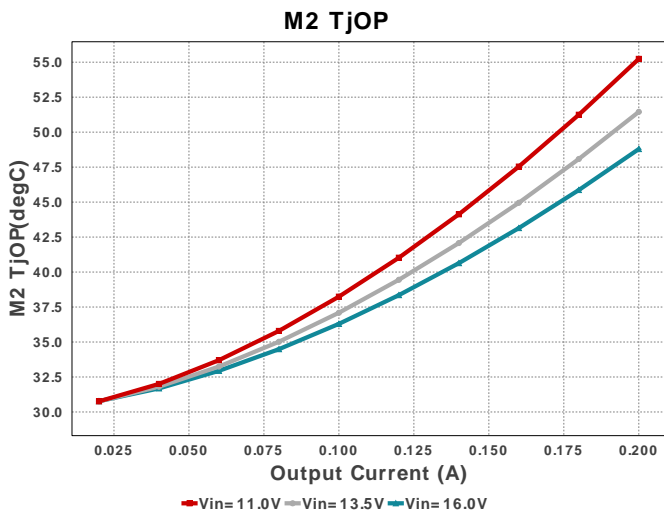
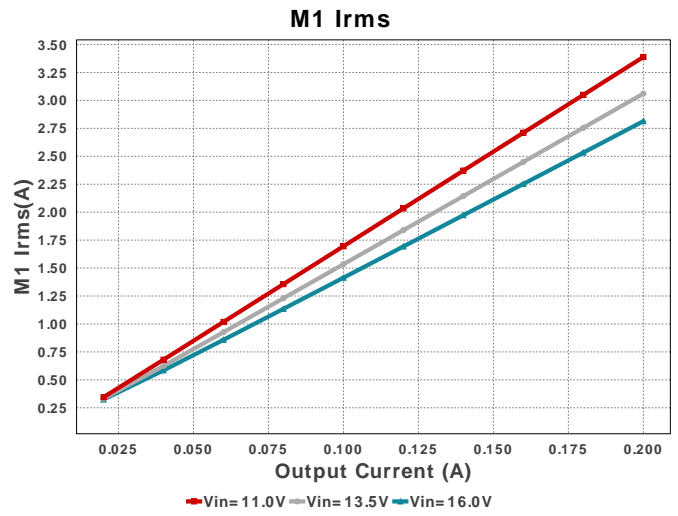
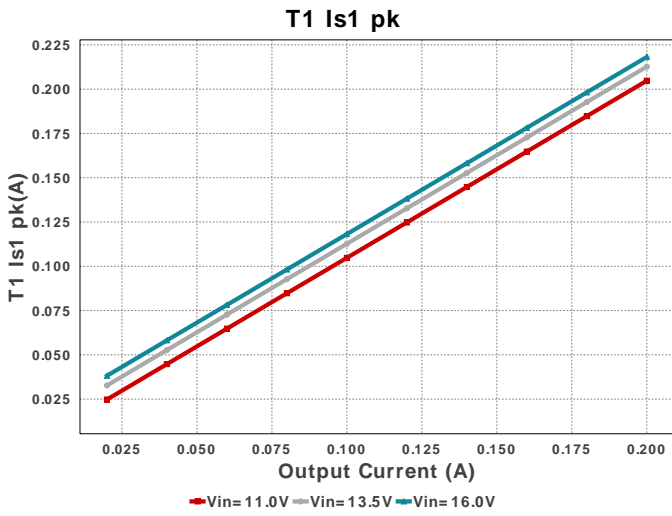
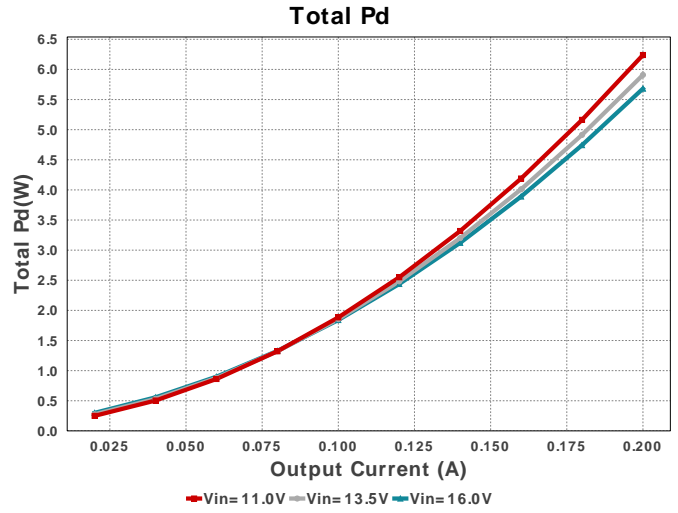
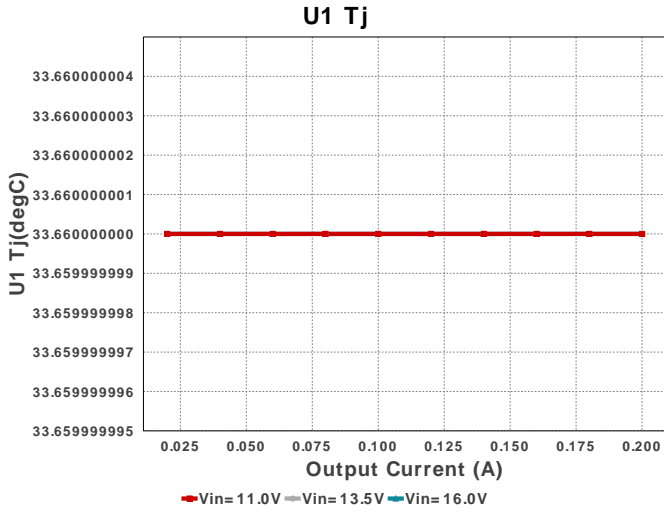

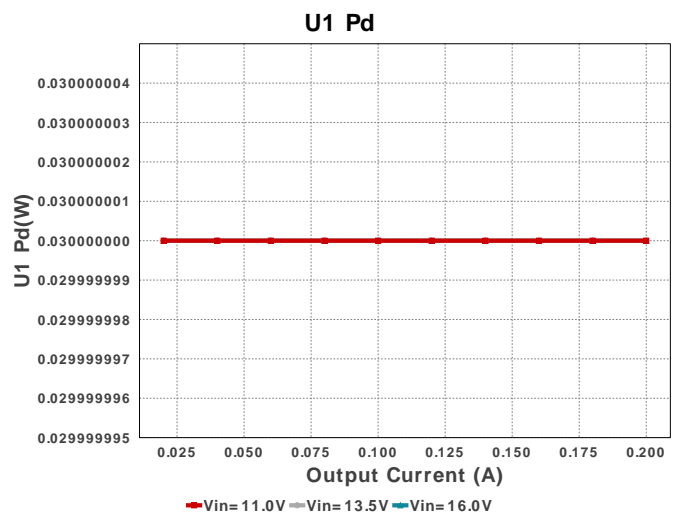
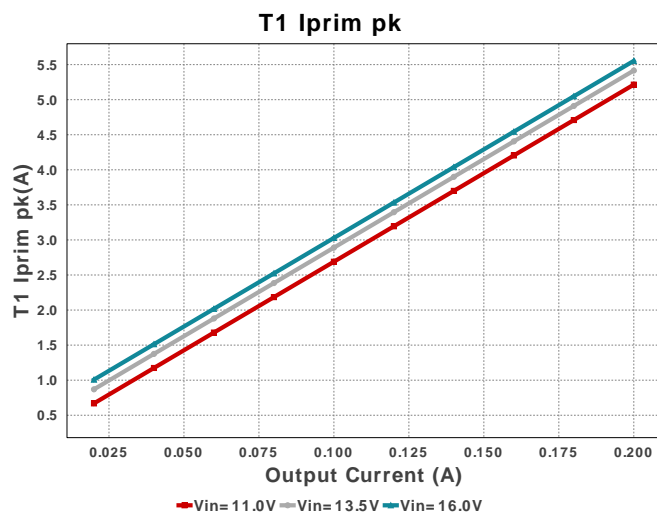
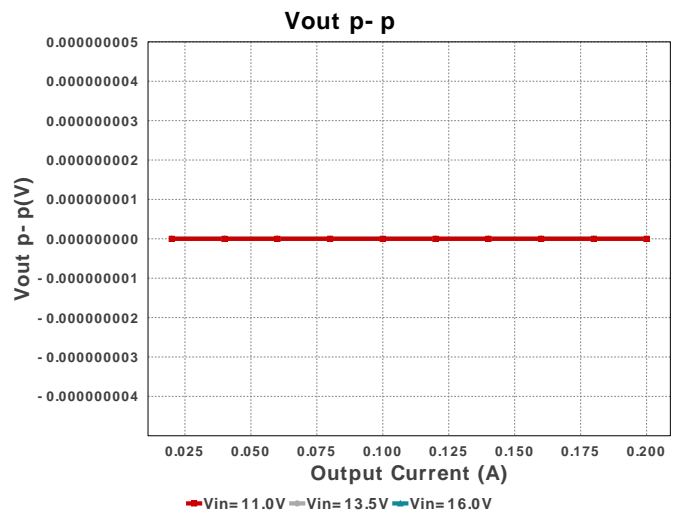
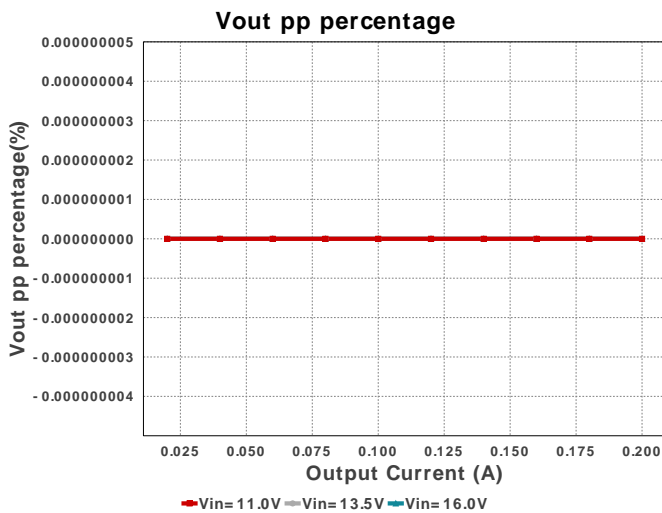
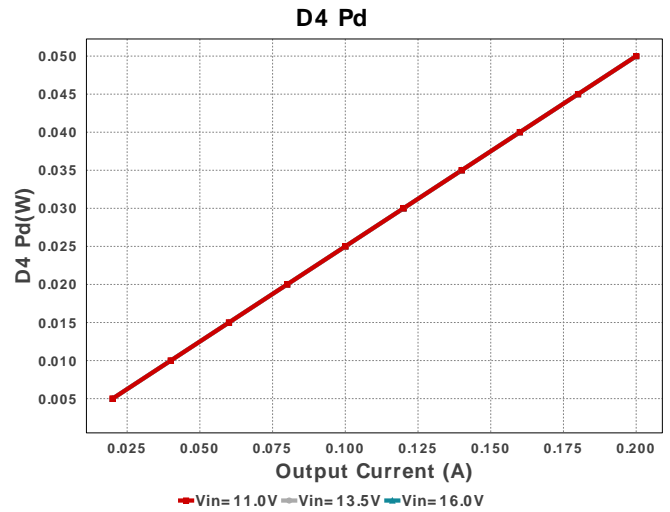
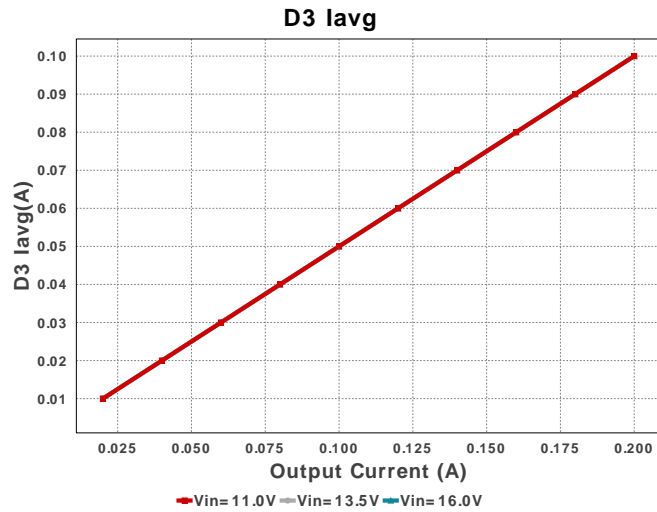

Operating Values

#	Name	Value	Category	Description
1.	Cin Pd	23.037 mW	Capacitor	Input capacitor power dissipation
2.	Cout Pd	0.0 fW	Capacitor	Output capacitor power dissipation
3.	D3 Iavg	100.0 mA	Current	Average current through D3
4.	D4 Iavg	100.0 mA	Current	Average current through D4
5.	Lout Irms	200.019 mA	Current	Lout ripple current
6.	D4 Pd	50.0 mW	Diode	Average Power Dissipation in the Diode over AC Line Period
7.	Iin Avg	5.113 A	IC	Average input current
8.	U1 RThetaJA	122.0 degC/W	IC	U1 IC junction-to-ambient thermal resistance
9.	Lout Ipp	9.538 mA	Inductor	Peak-to-peak output inductor ripple current
10.	M1 Irms	3.389 A	Mosfet	M1 MOSFET Irms
11.	M1 Pd	685.26 mW	Mosfet	M1 MOSFET total power dissipation

#	Name	Value	Category	Description
12.	M1 TjOP	74.542 degC	Mosfet	M1 MOSFET junction temperature
13.	M2 Irms	3.389 A	Mosfet	M2 MOSFET Irms
14.	M2 Pd	685.26 mW	Mosfet	M2 MOSFET total power dissipation
15.	M2 TjOP	74.542 degC	Mosfet	M2 MOSFET junction temperature
16.	Oscillator Frequency	206.211 kHz	Op Point	Oscillator Frequency
17.	Cin Pd	23.037 mW	Power	Input capacitor power dissipation
18.	Cout Pd	0.0 fW	Power	Output capacitor power dissipation
19.	D3 Pd	50.0 mW	Power	
20.	D4 Pd	50.0 mW	Power	Average Power Dissipation in the Diode over AC Line Period
21.	Lout Pd	40.008 μW	Power	Lout power dissipation
22.	M1 Pd	685.26 mW	Power	M1 MOSFET total power dissipation
23.	M2 Pd	685.26 mW	Power	M2 MOSFET total power dissipation
24.	Rcs Pd	1.592 W	Power	Power Dissipation in Current Sense Resistors
25.	Snubber Pd	2.311 W	Power	Snubber Power Dissipation
26.	T1 Pd	750.0 mW	Power	Estimated Losses in Transformer
27.	Total Pd	6.239 W	Power	Total Power Dissipation
28.	U1 Pd	30.0 mW	Power	U1 Power Dissipation
29.	U2 Pd	10.64 mW	Power	U2 Power Dissipation
30.	Rcs Pd	1.592 W	Resistor	Power Dissipation in Current Sense Resistors
31.	BOM Count	44	System	Total Design BOM count
32.	Duty Cycle	90.0 %	System Information	Duty cycle
33.	Efficiency	88.906 %	System Information	Steady state efficiency
34.	FootPrint	1.027 k mm ²	System Information	Total Foot Print Area of BOM components
35.	Iout	200.0 mA	System Information	Iout operating point
36.	Mode	CCM	System Information	Conduction Mode
37.	Pout	50.0 W	System Information	Total output power
38.	Total BOM	NA	System Information	Total BOM Cost
39.	U1 Tj	33.66 degC	System Information	U1 junction temperature
40.	U2 Tj	31.33 degC	System Information	U2 junction temperature
41.	Vin	11.0 V	System Information	Vin operating point
42.	Vout Actual	250.0 V	System Information	Operational Output Voltage
43.	Vout Tolerance	1.0 %	System Information	Vout Tolerance based on IC Tolerance (no load) and voltage divider resistors if applicable
44.	Vout p-p	0.01 fV	System Information	Peak-to-peak output ripple voltage
45.	Vout pp percentage	0.004 f%	System Information	Output Voltage ripple percentage
46.	T1 Imag pp	87.364 mA	Transformer	Transformer peak to peak magnetising current
47.	T1 Iprim RMS	3.389 A	Transformer	Transformer Primary RMS Current
48.	T1 Iprim pk	5.215 A	Transformer	Transformer Primary Peak Current
49.	T1 Is1 RMS	137.854 mA	Transformer	Transformer Secondary1 RMS Current
50.	T1 Is1 pk	204.769 mA	Transformer	Transformer Secondary1 Peak Current
51.	T1 Pd	750.0 mW	Transformer	Estimated Losses in Transformer

Design Inputs

Name	Value	Description
Iout	200.0 m	Maximum Output Current
VinMax	16.0	Maximum input voltage
VinMin	11.0	Minimum input voltage
Vout	250.0	Output Voltage
base_pn	UCC28086	Base Product Number
source	DC	Input Source Type
Ta	30.0	Ambient temperature
UserFsw	200.0 k	Customer Selected Frequency

WEBENCH® Assembly

Component Testing

Some published data on components in datasheets such as Capacitor ESR and Inductor DC resistance is based on conservative values that will guarantee that the components always exceed the specification. For design purposes it is usually better to work with typical values. Since this data is not always available it is a good practice to measure the Capacitance and ESR values of C_{in} and C_{out} , and the inductance and DC resistance of L1 before assembly of the board. Any large discrepancies in values should be electrically simulated in WEBENCH to check for instabilities and thermally simulated in WebTHERM to make sure critical temperatures are not exceeded.

Soldering Component to Board

If board assembly is done in house it is best to tack down one terminal of a component on the board then solder the other terminal. For surface mount parts with large tabs, such as the DPAK, the tab on the back of the package should be pre-tinned with solder, then tacked into place by one of the pins. To solder the tab down to the board place the iron down on the board while resting against the tab, heating both surfaces simultaneously. Apply light pressure to the top of the plastic case until the solder flows around the part and the part is flush with the PCB. If the solder is not flowing around the board you may need a higher wattage iron (generally 25W to 30W is enough).

Initial Startup of Circuit

It is best to initially power up the board by setting the input supply voltage to the lowest operating input voltage 11.0V and set the input supply's current limit to zero. With the input supply off connect up the input supply to V_{in} and GND. Connect a digital volt meter and a load if needed to set the minimum load of the design from V_{out} and GND. Turn on the input supply and slowly turn up the current limit on the input supply. If the voltage starts to rise on the input supply continue increasing the input supply current limit while watching the output voltage. If the current increases on the input supply, but the voltage remains near zero, then there may be a short or a component misplaced on the board. Power down the board and visually inspect for solder bridges and recheck the diode and capacitor polarities. Once the power supply circuit is operational then more extensive testing may include full load testing, transient load and line tests to compare with simulation results.

Load Testing

The setup is the same as the initial startup, except that an additional digital voltmeter is connected between V_{in} and GND, a load is connected between V_{out} and GND and a current meter is connected in series between V_{out} and the load. The load must be able to handle at least rated output power + 50% (7.5 watts for this design). Ideally the load is supplied in the form of a variable load test unit. It can also be done in the form of suitably large power resistors. When using an oscilloscope to measure waveforms on the prototype board, the ground leads of the oscilloscope probes should be as short as possible and the area of the loop formed by the ground lead should be kept to a minimum. This will help reduce ground lead inductance and eliminate EMI noise that is not actually present in the circuit.

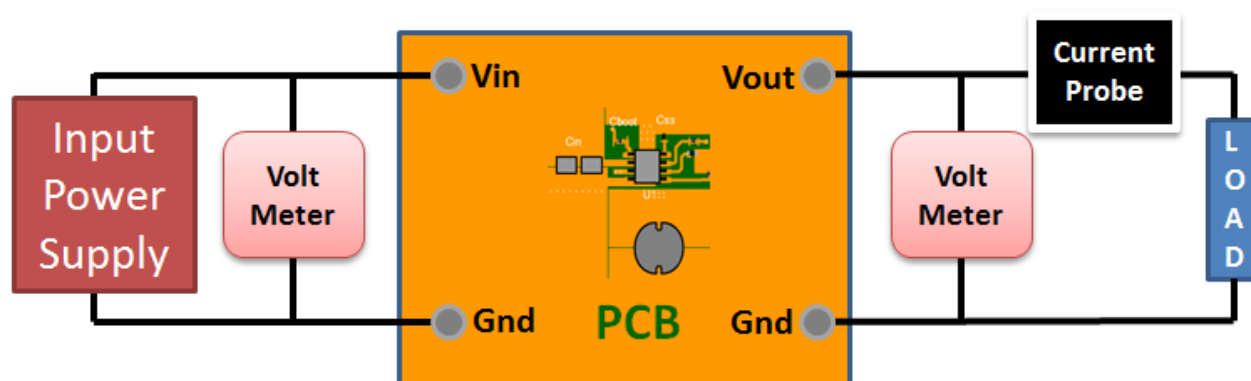

Design Assistance

1. Master key : CE2F1CB87367FF27[v1]
2. **UCC28086** Product Folder : <http://www.ti.com/product/UCC28083> : contains the data sheet and other resources.

Important Notice and Disclaimer

TI provides technical and reliability data (including datasheets), design resources (including reference designs), application or other design advice, web tools, safety information, and other resources AS IS and with all faults, and disclaims all warranties. These resources are intended for skilled developers designing with TI products. You are solely responsible for (1) selecting the appropriate TI products for your application, (2) designing, validating and testing your application, and (3) ensuring your application meets applicable standards, and any other safety, security, or other requirements.

These resources are subject to change without notice. TI grants you permission to use these resources only for development of an application that uses the TI products described in the resource. Other reproduction and display of these resources is prohibited. No license is granted to any other TI intellectual property right or to any third party intellectual property right. TI disclaims responsibility for, and you will fully indemnify TI and its representatives against, any claims, damages, costs, losses, and liabilities arising out of your use of these resources.

Providing these resources does not expand or otherwise alter TI's applicable Terms of Sale or other applicable terms available either on ti.com or provided in conjunction with TI products.