

VinMin = 8.0V
 VinMax = 16.0V
 Vout = 9.0V
 Iout = 3.0A

Device = TPS55288RPMR
 Topology = Buck_Boost
 Created = 2023-06-08 23:27:02.568
 BOM Cost = \$5.23
 BOM Count = 25
 Total Pd = 1.61W

WEBENCH[®] Design Report

Design : 13 TPS55288RPMR
 TPS55288RPMR 8V-16V to 9.00V @ 3A

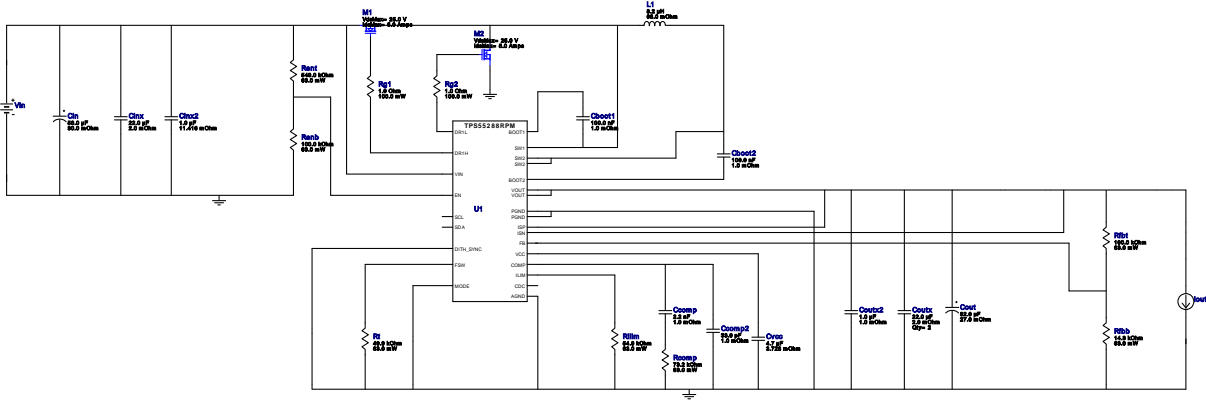

Electrical BOM

Name	Manufacturer	Part Number	Properties	Qty	Price	Footprint
Cboot1	Taiyo Yuden	EMK107B7104KA-T Series= X7R	Cap= 100.0 nF ESR= 1.0 mOhm VDC= 16.0 V IRMS= 0.0 A	1	\$0.01	0603 5 mm ²
Cboot2	Taiyo Yuden	EMK107B7104KA-T Series= X7R	Cap= 100.0 nF ESR= 1.0 mOhm VDC= 16.0 V IRMS= 0.0 A	1	\$0.01	0603 5 mm ²
Ccomp	MuRata	GRM155R71C222KA01D Series= X7R	Cap= 2.2 nF ESR= 1.0 mOhm VDC= 16.0 V IRMS= 0.0 A	1	\$0.01	0402 3 mm ²
Ccomp2	MuRata	GRM1555C1E330JA01D Series= C0G/NP0	Cap= 33.0 pF ESR= 1.0 mOhm VDC= 25.0 V IRMS= 0.0 A	1	\$0.01	0402 3 mm ²
Cin	Panasonic	20SVPF56MX Series= SVPF	Cap= 56.0 uF ESR= 30.0 mOhm VDC= 20.0 V IRMS= 2.8 A	1	\$0.47	 CAPSMT_62_E61 53 mm ²
Cinx	MuRata	GRM32ER61E226KE15L Series= X5R	Cap= 22.0 uF ESR= 2.0 mOhm VDC= 25.0 V IRMS= 3.67 A	1	\$0.23	1210 15 mm ²
Cinx2	TDK	C1005X5R1V105K050BC Series= X5R	Cap= 1.0 uF ESR= 11.416 mOhm VDC= 35.0 V IRMS= 1.483 A	1	\$0.03	0402 3 mm ²
Cout	Panasonic	16SVPF82M Series= SVPF	Cap= 82.0 uF ESR= 27.0 mOhm VDC= 16.0 V IRMS= 3.0 A	1	\$0.47	 CAPSMT_62_E61 53 mm ²
Coutx	MuRata	GRM32ER61E226KE15L Series= X5R	Cap= 22.0 uF ESR= 2.0 mOhm VDC= 25.0 V IRMS= 3.67 A	2	\$0.23	1210 15 mm ²

Name	Manufacturer	Part Number	Properties	Qty	Price	Footprint
Coutx2	Taiyo Yuden	EMK107B7105KA-T Series= X7R	Cap= 1.0 uF ESR= 1.0 mOhm VDC= 16.0 V IRMS= 0.0 A	1	\$0.01	 0603 5 mm ²
Cvcc	TDK	C1608X6S1C475K080AC Series= X6S	Cap= 4.7 uF ESR= 3.728 mOhm VDC= 16.0 V IRMS= 2.69359 A	1	\$0.08	 0603 5 mm ²
L1	Vishay-Dale	IHLP2525CZER8R2M01	L= 8.2 uH 68.0 mOhm	1	\$0.61	 IHLP-2525CZ 75 mm ²
M1	Texas Instruments	CSD16301Q2	VdsMax= 25.0 V IdsMax= 5.0 Amps	1	\$0.11	DQK0006C 9 mm ²
M2	Texas Instruments	CSD16301Q2	VdsMax= 25.0 V IdsMax= 5.0 Amps	1	\$0.11	DQK0006C 9 mm ²
Rcomp	Vishay-Dale	CRCW040273K2FKED Series= CRCW..e3	Res= 73.2 kOhm Power= 63.0 mW Tolerance= 1.0%	1	\$0.01	 0402 3 mm ²
Renb	Vishay-Dale	CRCW0402100KFKED Series= CRCW..e3	Res= 100.0 kOhm Power= 63.0 mW Tolerance= 1.0%	1	\$0.01	 0402 3 mm ²
Rent	Vishay-Dale	CRCW0402549KFKED Series= CRCW..e3	Res= 549.0 kOhm Power= 63.0 mW Tolerance= 1.0%	1	\$0.01	 0402 3 mm ²
Rfbb	Vishay-Dale	CRCW040214K3FKED Series= CRCW..e3	Res= 14.3 kOhm Power= 63.0 mW Tolerance= 1.0%	1	\$0.01	 0402 3 mm ²
Rfbt	Vishay-Dale	CRCW0402100KFKED Series= CRCW..e3	Res= 100.0 kOhm Power= 63.0 mW Tolerance= 1.0%	1	\$0.01	 0402 3 mm ²
Rg1	Vishay-Dale	CRCW06031R00FKEA Series= CRCW..e3	Res= 1.0 Ohm Power= 100.0 mW Tolerance= 1.0%	1	\$0.01	 0603 5 mm ²
Rg2	Vishay-Dale	CRCW06031R00FKEA Series= CRCW..e3	Res= 1.0 Ohm Power= 100.0 mW Tolerance= 1.0%	1	\$0.01	 0603 5 mm ²
Rilim	Vishay-Dale	CRCW040254K9FKED Series= CRCW..e3	Res= 54.9 kOhm Power= 63.0 mW Tolerance= 1.0%	1	\$0.01	 0402 3 mm ²
Rt	Vishay-Dale	CRCW040249K9FKED Series= CRCW..e3	Res= 49.9 kOhm Power= 63.0 mW Tolerance= 1.0%	1	\$0.01	 0402 3 mm ²
U1	Texas Instruments	TPS55288RPMR	Switcher	1	\$2.52	RPM0026A 22 mm ²

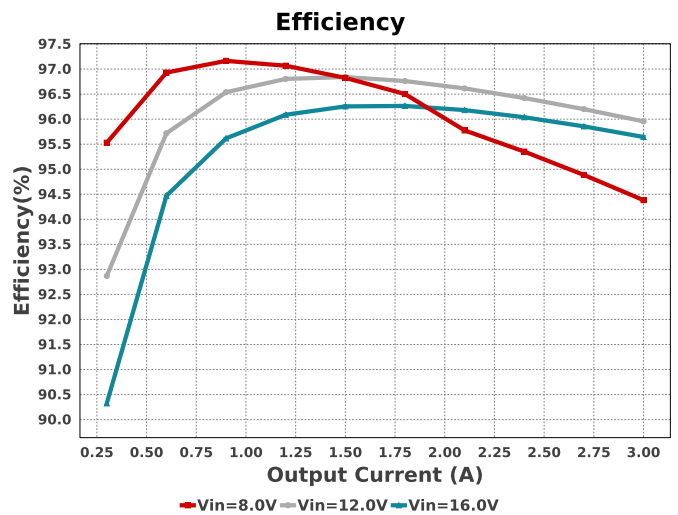
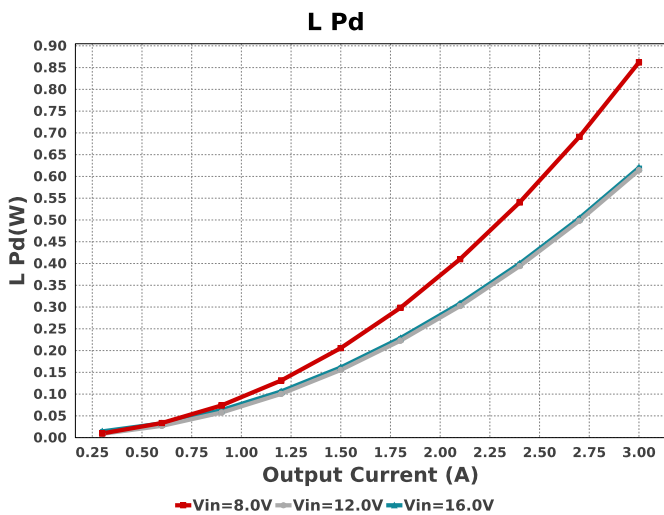
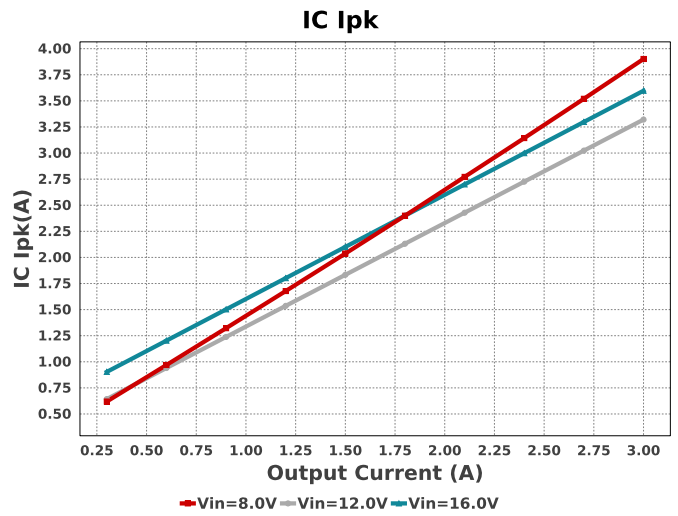
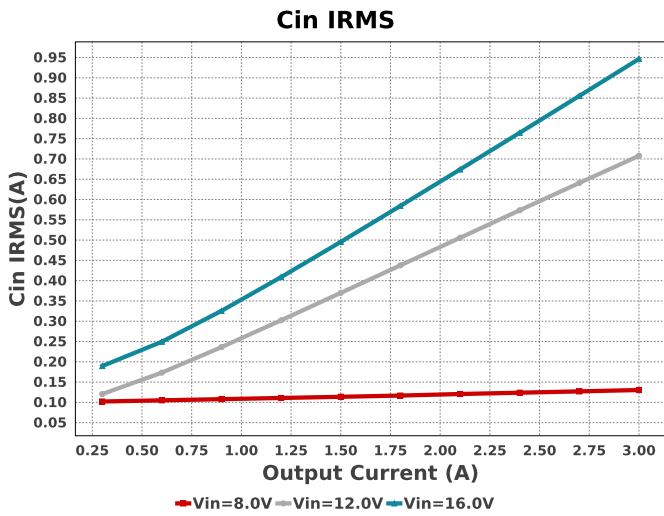
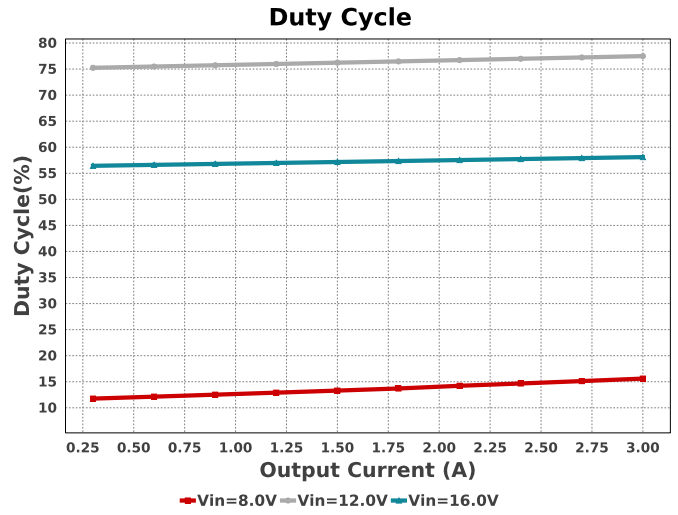
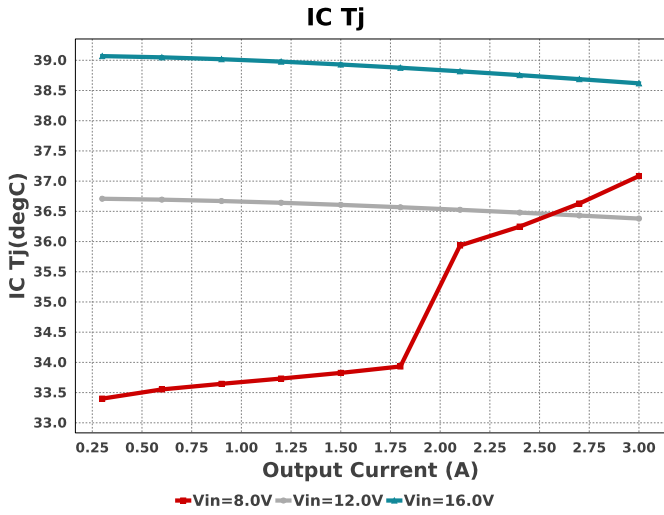

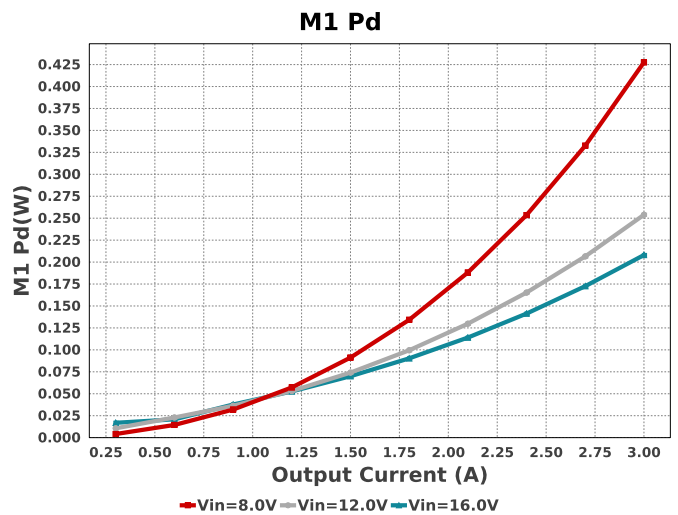
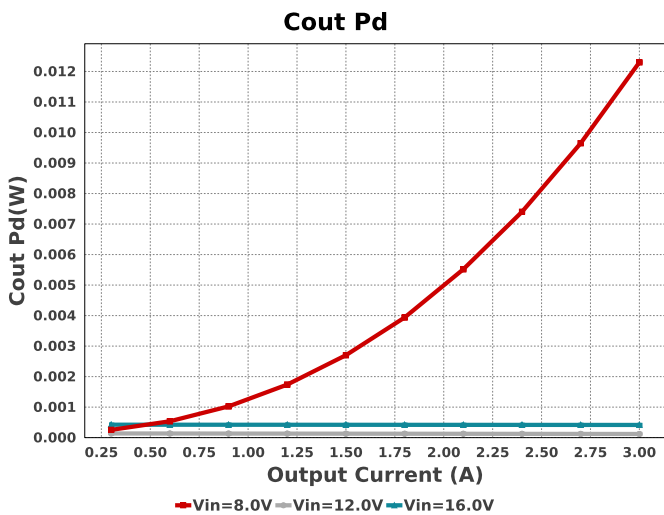
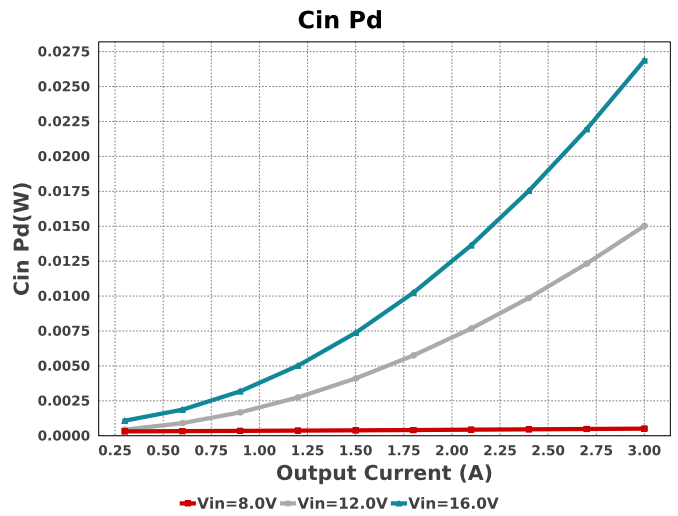
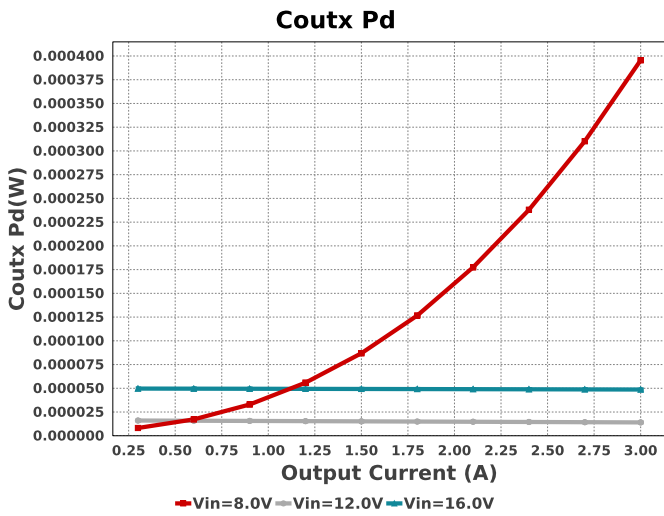
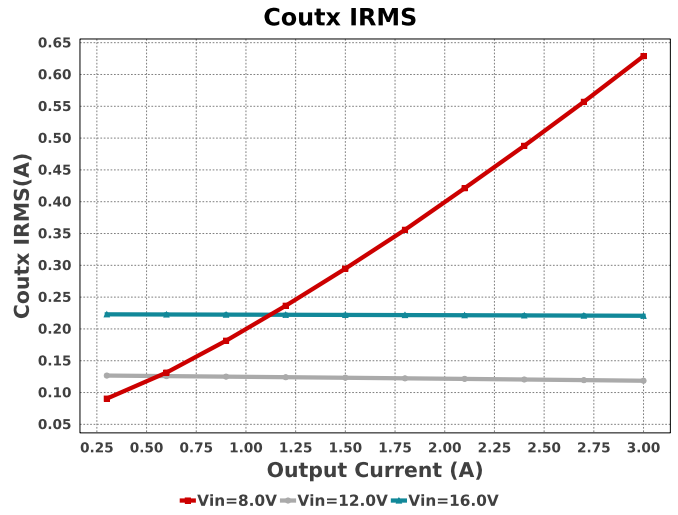
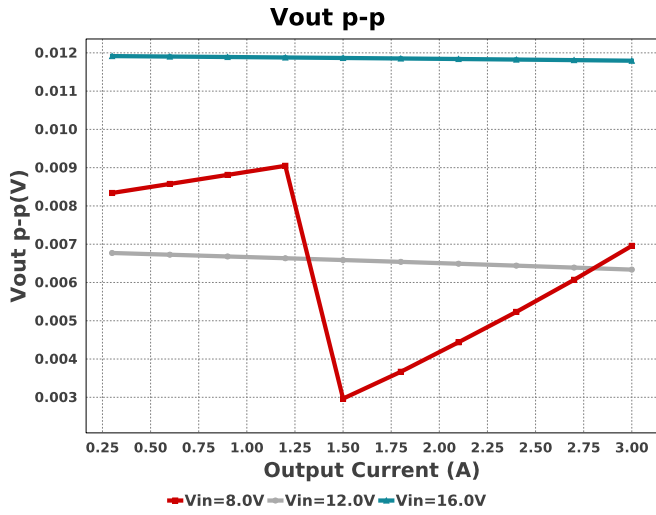

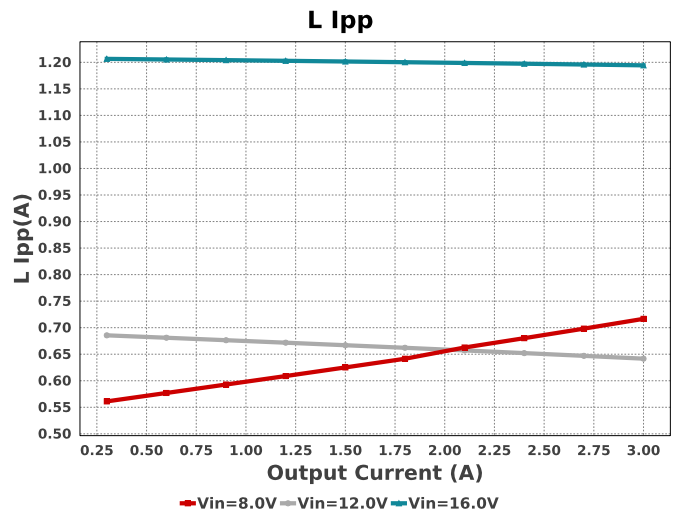
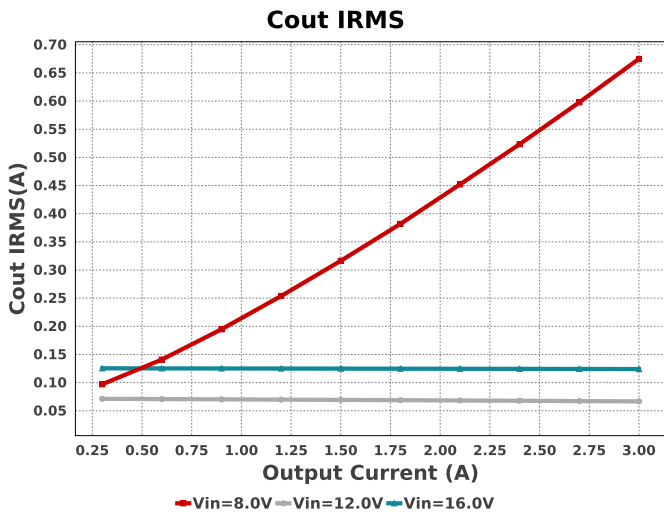
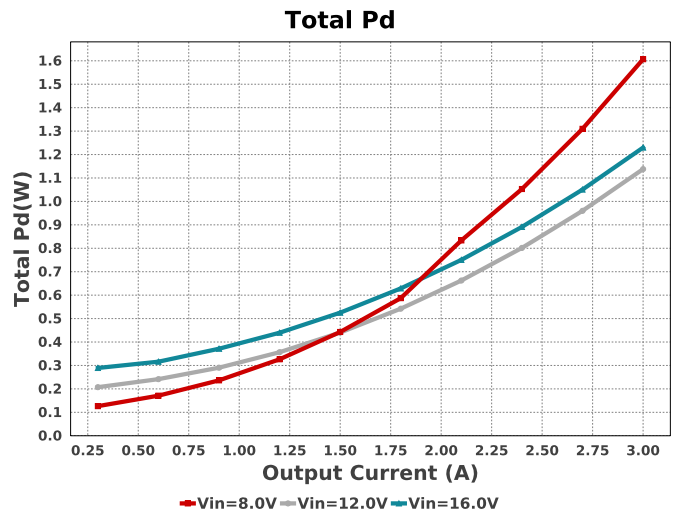
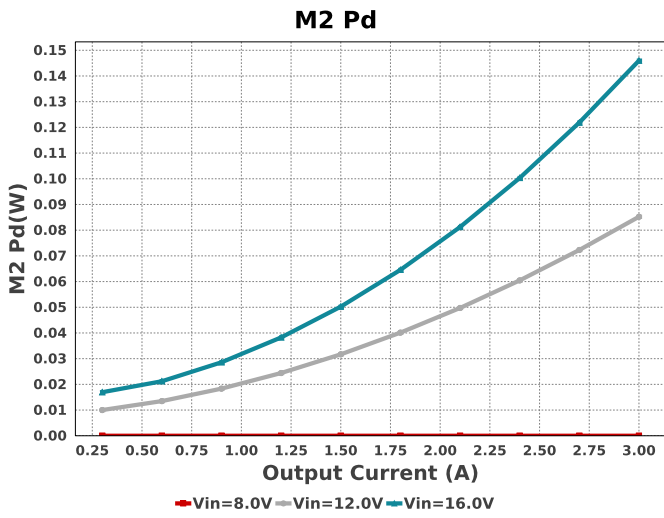
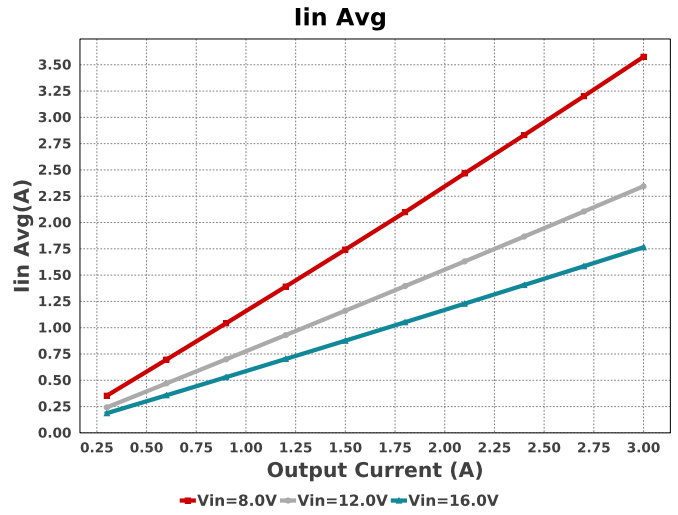
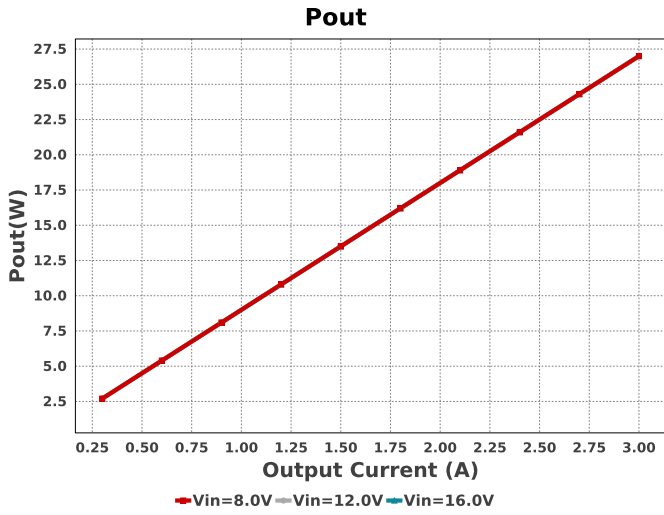

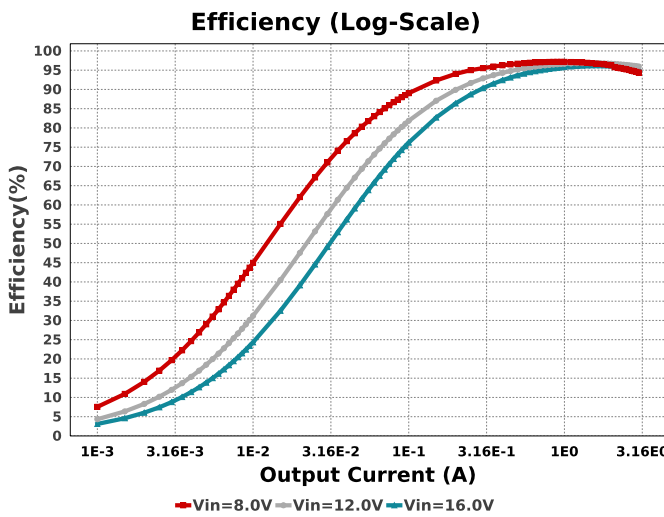
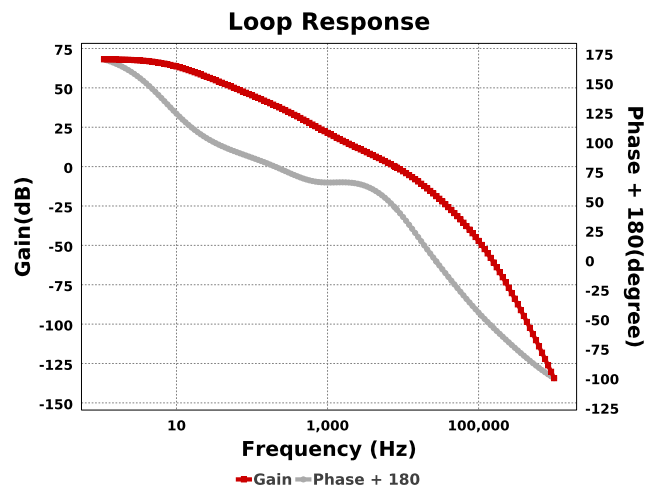
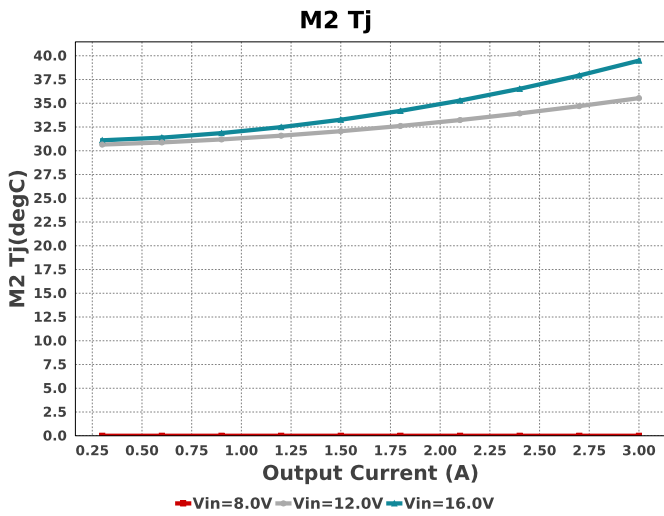
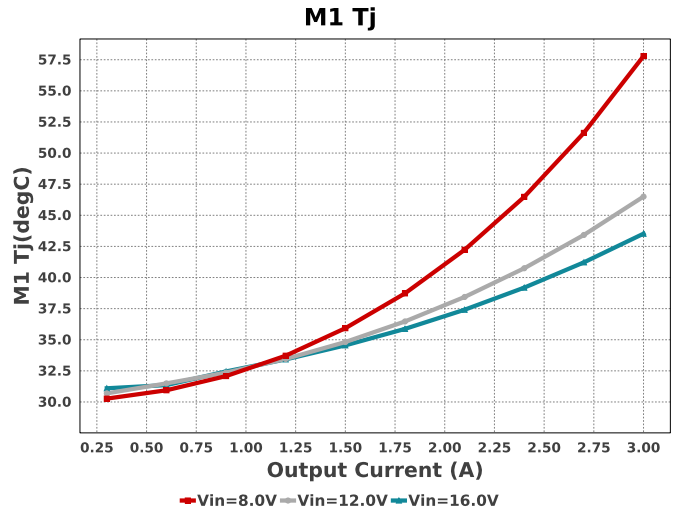
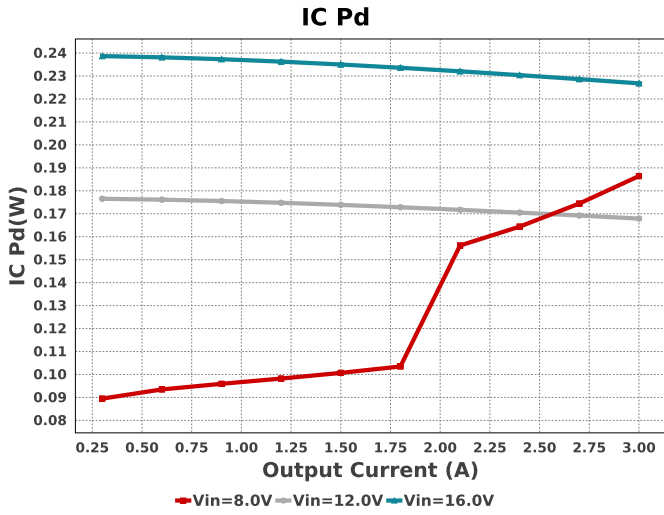

Operating Values

#	Name	Value	Category	Description
1.	Cin IRMS	130.436 mA	Capacitor	Input capacitor RMS ripple current
2.	Cin Pd	510.41 μW	Capacitor	Input capacitor power dissipation
3.	Cout IRMS	674.943 mA	Capacitor	Output capacitor RMS ripple current
4.	Cout Pd	12.3 mW	Capacitor	Output capacitor power dissipation
5.	Coutx IRMS	628.899 mA	Capacitor	Output capacitor_x RMS ripple current
6.	Coutx Pd	395.51 μW	Capacitor	Output capacitor_x power loss
7.	IC Ipk	3.901 A	IC	Peak switch current in IC
8.	IC Pd	186.42 mW	IC	IC power dissipation
9.	IC Tj	37.084 degC	IC	IC junction temperature
10.	IC Tolerance	12.0 mV	IC	IC Feedback Tolerance
11.	ICThetaJA Effective	38.0 degC/W	IC	Effective IC Junction-to-Ambient Thermal Resistance

#	Name	Value	Category	Description
12.	Iin Avg	3.576 A	IC	Average input current
13.	L Ipp	716.64 mA	Inductor	Peak-to-peak inductor ripple current
14.	L Pd	862.12 mW	Inductor	Inductor power dissipation
15.	M1 Pd	427.57 mW	Mosfet	M1 MOSFET total power dissipation
16.	M1 Tj	57.792 degC	Mosfet	M1 MOSFET junction temperature
17.	M2 Pd	0.0 W	Mosfet	M2 MOSFET total power dissipation
18.	M2 Tj	0.0 degC	Mosfet	M2 MOSFET junction temperature
19.	Cin Pd	510.41 μW	Power	Input capacitor power dissipation
20.	Cout Pd	12.3 mW	Power	Output capacitor power dissipation
21.	Coutx Pd	395.51 μW	Power	Output capacitor_x power loss
22.	IC Pd	186.42 mW	Power	IC power dissipation
23.	L Pd	862.12 mW	Power	Inductor power dissipation
24.	M1 Pd	427.57 mW	Power	M1 MOSFET total power dissipation
25.	M2 Pd	0.0 W	Power	M2 MOSFET total power dissipation
26.	Total Pd	1.607 W	Power	Total Power Dissipation
27.	BOM Count	25	System	Total Design BOM count
28.	Cross Freq	7.923 kHz	System Information	Bode plot crossover frequency
29.	Duty Cycle	15.603 %	System Information	Duty cycle
30.	Efficiency	94.383 %	System Information	Steady state efficiency
31.	FootPrint	324.0 mm ²	System Information	Total Foot Print Area of BOM components
32.	Frequency	198.807 kHz	System Information	Switching frequency
33.	Gain Marg	-14.355 dB	System Information	Bode Plot Gain Margin
34.	Iout	3.0 A	System Information	Iout operating point
35.	Low Freq Gain	61.07 dB	System Information	Gain at 1Hz
36.	Mode	CCM	System Information	Conduction Mode
37.	Phase Marg	57.384 deg	System Information	Bode Plot Phase Margin
38.	Pout	27.0 W	System Information	Total output power
39.	Total BOM	\$5.23	System Information	Total BOM Cost
40.	Vin	8.0 V	System Information	Vin operating point
41.	Vout	9.0 V	System Information	Operational Output Voltage
42.	Vout Actual	2.254 V	System Information	Vout Actual calculated based on selected voltage divider resistors
43.	Vout Tolerance	6.098 %	System Information	Vout Tolerance based on IC Tolerance (no load) and voltage divider resistors if applicable
44.	Vout p-p	6.956 mV	System Information	Peak-to-peak output ripple voltage
45.	Vref	19a	System Information	Register VREF

Design Inputs

Name	Value	Description
Iout	3.0	Maximum Output Current
VinMax	16.0	Maximum input voltage
VinMin	8.0	Minimum input voltage
Vout	9.0	Output Voltage
base_pn	TPS55288	Base Product Number
source	DC	Input Source Type
Ta	30.0	Ambient temperature

WEBENCH® Assembly

Component Testing

Some published data on components in datasheets such as Capacitor ESR and Inductor DC resistance is based on conservative values that will guarantee that the components always exceed the specification. For design purposes it is usually better to work with typical values. Since this data is not always available it is a good practice to measure the Capacitance and ESR values of C_{in} and C_{out} , and the inductance and DC resistance of L1 before assembly of the board. Any large discrepancies in values should be electrically simulated in WEBENCH to check for instabilities and thermally simulated in WebTHERM to make sure critical temperatures are not exceeded.

Soldering Component to Board

If board assembly is done in house it is best to tack down one terminal of a component on the board then solder the other terminal. For surface mount parts with large tabs, such as the DPAK, the tab on the back of the package should be pre-tinned with solder, then tacked into place by one of the pins. To solder the tab down to the board place the iron down on the board while resting against the tab, heating both surfaces simultaneously. Apply light pressure to the top of the plastic case until the solder flows around the part and the part is flush with the PCB. If the solder is not flowing around the board you may need a higher wattage iron (generally 25W to 30W is enough).

Initial Startup of Circuit

It is best to initially power up the board by setting the input supply voltage to the lowest operating input voltage 8.0V and set the input supply's current limit to zero. With the input supply off connect up the input supply to V_{in} and GND. Connect a digital volt meter and a load if needed to set the minimum load of the design from V_{out} and GND. Turn on the input supply and slowly turn up the current limit on the input supply. If the voltage starts to rise on the input supply continue increasing the input supply current limit while watching the output voltage. If the current increases on the input supply, but the voltage remains near zero, then there may be a short or a component misplaced on the board. Power down the board and visually inspect for solder bridges and recheck the diode and capacitor polarities. Once the power supply circuit is operational then more extensive testing may include full load testing, transient load and line tests to compare with simulation results.

Load Testing

The setup is the same as the initial startup, except that an additional digital voltmeter is connected between V_{in} and GND, a load is connected between V_{out} and GND and a current meter is connected in series between V_{out} and the load. The load must be able to handle at least rated output power + 50% (7.5 watts for this design). Ideally the load is supplied in the form of a variable load test unit. It can also be done in the form of suitably large power resistors. When using an oscilloscope to measure waveforms on the prototype board, the ground leads of the oscilloscope probes should be as short as possible and the area of the loop formed by the ground lead should be kept to a minimum. This will help reduce ground lead inductance and eliminate EMI noise that is not actually present in the circuit.

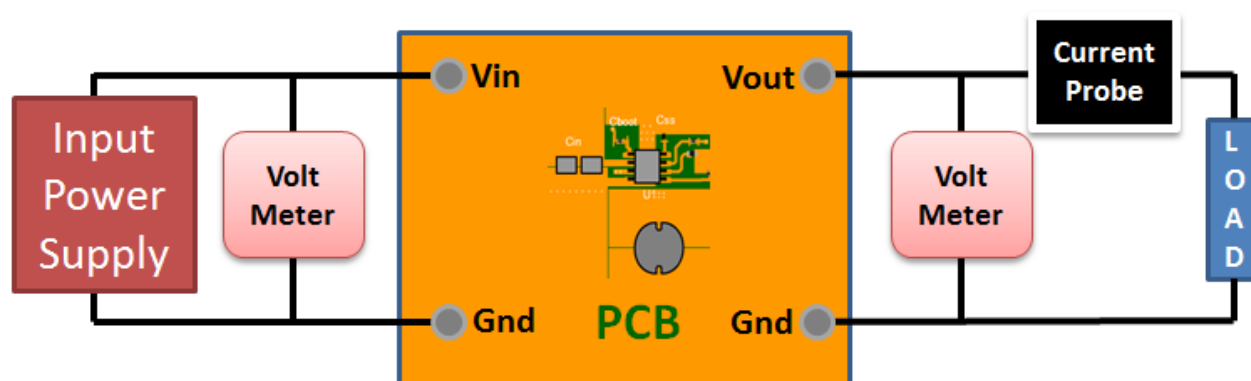

WEBENCH® Electrical Simulation Report

Design Id = 13

sim_id = 2

Simulation Type = Input Transient

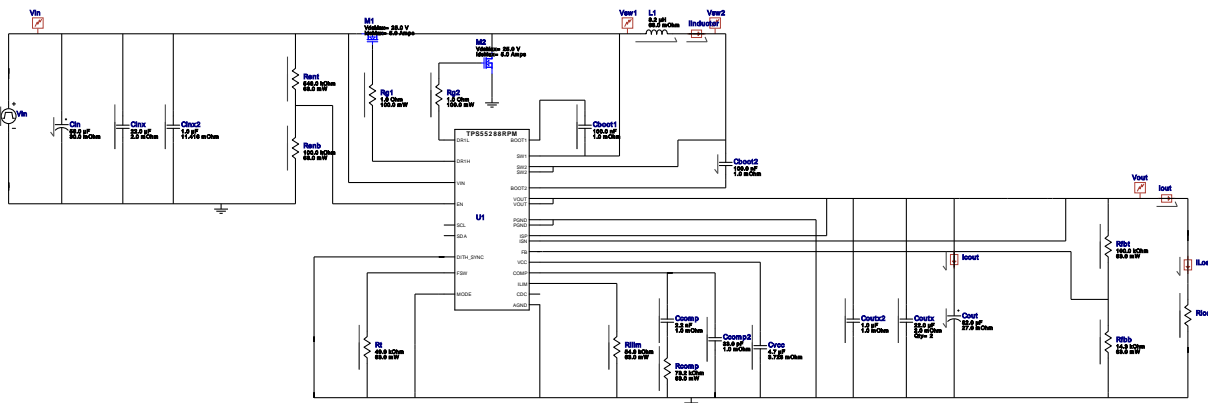

Simulation Parameters

#	Name	Parameter Name	Description	Values
1.	Rload	R	Load Resistance	3.0 Ohm

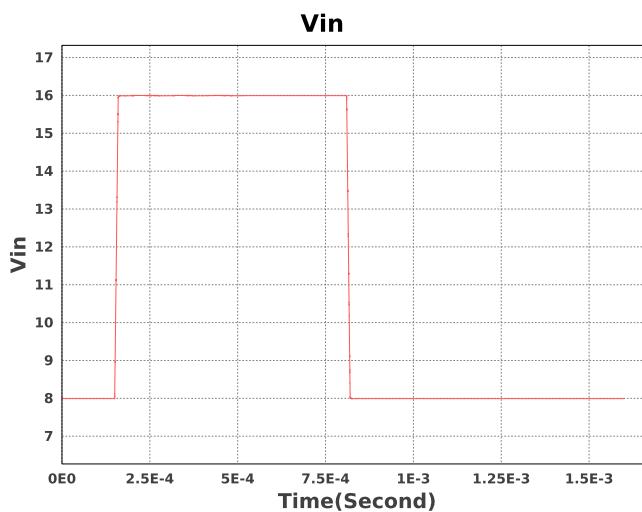
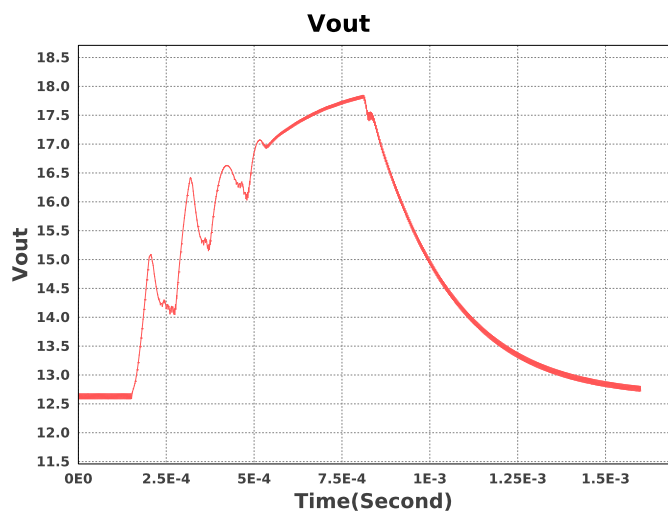

Design Assistance

1. Master key : FBC1FEC70EBBA06B6D3E4F0EB381A3E[v1]

2. **TPS55288** Product Folder : <http://www.ti.com/product/TPS55288> : contains the data sheet and other resources.

Important Notice and Disclaimer

TI provides technical and reliability data (including datasheets), design resources (including reference designs), application or other design advice, web tools, safety information, and other resources AS IS and with all faults, and disclaims all warranties. These resources are intended for skilled developers designing with TI products. You are solely responsible for (1) selecting the appropriate TI products for your application, (2) designing, validating and testing your application, and (3) ensuring your application meets applicable standards, and any other safety, security, or other requirements.

These resources are subject to change without notice. TI grants you permission to use these resources only for development of an application that uses the TI products described in the resource. Other reproduction and display of these resources is prohibited. No license is granted to any other TI intellectual property right or to any third party intellectual property right. TI disclaims responsibility for, and you will fully indemnify TI and its representatives against, any claims, damages, costs, losses, and liabilities arising out of your use of these resources.

Providing these resources does not expand or otherwise alter TI's applicable Terms of Sale or other applicable terms available either on ti.com or provided in conjunction with TI products.