

WEBENCH® Design Report

Design : 25 TPS61088RHLL
 TPS61088RHLL 5.0V-5.5V to 12.00V @ 4.0A

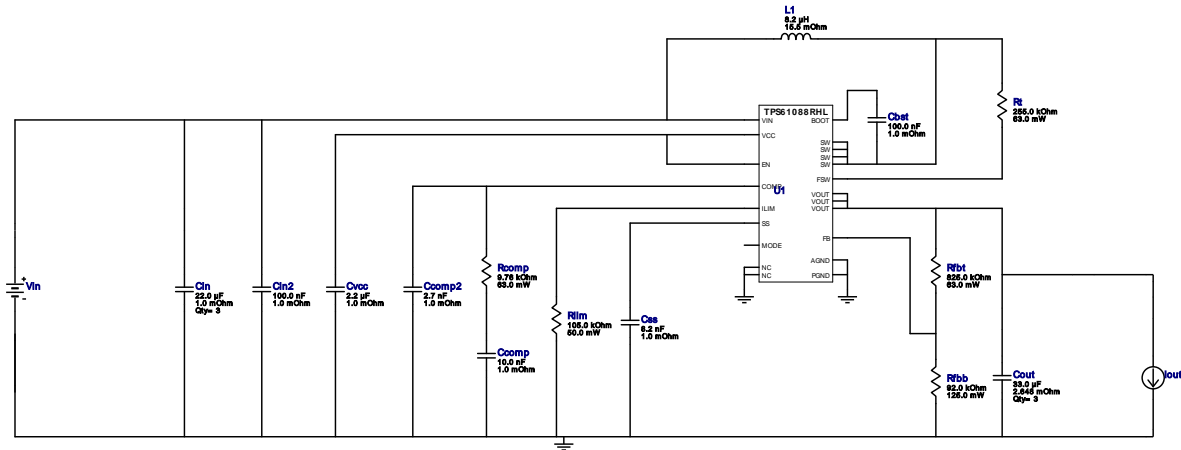

Electrical BOM

| Name | Manufacturer | Part Number | Properties | Qty | Price | Footprint |
|--------|--------------|------------------------------------|--|-----|--------|-----------------------------|
| Cbst | MuRata | GRM155R61C104KA88D Series= X5R | Cap= 100.0 nF ESR= 1.0 mOhm VDC= 16.0 V IRMS= 0.0 A | 1 | \$0.01 | 0402 3 mm ² |
| Ccomp | MuRata | GRM155R61C103KA01D Series= X5R | Cap= 10.0 nF ESR= 1.0 mOhm VDC= 16.0 V IRMS= 0.0 A | 1 | \$0.01 | 0402 3 mm ² |
| Ccomp2 | MuRata | GRM033R71C272KA88D Series= X7R | Cap= 2.7 nF ESR= 1.0 mOhm VDC= 16.0 V IRMS= 0.0 A | 1 | \$0.01 | 0201 2 mm ² |
| Cin | TDK | C2012X7S1A226M125AC Series= X7S | Cap= 22.0 uF ESR= 1.0 mOhm VDC= 10.0 V IRMS= 0.0 A | 3 | \$0.33 | 0805 7 mm ² |
| Cin2 | MuRata | GRM155R71A104KA01D Series= X7R | Cap= 100.0 nF ESR= 1.0 mOhm VDC= 10.0 V IRMS= 0.0 A | 1 | \$0.01 | 0402 3 mm ² |
| Cout | TDK | C3216X5R1E336M160AC Series= X5R | Cap= 33.0 uF ESR= 2.648 mOhm VDC= 25.0 V IRMS= 4.4586 A | 3 | \$0.44 | 1206_180 11 mm ² |
| Css | MuRata | GRM155R71E822KA01D Series= X7R | Cap= 8.2 nF ESR= 1.0 mOhm VDC= 25.0 V IRMS= 0.0 A | 1 | \$0.01 | 0402 3 mm ² |
| Cvcc | Taiyo Yuden | EMK212BJ225KG-T Series= X5R | Cap= 2.2 uF ESR= 1.0 mOhm VDC= 16.0 V IRMS= 0.0 A | 1 | \$0.03 | 0805 7 mm ² |

| Name | Manufacturer | Part Number | Properties | Qty | Price | Footprint |
|-------|-------------------|--------------------------------------|--|-----|--------|--|
| L1 | Bourns | SRP1270-8R2M | L= 8.2 µH DCR= 15.5 mOhm | 1 | \$0.68 |  SRP1270 246 mm² |
| Rcomp | Vishay-Dale | CRCW04029K76FKED Series= CRCW..e3 | Res= 9.76 kOhm Power= 63.0 mW Tolerance= 1.0% | 1 | \$0.01 |  0402 3 mm² |
| Rfbb | Yageo | RT0805BRD0792KL Series= RT0805 | Res= 92.0 kOhm Power= 125.0 mW Tolerance= 0.1% | 1 | \$0.05 |  0805 7 mm² |
| Rfbt | Vishay-Dale | CRCW0402825KFKED Series= CRCW..e3 | Res= 825.0 kOhm Power= 63.0 mW Tolerance= 1.0% | 1 | \$0.01 |  0402 3 mm² |
| Rlim | Yageo | RC0201FR-07105KL Series= ? | Res= 105.0 kOhm Power= 50.0 mW Tolerance= 1.0% | 1 | \$0.01 |  0201 2 mm² |
| Rt | Vishay-Dale | CRCW0402255KFKED Series= CRCW..e3 | Res= 255.0 kOhm Power= 63.0 mW Tolerance= 1.0% | 1 | \$0.01 |  0402 3 mm² |
| U1 | Texas Instruments | TPS61088RHLR | Switcher | 1 | \$1.60 |  RHL0020A 25 mm² |

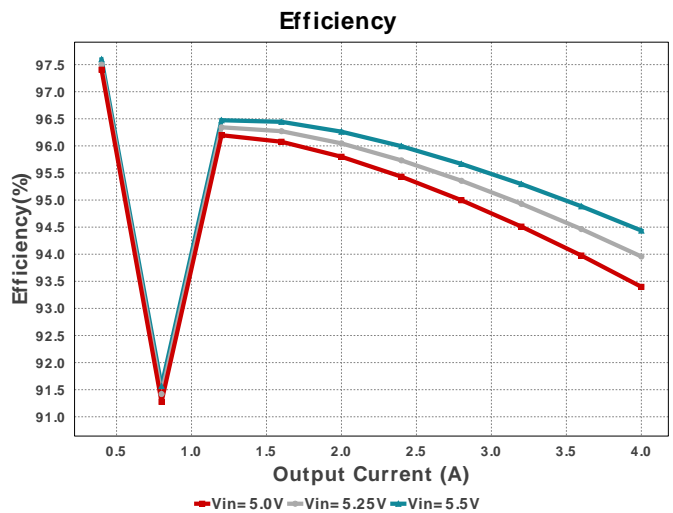
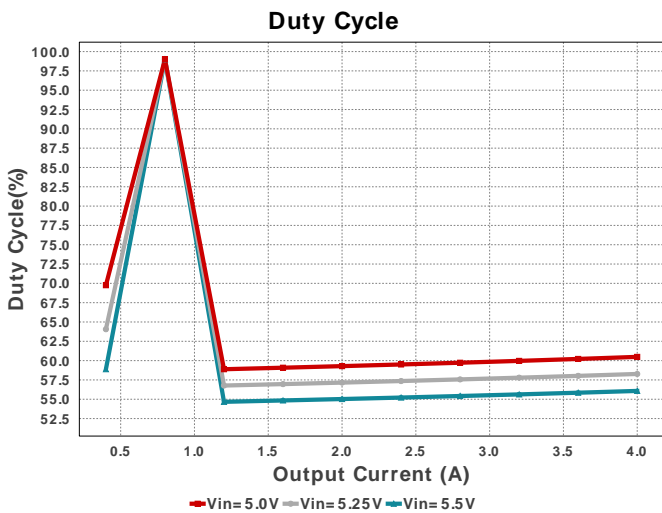
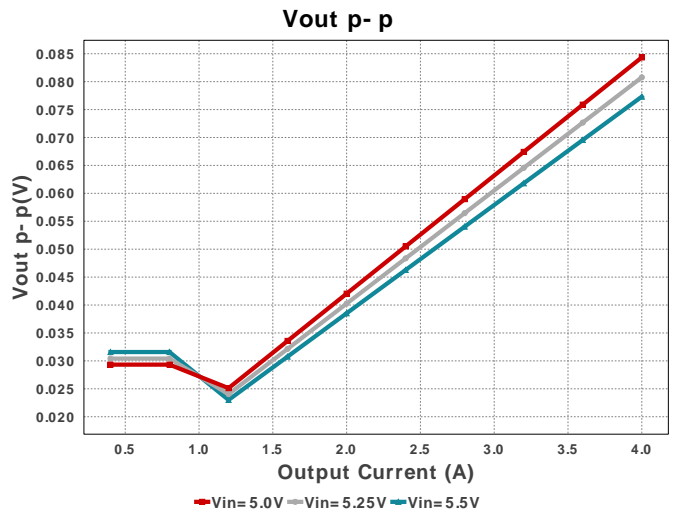
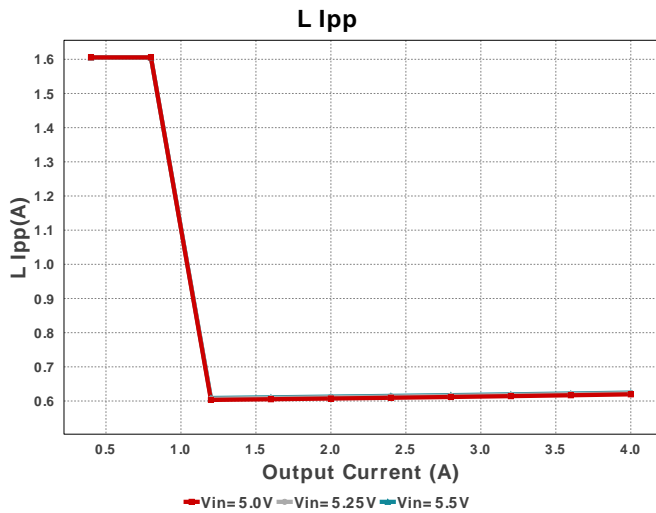

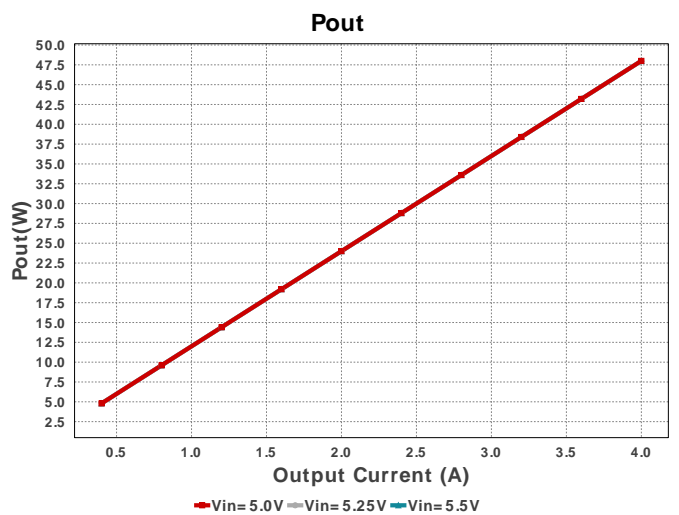
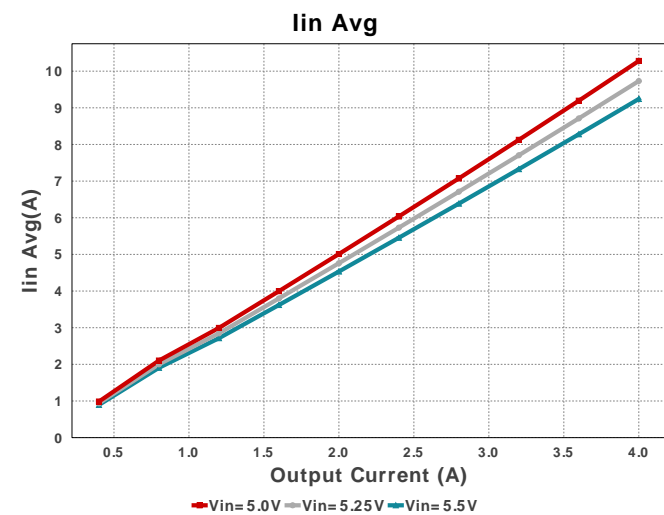
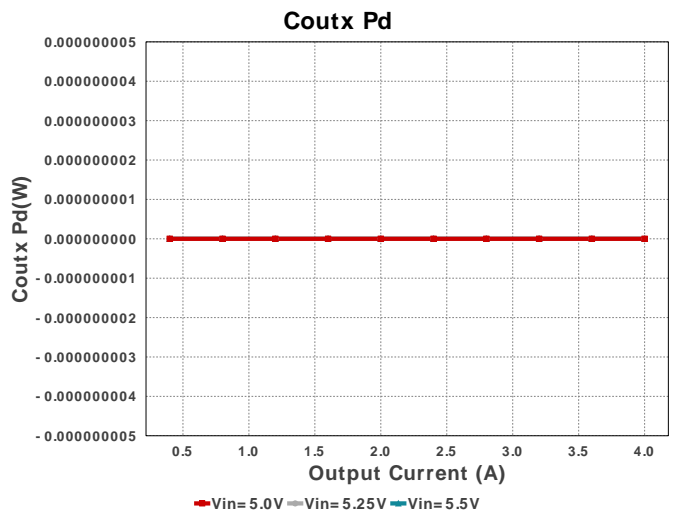
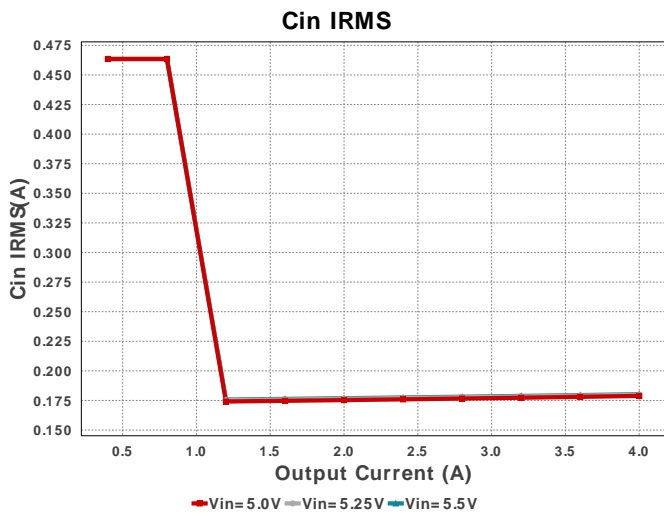
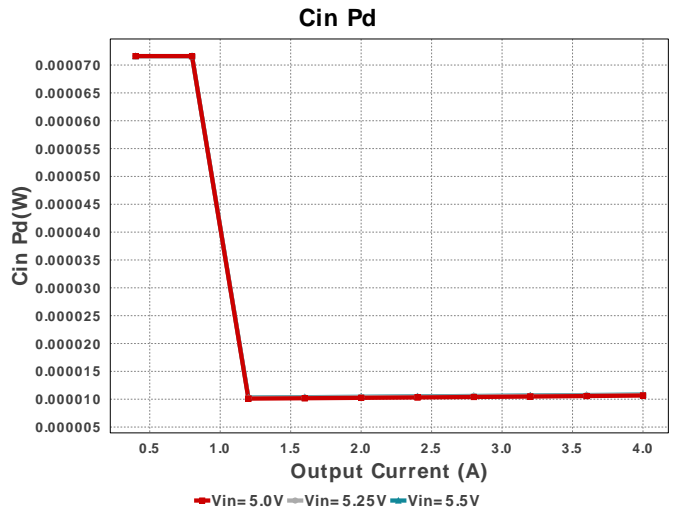
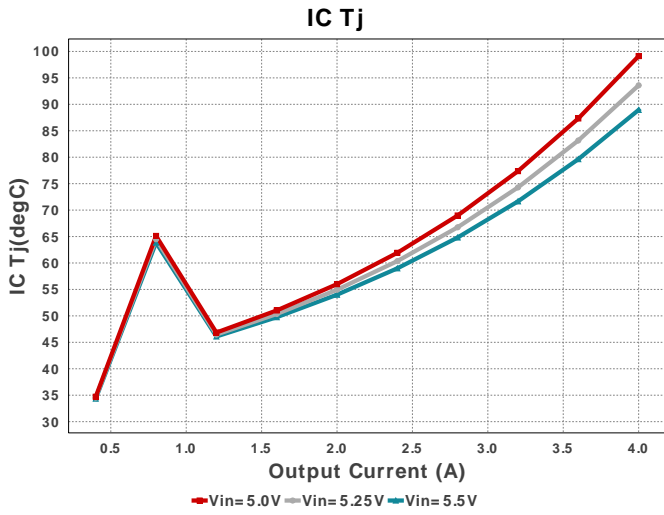

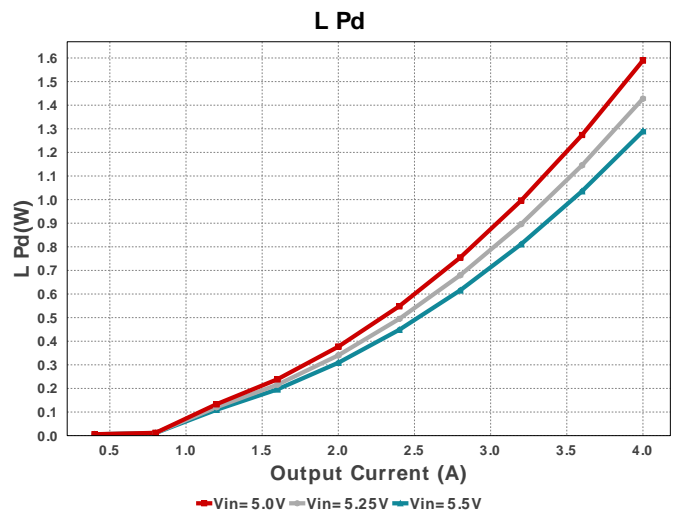
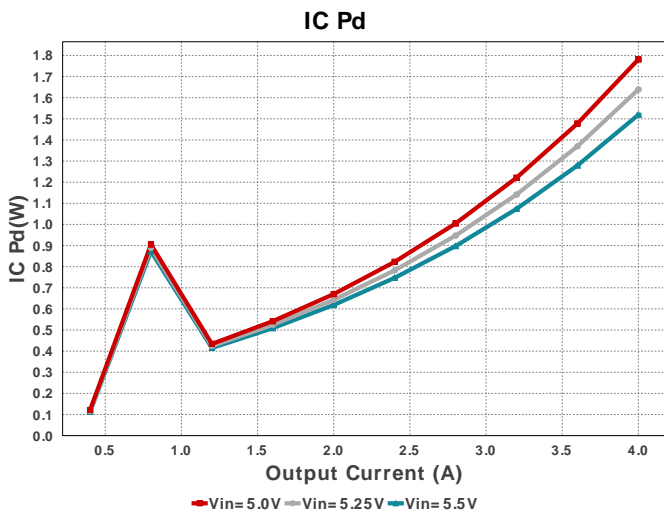
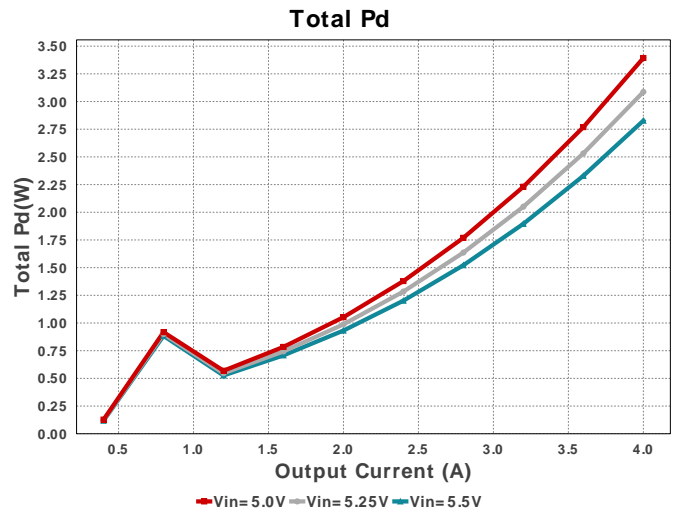
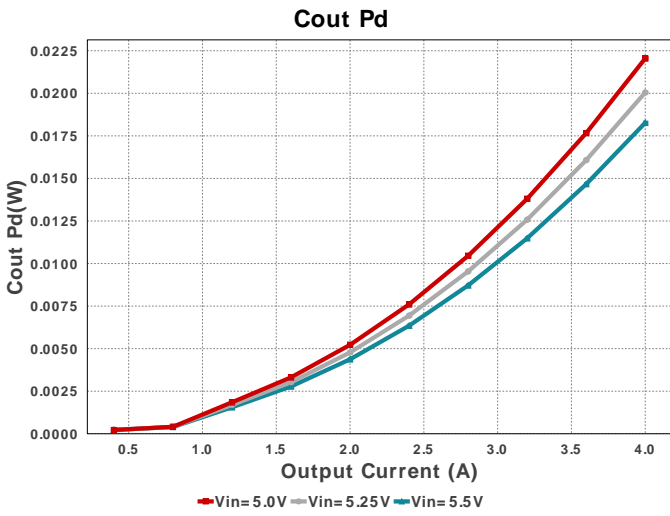
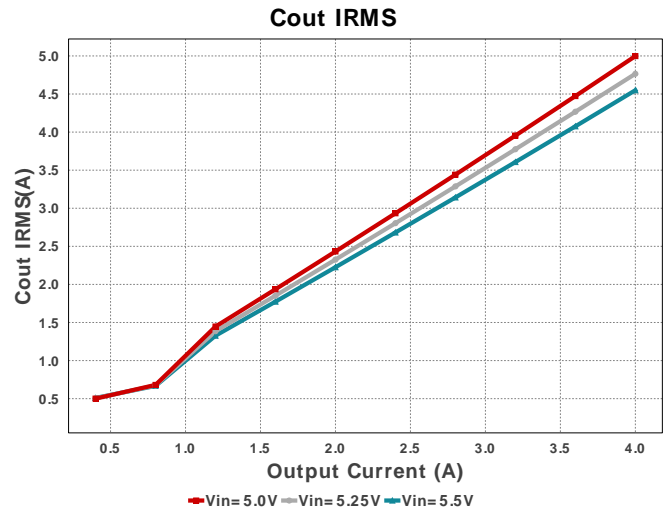
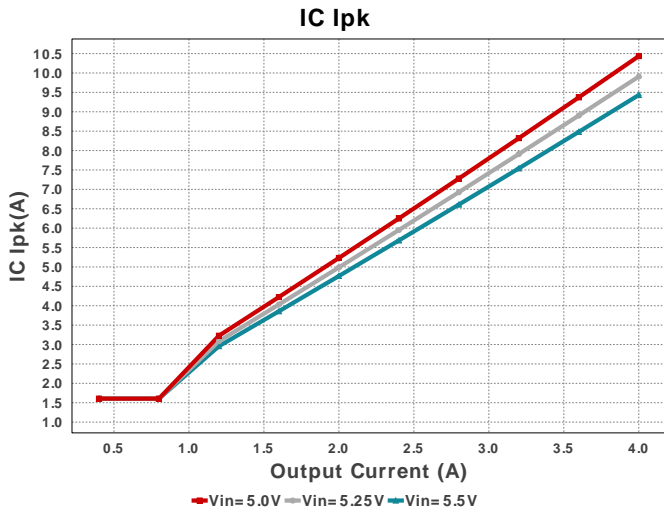

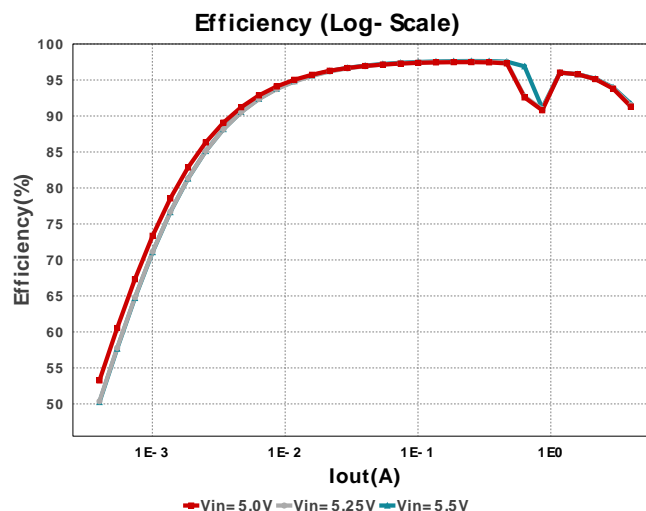
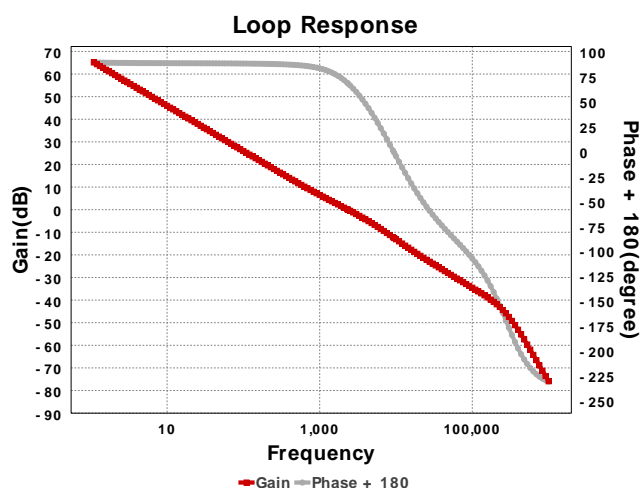

Operating Values

| # | Name | Value | Category | Description |
|-----|----------------|-----------------------|-----------|--|
| 1. | Cin IRMS | 178.845 mA | Capacitor | Input capacitor RMS ripple current |
| 2. | Cin Pd | 10.662 μ W | Capacitor | Input capacitor power dissipation |
| 3. | Cout IRMS | 4.998 A | Capacitor | Output capacitor RMS ripple current |
| 4. | Cout Pd | 22.048 mW | Capacitor | Output capacitor power dissipation |
| 5. | Coutx Pd | 0.0 W | Capacitor | Output capacitor_x power loss |
| 6. | IC Ipk | 10.435 A | IC | Peak switch current in IC |
| 7. | IC Pd | 1.781 W | IC | IC power dissipation |
| 8. | IC Tj | 99.118 degC | IC | IC junction temperature |
| 9. | ICThetaJA | 38.8 degC/W | IC | IC junction-to-ambient thermal resistance |
| 10. | Iin Avg | 10.279 A | IC | Average input current |
| 11. | L Ipp | 619.54 mA | Inductor | Peak-to-peak inductor ripple current |
| 12. | L Pd | 1.59 W | Inductor | Inductor power dissipation |
| 13. | Cin Pd | 10.662 μ W | Power | Input capacitor power dissipation |
| 14. | Cout Pd | 22.048 mW | Power | Output capacitor power dissipation |
| 15. | Coutx Pd | 0.0 W | Power | Output capacitor_x power loss |
| 16. | IC Pd | 1.781 W | Power | IC power dissipation |
| 17. | L Pd | 1.59 W | Power | Inductor power dissipation |
| 18. | Total Pd | 3.393 W | Power | Total Power Dissipation |
| 19. | BOM Count | 19 | System | Total Design BOM count |
| 20. | Cross Freq | 2.299 kHz | System | Bode plot crossover frequency |
| 21. | Duty Cycle | 60.484 % | System | Duty cycle |
| 22. | Efficiency | 93.398 % | System | Steady state efficiency |
| 23. | FootPrint | 363.0 mm ² | System | Total Foot Print Area of BOM components |
| 24. | Frequency | 595.291 kHz | System | Switching frequency |
| 25. | Gain Marg | -12.563 dB | System | Bode Plot Gain Margin |
| 26. | Iout | 4.0 A | System | Iout operating point |
| 27. | Low Freq Gain | 64.722 dB | System | Gain at 1Hz |
| 28. | Mode | BOOST CCM | System | PWM/PFM Mode |
| 29. | Phase Marg | 71.698 deg | System | Bode Plot Phase Margin |
| 30. | Pout | 48.0 W | System | Total output power |
| 31. | Total BOM | \$4.76 | System | Total BOM Cost |
| 32. | Vin | 5.0 V | System | Vin operating point |
| 33. | Vout Actual | 12.001 V | System | Vout Actual calculated based on selected voltage divider resistors |
| 34. | Vout Tolerance | 3.633 % | System | Vout Tolerance based on IC Tolerance (no load) and voltage divider resistors if applicable |
| 35. | Vout p-p | 84.339 mV | System | Peak-to-peak output ripple voltage |

Design Inputs

| Name | Value | Description |
|---------|----------|------------------------|
| Iout | 4.0 | Maximum Output Current |
| VinMax | 5.5 | Maximum input voltage |
| VinMin | 5.0 | Minimum input voltage |
| Vout | 12.0 | Output Voltage |
| base_pn | TPS61088 | Base Product Number |
| source | DC | Input Source Type |
| Ta | 30.0 | Ambient temperature |

WEBENCH® Assembly

Component Testing

Some published data on components in datasheets such as Capacitor ESR and Inductor DC resistance is based on conservative values that will guarantee that the components always exceed the specification. For design purposes it is usually better to work with typical values. Since this data is not always available it is a good practice to measure the Capacitance and ESR values of C_{in} and C_{out} , and the inductance and DC resistance of L1 before assembly of the board. Any large discrepancies in values should be electrically simulated in WEBENCH to check for instabilities and thermally simulated in WebTHERM to make sure critical temperatures are not exceeded.

Soldering Component to Board

If board assembly is done in house it is best to tack down one terminal of a component on the board then solder the other terminal. For surface mount parts with large tabs, such as the DPAK, the tab on the back of the package should be pre-tinned with solder, then tacked into place by one of the pins. To solder the tab down to the board place the iron down on the board while resting against the tab, heating both surfaces simultaneously. Apply light pressure to the top of the plastic case until the solder flows around the part and the part is flush with the PCB. If the solder is not flowing around the board you may need a higher wattage iron (generally 25W to 30W is enough).

Initial Startup of Circuit

It is best to initially power up the board by setting the input supply voltage to the lowest operating input voltage 5.0V and set the input supply's current limit to zero. With the input supply off connect up the input supply to V_{in} and GND. Connect a digital volt meter and a load if needed to set the minimum load of the design from V_{out} and GND. Turn on the input supply and slowly turn up the current limit on the input supply. If the voltage starts to rise on the input supply continue increasing the input supply current limit while watching the output voltage. If the current increases on the input supply, but the voltage remains near zero, then there may be a short or a component misplaced on the board. Power down the board and visually inspect for solder bridges and recheck the diode and capacitor polarities. Once the power supply circuit is operational then more extensive testing may include full load testing, transient load and line tests to compare with simulation results.

Load Testing

The setup is the same as the initial startup, except that an additional digital voltmeter is connected between V_{in} and GND, a load is connected between V_{out} and GND and a current meter is connected in series between V_{out} and the load. The load must be able to handle at least rated output power + 50% (7.5 watts for this design). Ideally the load is supplied in the form of a variable load test unit. It can also be done in the form of suitably large power resistors. When using an oscilloscope to measure waveforms on the prototype board, the ground leads of the oscilloscope probes should be as short as possible and the area of the loop formed by the ground lead should be kept to a minimum. This will help reduce ground lead inductance and eliminate EMI noise that is not actually present in the circuit.



WEBENCH® Electrical Simulation Report

Design Id = 25

sim_id = 1

Simulation Type = Startup

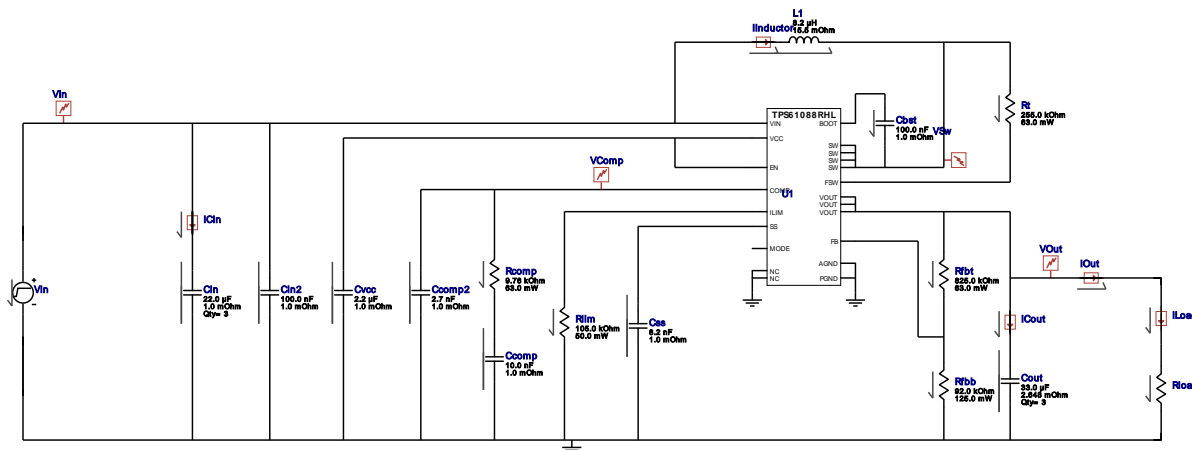

Simulation Parameters

| # | Name | Parameter Name | Description | Values |
|----|-------|----------------|-------------------|---------|
| 1. | L1 | IC | Initial Condition | 0 A |
| 2. | Rload | R | Load Resistance | 3.0 Ohm |

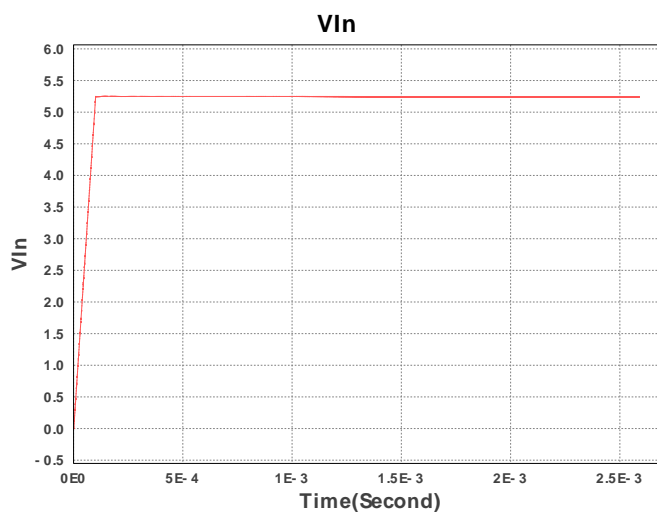
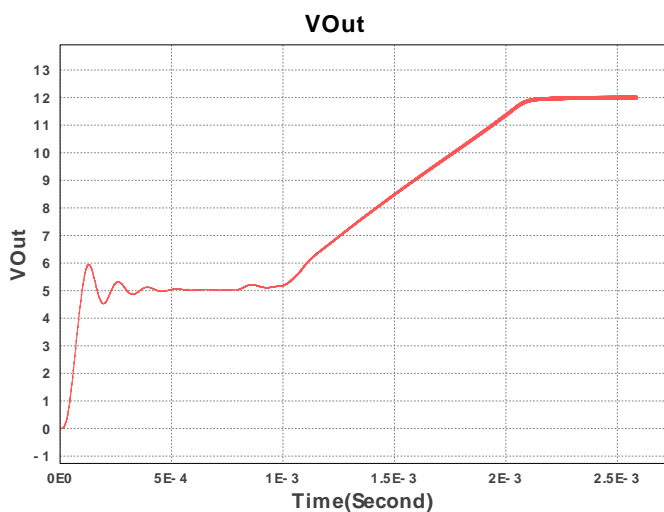

Design Assistance

1. Master key : 290B1A9D9DBBAB02[v1]
2. **TPS61088** Product Folder : <http://www.ti.com/product/TPS61088> : contains the data sheet and other resources.

Important Notice and Disclaimer

TI provides technical and reliability data (including datasheets), design resources (including reference designs), application or other design advice, web tools, safety information, and other resources AS IS and with all faults, and disclaims all warranties. These resources are intended for skilled developers designing with TI products. You are solely responsible for (1) selecting the appropriate TI products for your application, (2) designing, validating and testing your application, and (3) ensuring your application meets applicable standards, and any other safety, security, or other requirements.

These resources are subject to change without notice. TI grants you permission to use these resources only for development of an application that uses the TI products described in the resource. Other reproduction and display of these resources is prohibited. No license is granted to any other TI intellectual property right or to any third party intellectual property right. TI disclaims responsibility for, and you will fully indemnify TI and its representatives against, any claims, damages, costs, losses, and liabilities arising out of your use of these resources.

Providing these resources does not expand or otherwise alter TI's applicable Terms of Sale or other applicable terms available either on ti.com or provided in conjunction with TI products.