

WEBENCH® Design Report

Design : 341 TPS54335ADDAR
 TPS54335ADDAR 8V-28V to 5.00V @ 3A

Vout = 5.0V
 Iout = 3.0A

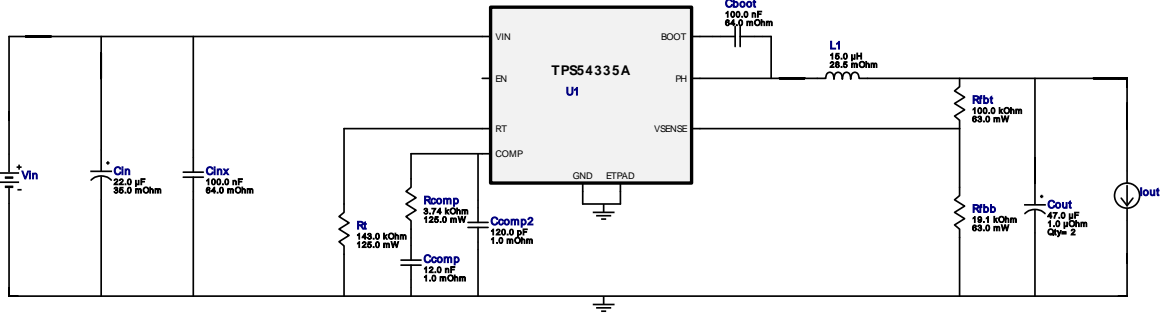

Design Alerts

Phase margin is too low
Phase margin: 34.44deg < Specification 35.0deg

This may lead to unstable design. Please click 'APPLY' to auto-recompensate or change your design.

Electrical BOM

Name	Manufacturer	Part Number	Properties	Qty	Price	Footprint
Cboot	Kemet	C0805C104M5RACTU Series= X7R	Cap= 100.0 nF ESR= 64.0 mOhm VDC= 50.0 V IRMS= 1.64 A	1	\$0.01	0805 7 mm ²
Ccomp	MuRata	GRM188R71H123KA01D Series= X7R	Cap= 12.0 nF ESR= 1.0 mOhm VDC= 50.0 V IRMS= 0.0 A	1	\$0.01	0603 5 mm ²
Ccomp2	MuRata	GRM033R71E121KA01D Series= X7R	Cap= 120.0 pF ESR= 1.0 mOhm VDC= 25.0 V IRMS= 0.0 A	1	\$0.01	0201 2 mm ²
Cin	Panasonic	35SVPF22M Series= SVPF	Cap= 22.0 uF ESR= 35.0 mOhm VDC= 35.0 V IRMS= 2.6 A	1	\$0.44	CAPSMT_62_F61 74 mm ²
Cinx	Kemet	C0805C104M5RACTU Series= X7R	Cap= 100.0 nF ESR= 64.0 mOhm VDC= 50.0 V IRMS= 1.64 A	1	\$0.01	0805 7 mm ²
Cout	CUSTOM	CUSTOM Series= SVPG	Cap= 47.0 uF ESR= 1.0 uOhm VDC= 16.0 V IRMS= 5.8 A	2	NA	CAPSMT_62_C10 0 mm ²
L1	Bourns	SRR1280-150M	L= 15.0 uH 28.5 mOhm	1	\$0.50	SRR1280 210 mm ²
Rcomp	CUSTOM	CUSTOM Series= ERJ-6E	Res= 3.74 kOhm Power= 125.0 mW Tolerance= 1.0%	1	NA	0805 0 mm ²

Name	Manufacturer	Part Number	Properties	Qty	Price	Footprint
Rfbb	Vishay-Dale	CRCW040219K1FKED Series= CRCW..e3	Res= 19.1 kOhm Power= 63.0 mW Tolerance= 1.0%	1	\$0.01	0402 3 mm ²
Rfbt	Vishay-Dale	CRCW0402100KFKED Series= CRCW..e3	Res= 100.0 kOhm Power= 63.0 mW Tolerance= 1.0%	1	\$0.01	0402 3 mm ²
Rt	Panasonic	ERJ-6ENF1433V Series= ERJ-6E	Res= 143.0 kOhm Power= 125.0 mW Tolerance= 1.0%	1	\$0.01	0805 7 mm ²
U1	Texas Instruments	TPS54335ADDAR	Switcher	1	\$0.85	R-PDSO-G8 55 mm ²

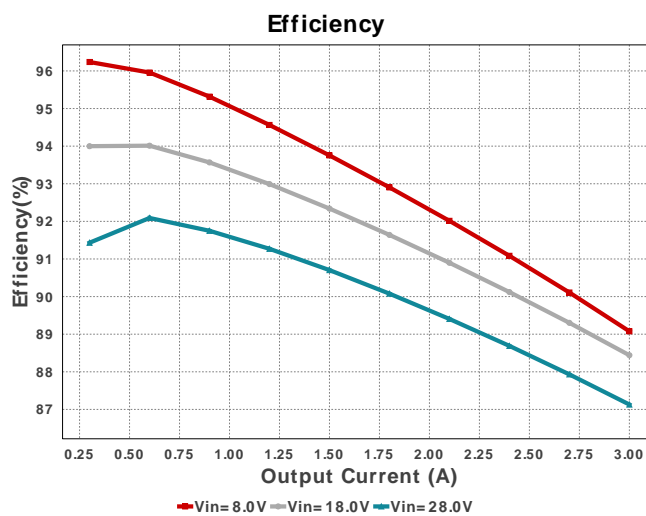
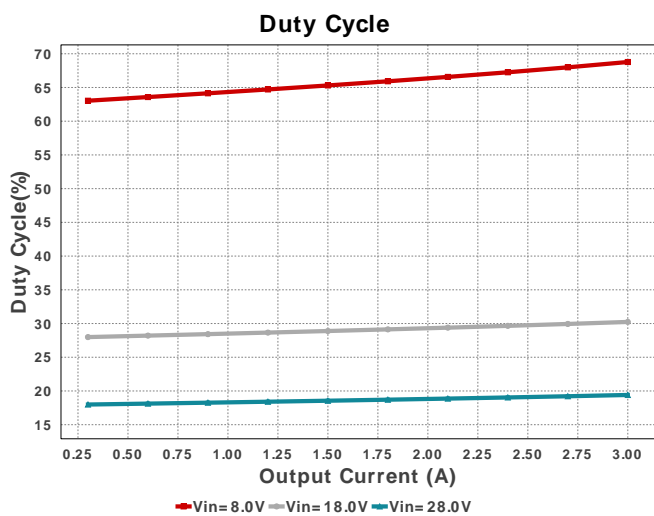
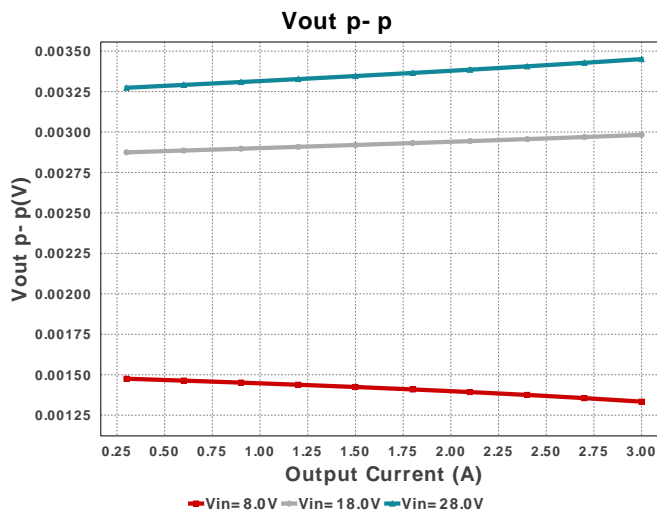
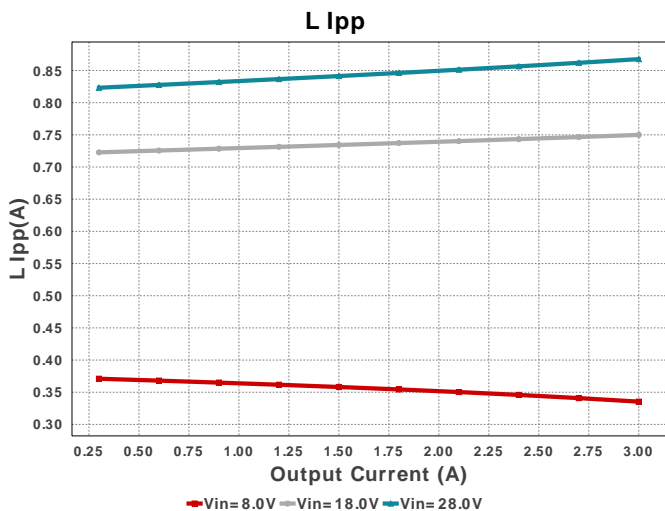

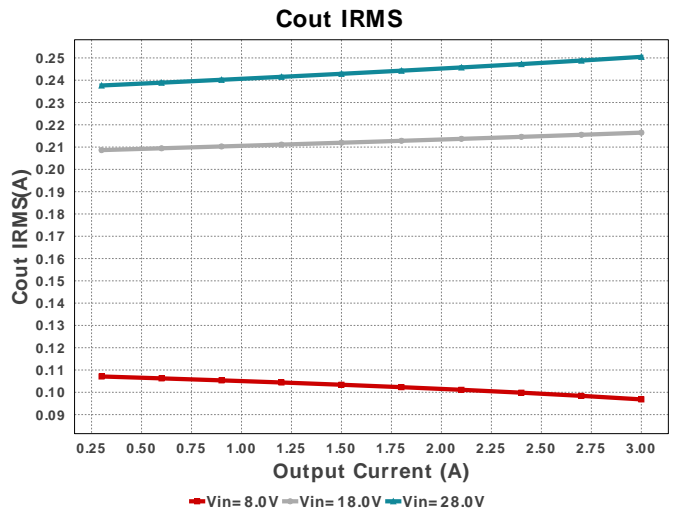
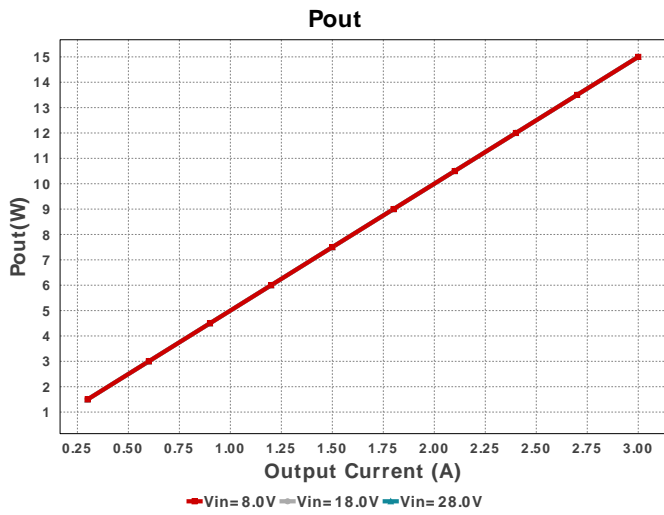
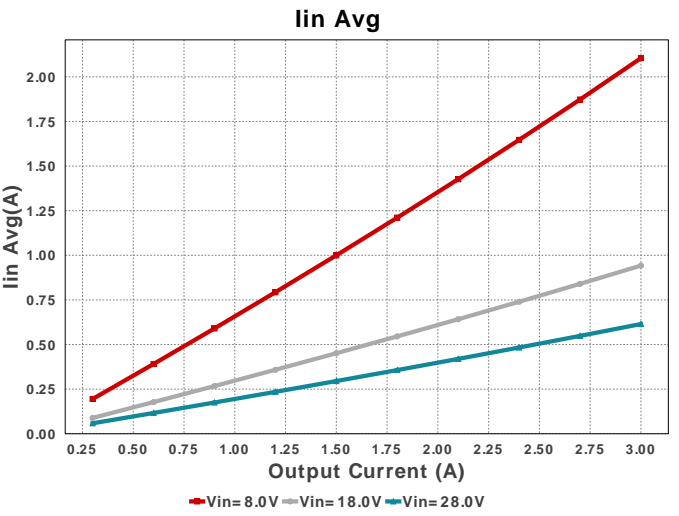
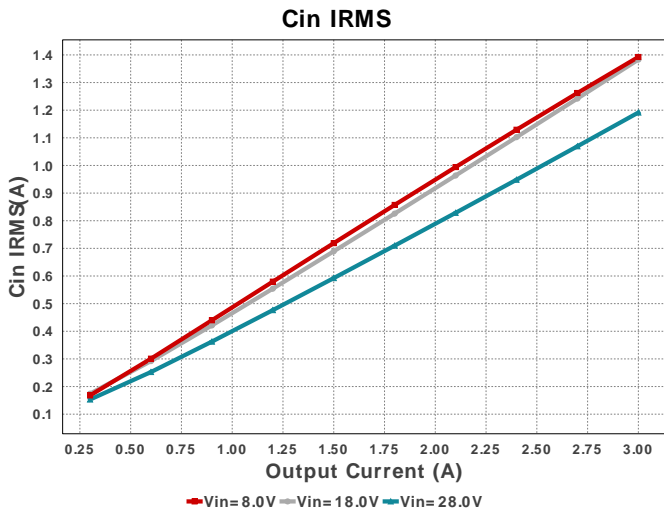
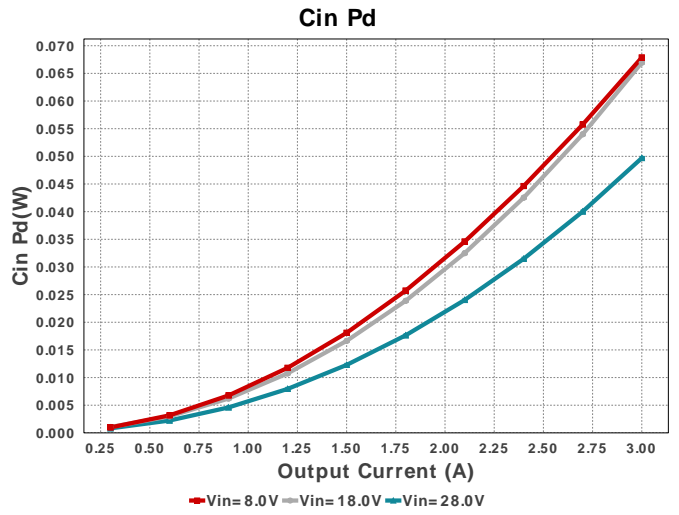
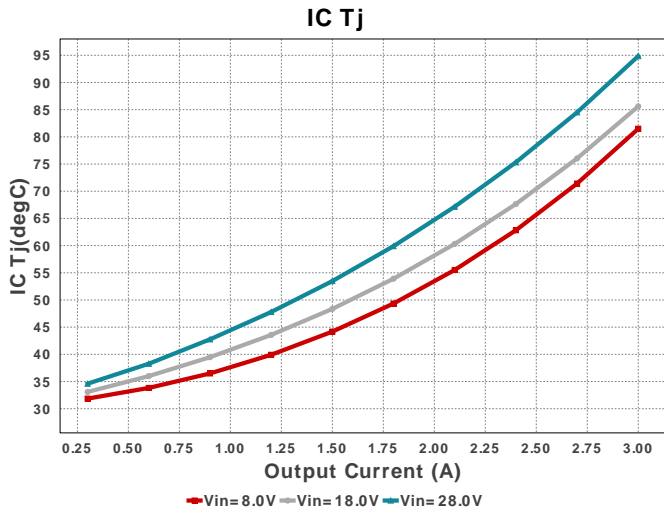

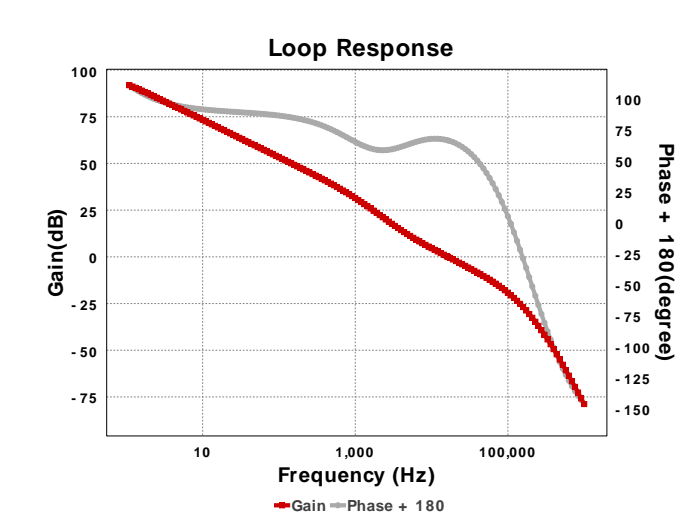
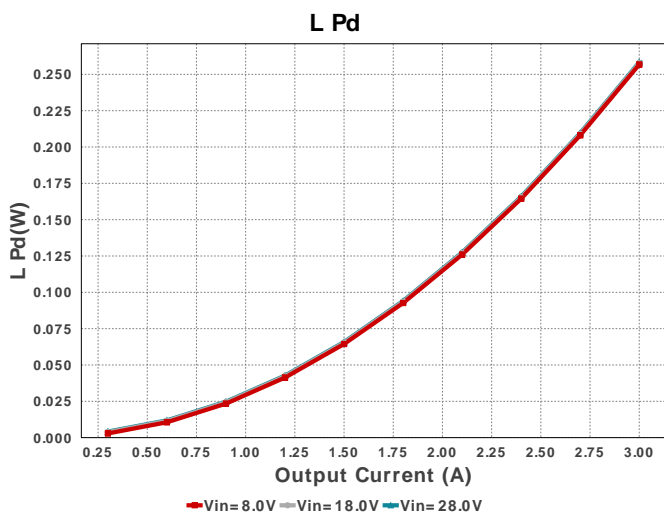
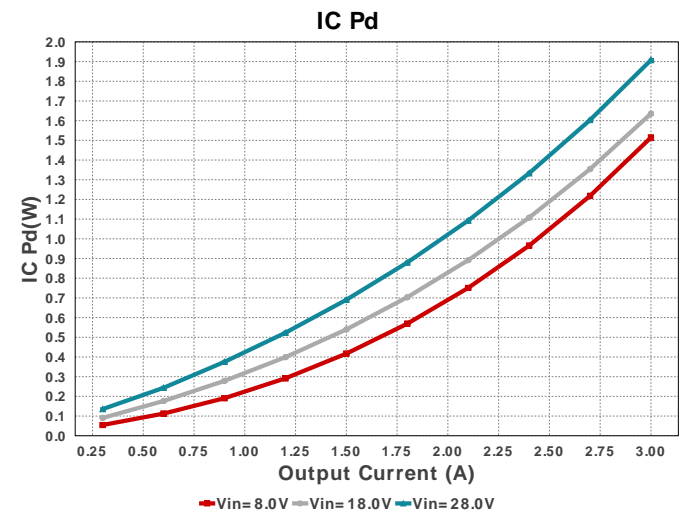
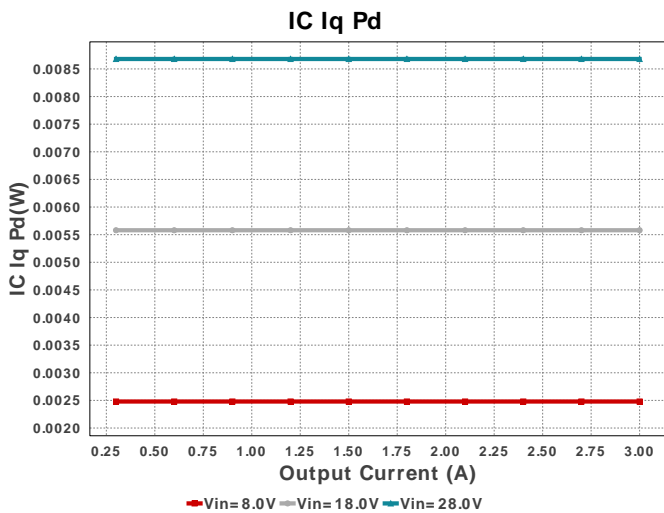
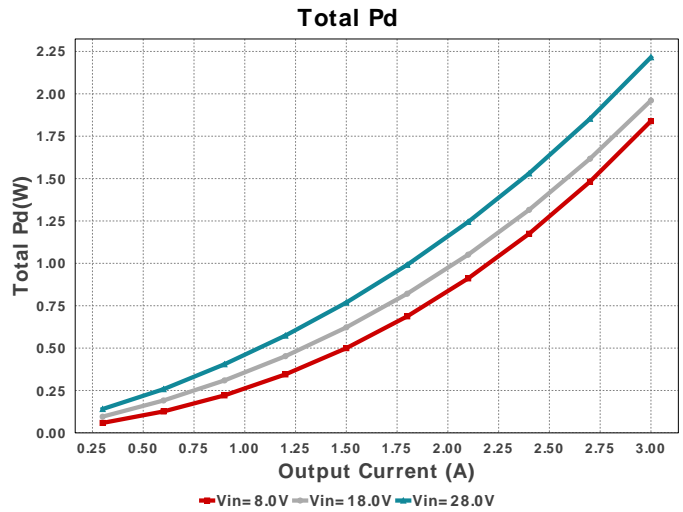
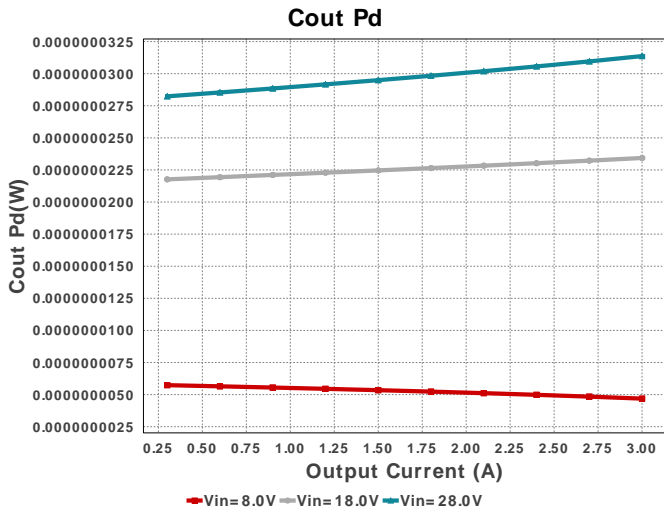

Operating Values

#	Name	Value	Category	Description
1.	BOM Count	13		Total Design BOM count
2.	Total BOM	NA		Total BOM Cost
3.	Cin IRMS	1.192 A	Capacitor	Input capacitor RMS ripple current
4.	Cin Pd	49.693 mW	Capacitor	Input capacitor power dissipation
5.	Cout IRMS	250.472 mA	Capacitor	Output capacitor RMS ripple current
6.	Cout Pd	31.368 nW	Capacitor	Output capacitor power dissipation
7.	IC Iq Pd	8.68 mW	IC	IC Iq Pd
8.	IC Pd	1.908 W	IC	IC power dissipation
9.	IC Tj	94.855 degC	IC	IC junction temperature
10.	IC Tolerance	12.0 mV	IC	IC Feedback Tolerance
11.	ICThetaJA Effective	34.0 degC/W	IC	Effective IC Junction-to-Ambient Thermal Resistance

#	Name	Value	Category	Description
12.	Iin Avg	614.85 mA	IC	Average input current
13.	L Ipp	867.661 mA	Inductor	Peak-to-peak inductor ripple current
14.	L Pd	258.29 mW	Inductor	Inductor power dissipation
15.	Cin Pd	49.693 mW	Power	Input capacitor power dissipation
16.	Cout Pd	31.368 nW	Power	Output capacitor power dissipation
17.	IC Pd	1.908 W	Power	IC power dissipation
18.	L Pd	258.29 mW	Power	Inductor power dissipation
19.	Total Pd	2.216 W	Power	Total Power Dissipation
20.	Cross Freq	16.37 kHz	System Information	Bode plot crossover frequency
21.	Duty Cycle	19.406 %	System Information	Duty cycle
22.	Efficiency	87.13 %	System Information	Steady state efficiency
23.	FootPrint	527.0 mm ²	System Information	Total Foot Print Area of BOM components
24.	Frequency	334.388 kHz	System Information	Switching frequency
25.	Gain Marg	-20.479 dB	System Information	Bode Plot Gain Margin
26.	Iout	3.0 A	System Information	Iout operating point
27.	Low Freq Gain	91.892 dB	System Information	Gain at 1Hz
28.	Mode	CCM	System Information	Conduction Mode
29.	Phase Marg	67.147 deg	System Information	Bode Plot Phase Margin
30.	Pout	15.0 W	System Information	Total output power
31.	Vin	28.0 V	System Information	Vin operating point
32.	Vout	5.0 V	System Information	Operational Output Voltage
33.	Vout Actual	4.988 V	System Information	Vout Actual calculated based on selected voltage divider resistors
34.	Vout Tolerance	3.222 %	System Information	Vout Tolerance based on IC Tolerance (no load) and voltage divider resistors if applicable
35.	Vout p-p	3.45 mV	System Information	Peak-to-peak output ripple voltage

Design Inputs

Name	Value	Description
Iout	3.0	Maximum Output Current
VinMax	28.0	Maximum input voltage
VinMin	8.0	Minimum input voltage
Vout	5.0	Output Voltage
base_pn	TPS54335A	Base Product Number
source	DC	Input Source Type
Ta	30.0	Ambient temperature

WEBENCH® Assembly

Component Testing

Some published data on components in datasheets such as Capacitor ESR and Inductor DC resistance is based on conservative values that will guarantee that the components always exceed the specification. For design purposes it is usually better to work with typical values. Since this data is not always available it is a good practice to measure the Capacitance and ESR values of C_{in} and C_{out} , and the inductance and DC resistance of L1 before assembly of the board. Any large discrepancies in values should be electrically simulated in WEBENCH to check for instabilities and thermally simulated in WebTHERM to make sure critical temperatures are not exceeded.

Soldering Component to Board

If board assembly is done in house it is best to tack down one terminal of a component on the board then solder the other terminal. For surface mount parts with large tabs, such as the DPAK, the tab on the back of the package should be pre-tinned with solder, then tacked into place by one of the pins. To solder the tab down to the board place the iron down on the board while resting against the tab, heating both surfaces simultaneously. Apply light pressure to the top of the plastic case until the solder flows around the part and the part is flush with the PCB. If the solder is not flowing around the board you may need a higher wattage iron (generally 25W to 30W is enough).

Initial Startup of Circuit

It is best to initially power up the board by setting the input supply voltage to the lowest operating input voltage 8.0V and set the input supply's current limit to zero. With the input supply off connect up the input supply to V_{in} and GND. Connect a digital volt meter and a load if needed to set the minimum load of the design from V_{out} and GND. Turn on the input supply and slowly turn up the current limit on the input supply. If the voltage starts to rise on the input supply continue increasing the input supply current limit while watching the output voltage. If the current increases on the input supply, but the voltage remains near zero, then there may be a short or a component misplaced on the board. Power down the board and visually inspect for solder bridges and recheck the diode and capacitor polarities. Once the power supply circuit is operational then more extensive testing may include full load testing, transient load and line tests to compare with simulation results.

Load Testing

The setup is the same as the initial startup, except that an additional digital voltmeter is connected between V_{in} and GND, a load is connected between V_{out} and GND and a current meter is connected in series between V_{out} and the load. The load must be able to handle at least rated output power + 50% (7.5 watts for this design). Ideally the load is supplied in the form of a variable load test unit. It can also be done in the form of suitably large power resistors. When using an oscilloscope to measure waveforms on the prototype board, the ground leads of the oscilloscope probes should be as short as possible and the area of the loop formed by the ground lead should be kept to a minimum. This will help reduce ground lead inductance and eliminate EMI noise that is not actually present in the circuit.

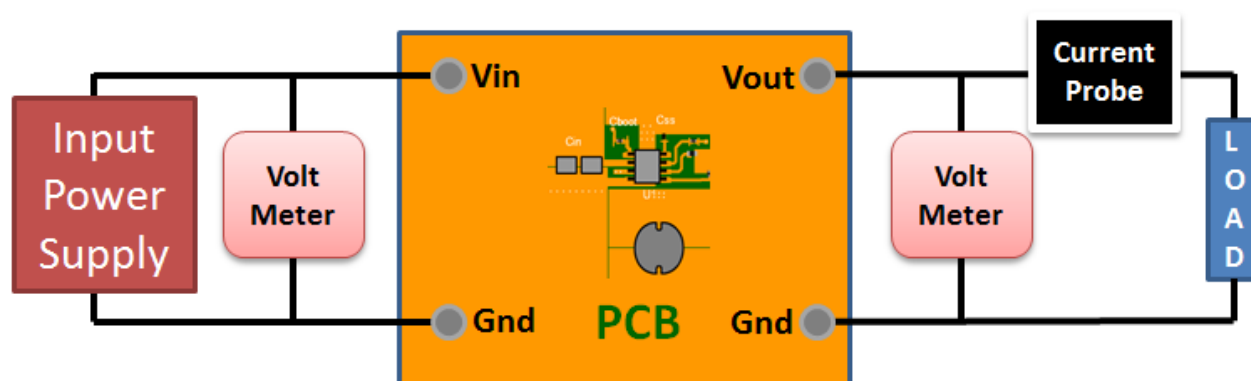

Design Assistance

1. Master key : E96045539EEBA2FE[v1]
2. **TPS54335A** Product Folder : <http://www.ti.com/product/TPS54335A> : contains the data sheet and other resources.

Important Notice and Disclaimer

TI provides technical and reliability data (including datasheets), design resources (including reference designs), application or other design advice, web tools, safety information, and other resources AS IS and with all faults, and disclaims all warranties. These resources are intended for skilled developers designing with TI products. You are solely responsible for (1) selecting the appropriate TI products for your application, (2) designing, validating and testing your application, and (3) ensuring your application meets applicable standards, and any other safety, security, or other requirements.

These resources are subject to change without notice. TI grants you permission to use these resources only for development of an application that uses the TI products described in the resource. Other reproduction and display of these resources is prohibited. No license is granted to any other TI intellectual property right or to any third party intellectual property right. TI disclaims responsibility for, and you will fully indemnify TI and its representatives against, any claims, damages, costs, losses, and liabilities arising out of your use of these resources.

Providing these resources does not expand or otherwise alter TI's applicable Terms of Sale or other applicable terms available either on ti.com or provided in conjunction with TI products.