

WEBENCH® Design Report

 Design : 344 TPS54678RTER
 TPS54678RTER 5V-5.1V to .85V @ 4.5A

Electrical BOM

Name	Manufacturer	Part Number	Properties	Qty	Price	Footprint
Cboot	MuRata	GRM155R71C104KA88D Series= X7R	Cap= 100.0 nF ESR= 1.0 mOhm VDC= 16.0 V IRMS= 0.0 A	1	\$0.01	0402 3 mm ²
Ccomp	MuRata	GRM1555C1H102JA01J Series= C0G/NP0	Cap= 1.0 nF VDC= 50.0 V IRMS= 0.0 A	1	\$0.01	0402 3 mm ²
Ccomp2	Samsung Electro-Mechanics	CL05C130JB5NNNC Series= C0G/NP0	Cap= 13.0 pF VDC= 50.0 V IRMS= 0.0 A	1	\$0.01	0402 3 mm ²
Ccomp3	Samsung Electro-Mechanics	CL21C151JBANNNC Series= C0G/NP0	Cap= 150.0 pF VDC= 50.0 V IRMS= 0.0 A	1	\$0.01	0805 7 mm ²
Cin	MuRata	GRM21BR61A226ME44L Series= X5R	Cap= 22.0 uF ESR= 3.0 mOhm VDC= 10.0 V IRMS= 3.84 A	2	\$0.13	0805 7 mm ²
Cinx	MuRata	GRM155R71A104KA01D Series= X7R	Cap= 100.0 nF ESR= 1.0 mOhm VDC= 10.0 V IRMS= 0.0 A	1	\$0.01	0402 3 mm ²
Cout	MuRata	GRM31CR60J107ME39L Series= X5R	Cap= 100.0 uF ESR= 4.885 mOhm VDC= 6.3 V IRMS= 4.4118 A	2	\$0.34	1206_190 11 mm ²
Css	MuRata	GRM033R71C332KA88D Series= X7R	Cap= 3.3 nF ESR= 1.0 mOhm VDC= 16.0 V IRMS= 0.0 A	1	\$0.01	0201 2 mm ²
L1	NIC Components	NPI31P1R5MTRF	L= 1.5 uH 8.0 mOhm	1	\$0.29	

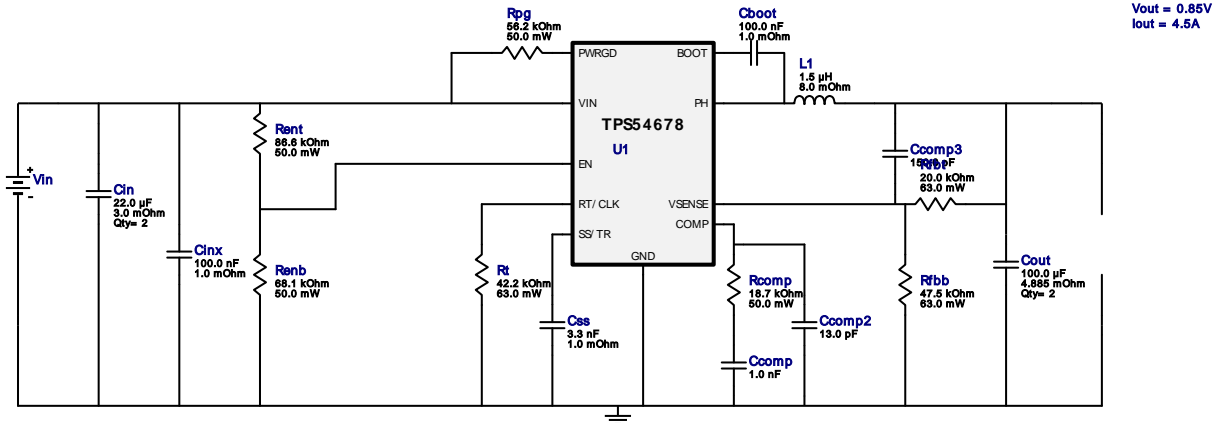
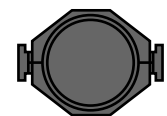

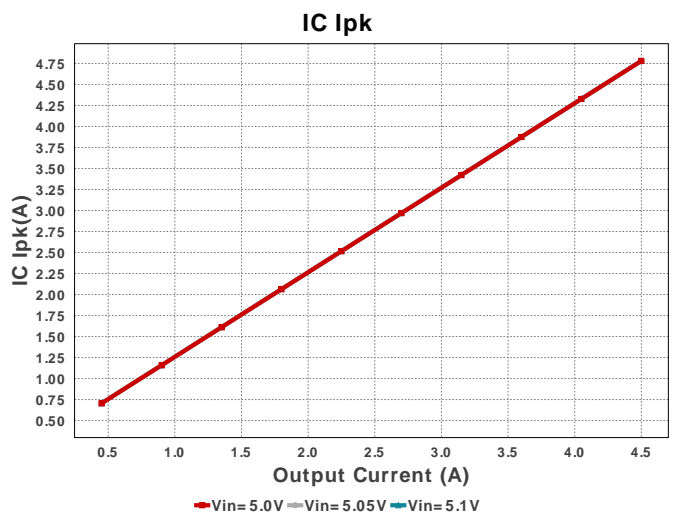
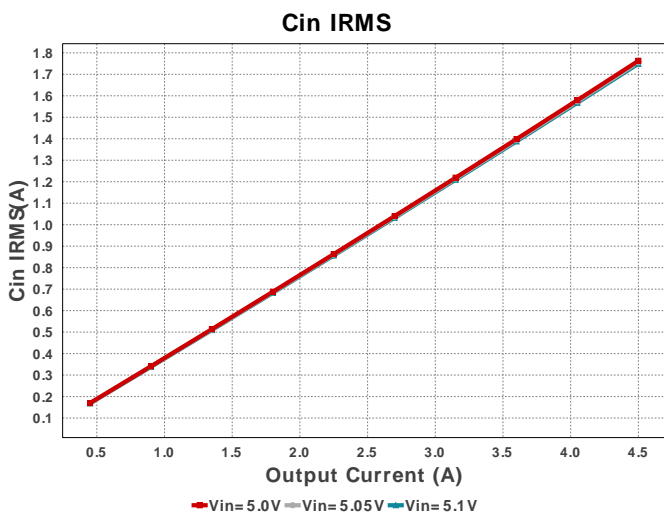
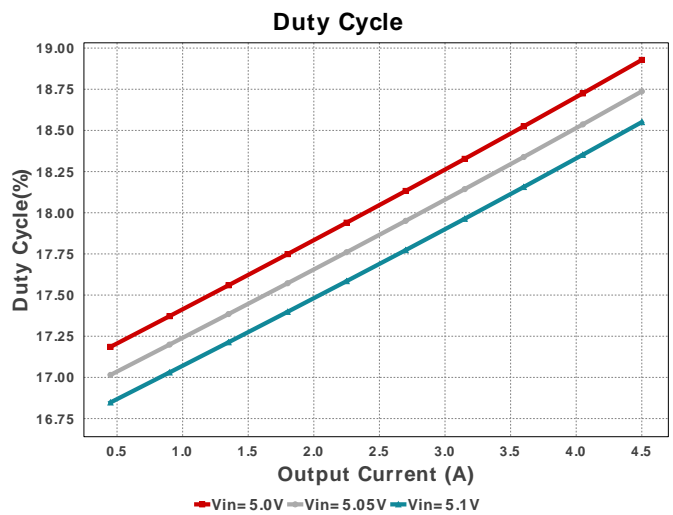
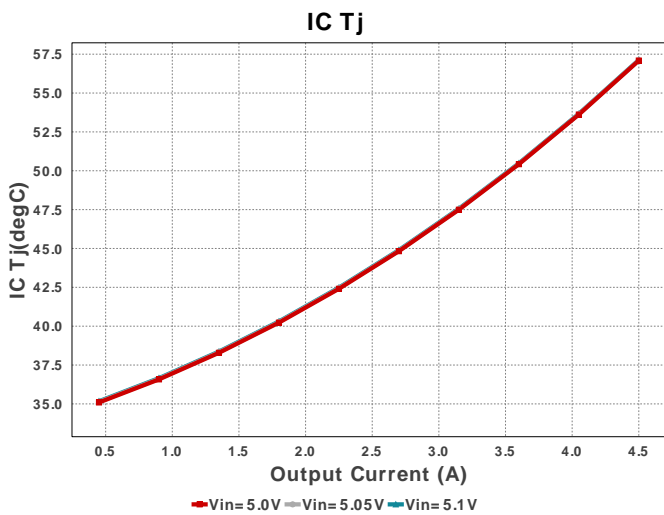
 IND_NPI31P 185 mm²

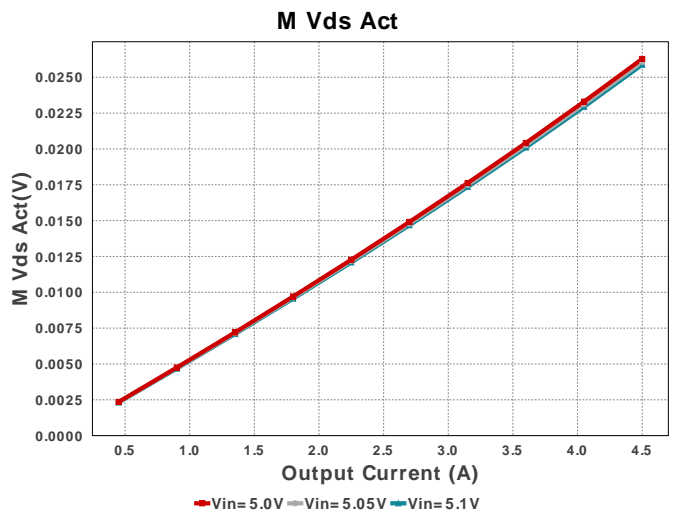
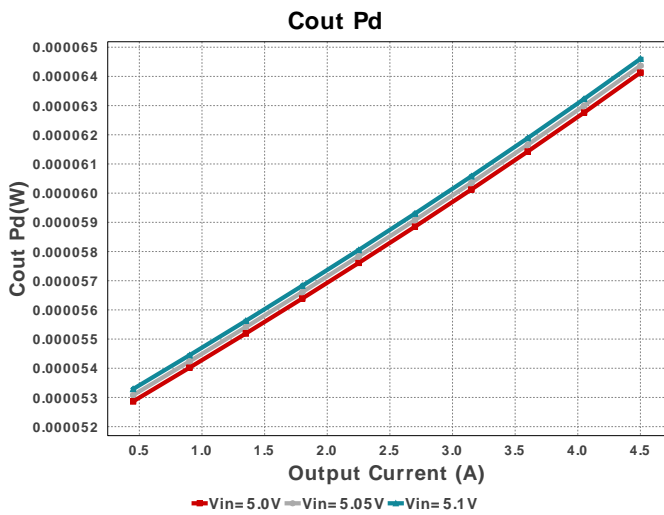
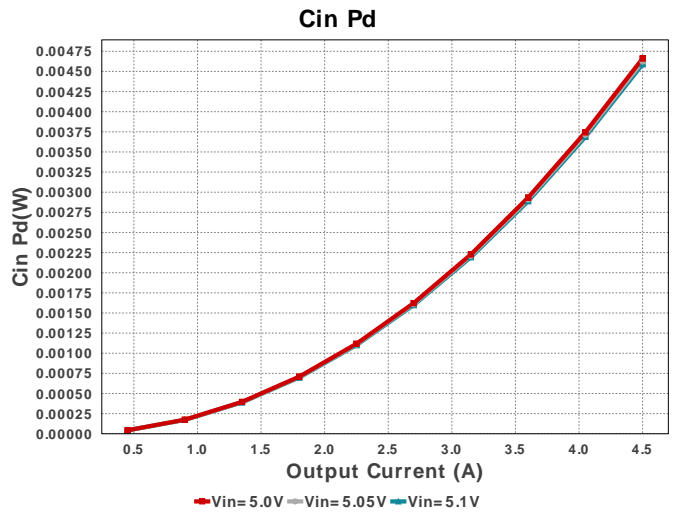
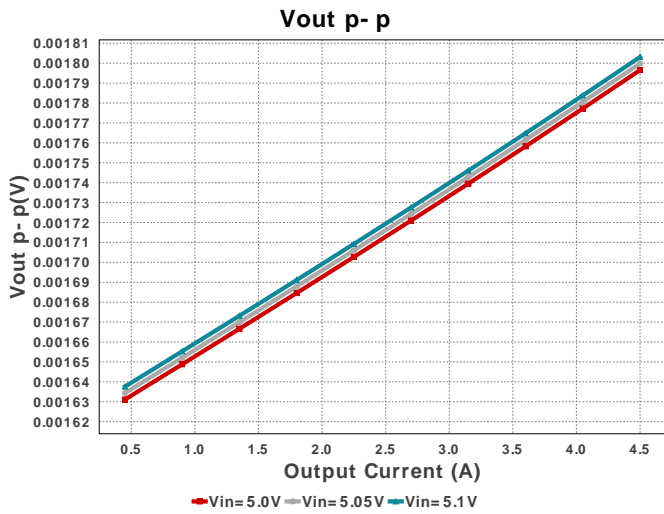
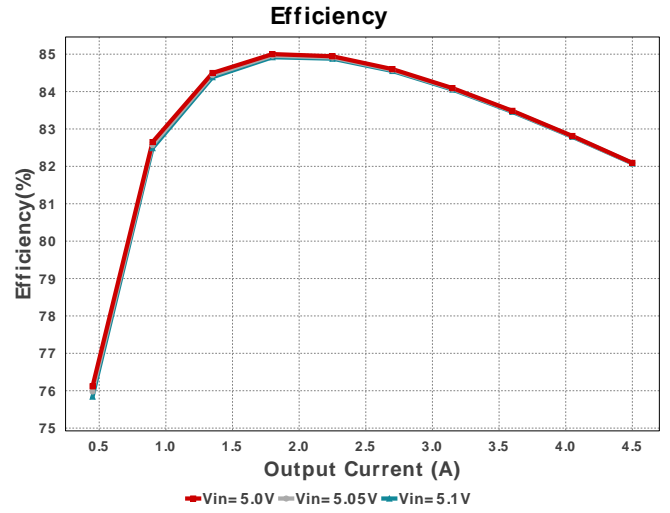
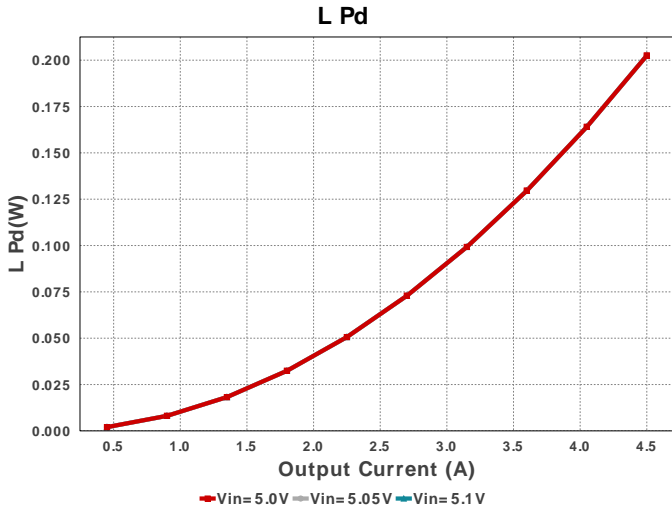
Name	Manufacturer	Part Number	Properties	Qty	Price	Footprint
Rcomp	Yageo	RC0201FR-0718K7L Series= ?	Res= 18.7 kOhm Power= 50.0 mW Tolerance= 1.0%	1	\$0.01	0201 2 mm ²
Renb	Yageo	RC0201FR-7D68K1L Series= ?	Res= 68.1 kOhm Power= 50.0 mW Tolerance= 1.0%	1	\$0.01	0201 2 mm ²
Rent	Yageo	RC0201FR-0786K6L Series= ?	Res= 86.6 kOhm Power= 50.0 mW Tolerance= 1.0%	1	\$0.01	0201 2 mm ²
Rfbb	Vishay-Dale	CRCW040247K5FKED Series= CRCW..e3	Res= 47.5 kOhm Power= 63.0 mW Tolerance= 1.0%	1	\$0.01	0402 3 mm ²
Rfbt	Vishay-Dale	CRCW040220K0FKED Series= CRCW..e3	Res= 20.0 kOhm Power= 63.0 mW Tolerance= 1.0%	1	\$0.01	0402 3 mm ²
Rpg	Yageo	RC0201FR-0756K2L Series= ?	Res= 56.2 kOhm Power= 50.0 mW Tolerance= 1.0%	1	\$0.01	0201 2 mm ²
Rt	Vishay-Dale	CRCW040242K2FKED Series= CRCW..e3	Res= 42.2 kOhm Power= 63.0 mW Tolerance= 1.0%	1	\$0.01	0402 3 mm ²
U1	Texas Instruments	TPS54678RTER	Switcher	1	\$1.14	S-PWQFN-N16 17 mm ²



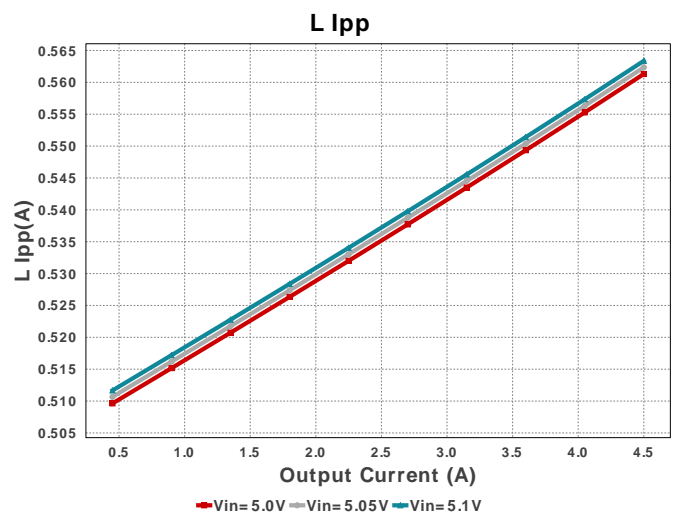
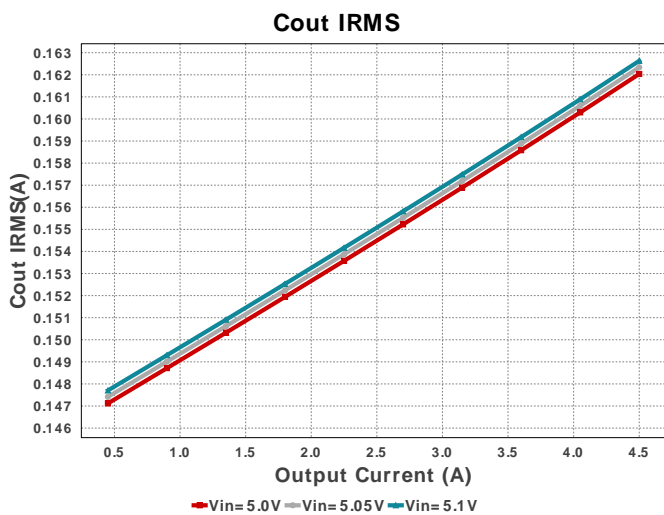
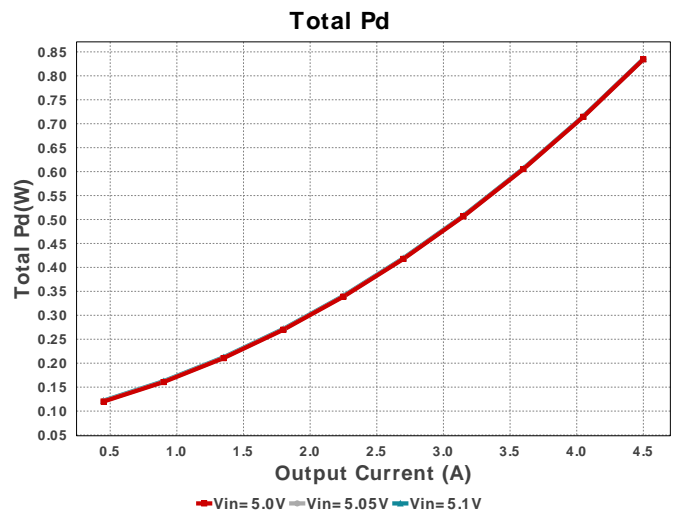
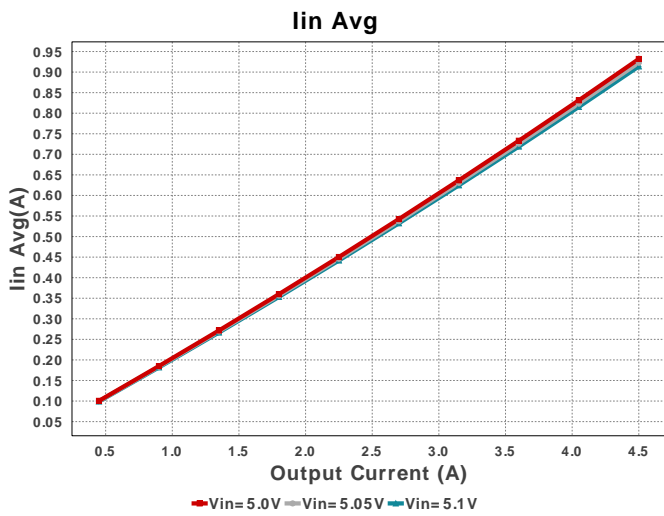
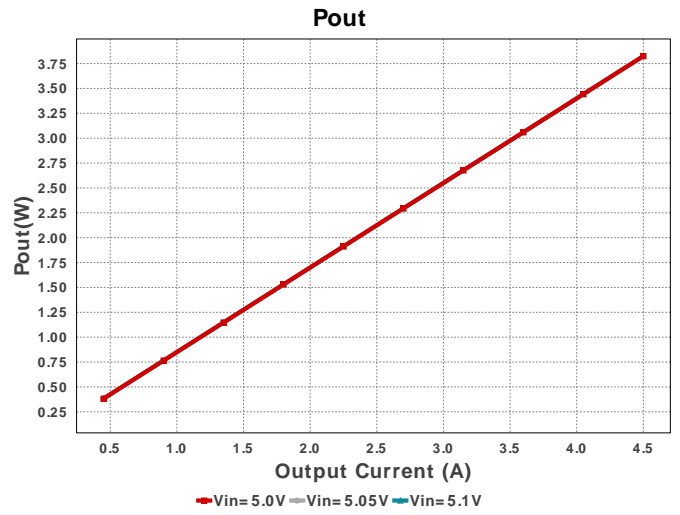
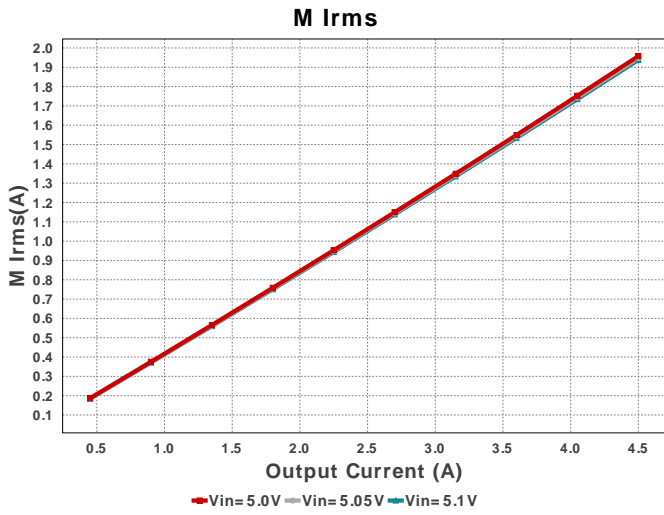

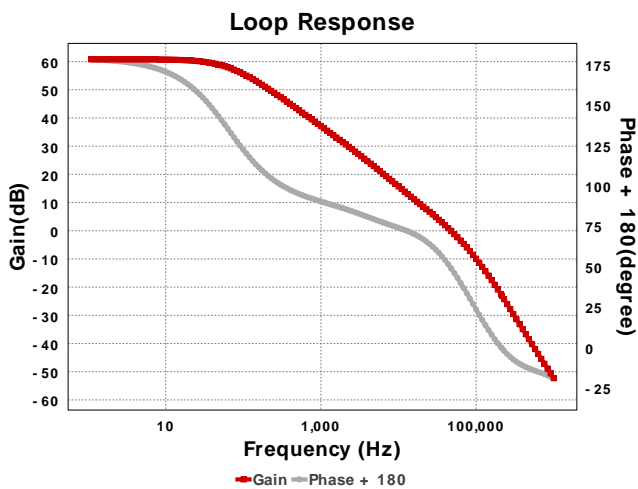
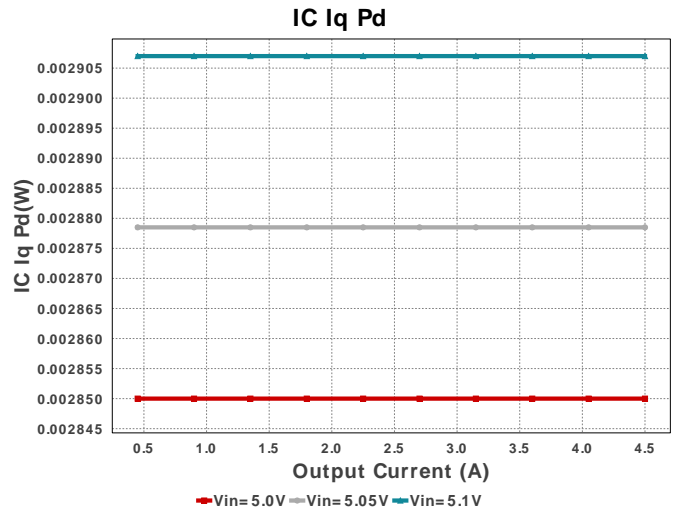
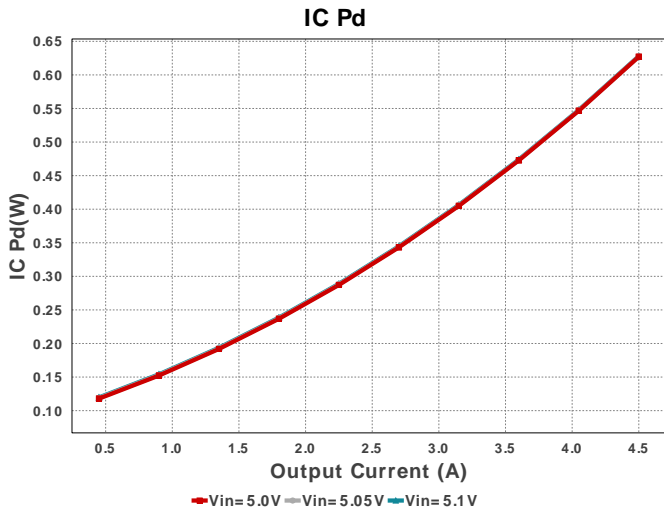



Operating Values

#	Name	Value	Category	Description
1.	BOM Count	19		Total Design BOM count
2.	Total BOM	\$2.504		Total BOM Cost
3.	Cin IRMS	1.749 A	Capacitor	Input capacitor RMS ripple current
4.	Cin Pd	4.589 mW	Capacitor	Input capacitor power dissipation
5.	Cout IRMS	162.631 mA	Capacitor	Output capacitor RMS ripple current
6.	Cout Pd	64.601 μW	Capacitor	Output capacitor power dissipation
7.	IC Ipk	4.782 A	IC	Peak switch current in IC
8.	IC Iq Pd	2.907 mW	IC	IC Iq Pd
9.	IC Pd	628.02 mW	IC	IC power dissipation
10.	IC Tj	57.13 degC	IC	IC junction temperature
11.	IC Tolerance	6.0 mV	IC	IC Feedback Tolerance
12.	ICThetaJA	43.2 degC/W	IC	IC junction-to-ambient thermal resistance
13.	Iin Avg	913.76 mA	IC	Average input current
14.	L Ipp	563.37 mA	Inductor	Peak-to-peak inductor ripple current
15.	L Pd	202.5 mW	Inductor	Inductor power dissipation
16.	M1 Irms	1.938 A	Mosfet	Q Iavg
17.	M Vds Act	25.875 mV	Mosfet	Voltage drop across the MosFET
18.	Cin Pd	4.589 mW	Power	Input capacitor power dissipation
19.	Cout Pd	64.601 μW	Power	Output capacitor power dissipation
20.	IC Pd	628.02 mW	Power	IC power dissipation
21.	L Pd	202.5 mW	Power	Inductor power dissipation
22.	Total Pd	835.15 mW	Power	Total Power Dissipation
23.	Cross Freq	47.367 kHz	System	Bode plot crossover frequency
24.	Duty Cycle	18.55 %	System	Duty cycle
25.	Efficiency	82.079 %	System	Steady state efficiency
26.	FootPrint	275.0 mm ²	System	Total Foot Print Area of BOM components
27.	Frequency	932.953 kHz	System	Switching frequency

#	Name	Value	Category	Description
28.	Gain Marg	-23.135 dB	System Information	Bode Plot Gain Margin
29.	Iout	4.5 A	System Information	Iout operating point
30.	Mode	CCM	System Information	Conduction Mode
31.	Phase Marg	49.806 deg	System Information	Bode Plot Phase Margin
32.	Pout	3.825 W	System Information	Total output power
33.	Vin	5.1 V	System Information	Vin operating point
34.	Vout	850.0 mV	System Information	Operational Output Voltage
35.	Vout Actual	852.632 mV	System Information	Vout Actual calculated based on selected voltage divider resistors
36.	Vout Tolerance	1.605 %	System Information	Vout Tolerance based on IC Tolerance (no load) and voltage divider resistors if applicable
37.	Vout p-p	1.803 mV	System Information	Peak-to-peak output ripple voltage

Design Inputs

Name	Value	Description
Iout	4.5	Maximum Output Current
VinMax	5.1	Maximum input voltage
VinMin	5.0	Minimum input voltage
Vout	850.0 m	Output Voltage
base_pn	TPS54678	Base Product Number
source	DC	Input Source Type
Ta	30.0	Ambient temperature

WEBENCH® Assembly

Component Testing

Some published data on components in datasheets such as Capacitor ESR and Inductor DC resistance is based on conservative values that will guarantee that the components always exceed the specification. For design purposes it is usually better to work with typical values. Since this data is not always available it is a good practice to measure the Capacitance and ESR values of C_{in} and C_{out} , and the inductance and DC resistance of $L1$ before assembly of the board. Any large discrepancies in values should be electrically simulated in WEBENCH to check for instabilities and thermally simulated in WebTHERM to make sure critical temperatures are not exceeded.

Soldering Component to Board

If board assembly is done in house it is best to tack down one terminal of a component on the board then solder the other terminal. For surface mount parts with large tabs, such as the DPAK, the tab on the back of the package should be pre-tinned with solder, then tacked into place by one of the pins. To solder the tab down to the board place the iron down on the board while resting against the tab, heating both surfaces simultaneously. Apply light pressure to the top of the plastic case until the solder flows around the part and the part is flush with the PCB. If the solder is not flowing around the board you may need a higher wattage iron (generally 25W to 30W is enough).

Initial Startup of Circuit

It is best to initially power up the board by setting the input supply voltage to the lowest operating input voltage 5.0V and set the input supply's current limit to zero. With the input supply off connect up the input supply to V_{in} and GND. Connect a digital volt meter and a load if needed to set the minimum load of the design from V_{out} and GND. Turn on the input supply and slowly turn up the current limit on the input supply. If the voltage starts to rise on the input supply continue increasing the input supply current limit while watching the output voltage. If the current increases on the input supply, but the voltage remains near zero, then there may be a short or a component misplaced on the board. Power down the board and visually inspect for solder bridges and recheck the diode and capacitor polarities. Once the power supply circuit is operational then more extensive testing may include full load testing, transient load and line tests to compare with simulation results.

Load Testing

The setup is the same as the initial startup, except that an additional digital voltmeter is connected between V_{in} and GND, a load is connected between V_{out} and GND and a current meter is connected in series between V_{out} and the load. The load must be able to handle at least rated output power + 50% (7.5 watts for this design). Ideally the load is supplied in the form of a variable load test unit. It can also be done in the form of suitably large power resistors. When using an oscilloscope to measure waveforms on the prototype board, the ground leads of the oscilloscope probes should be as short as possible and the area of the loop formed by the ground lead should be kept to a minimum. This will help reduce ground lead inductance and eliminate EMI noise that is not actually present in the circuit.



WEBENCH® Electrical Simulation Report

Design Id = 344

sim_id = 2

Simulation Type = Load Transient

VinMin = 5.0V
VinMax = 5.1V

Vout = 0.85V
Iout = 4.5A

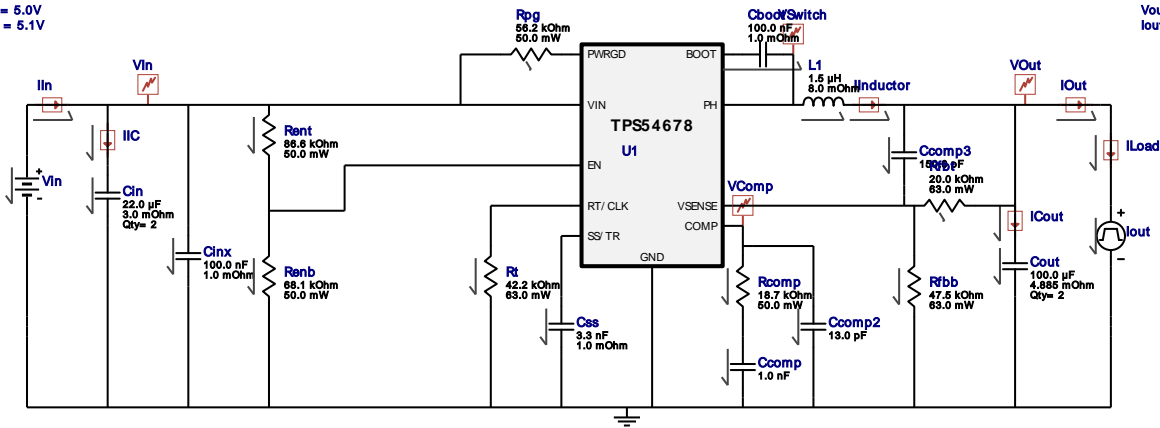

Simulation Parameters

#	Name	Parameter Name	Description	Values
1.	Css	IC	Initial Voltage	0.65 V
2.	Cout	IC	no description	0.85 V
3.	L1	IC	Initial Current	Iout A
4.	Iout	signal_type	Signal type	PULSE
		I1	Initial Load Current	4.5 A
		I2	Minimum Load Current	0.45 A
		Td	Time Delay	9.149745773821278E-4 s
		Tr	Rise Time	50u s
		Tf	Fall Time	50u s
		Pw	Pulse Width	5.201140992919474E-4 s

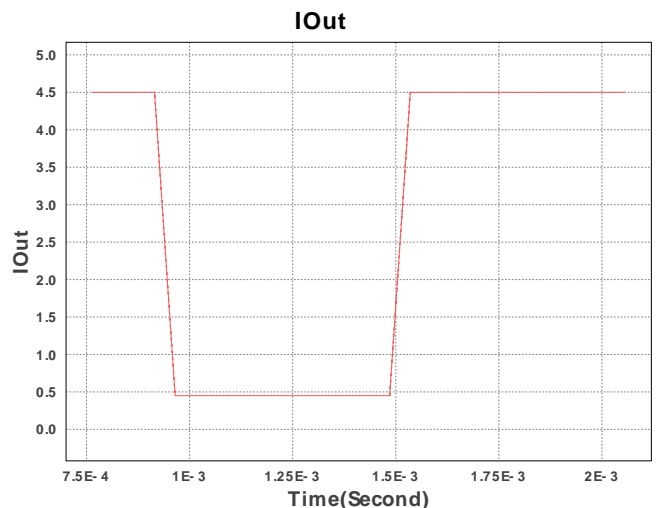
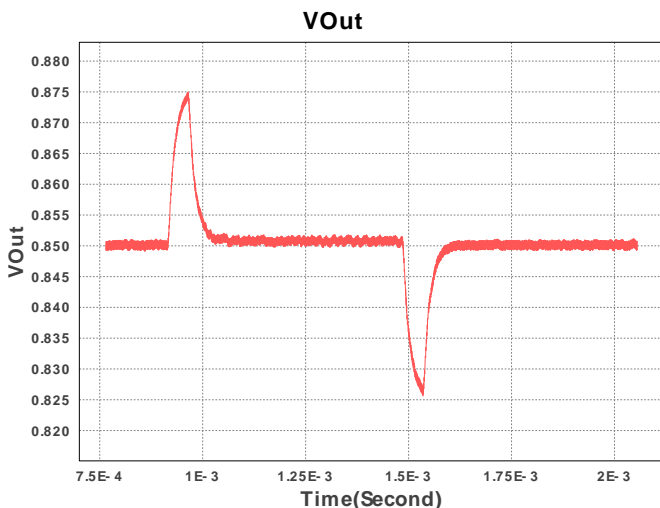

Design Assistance

1. Master key : 70828AA8AD4E7637[v1]

2. **TPS54678** Product Folder : <http://www.ti.com/product/TPS54678> : contains the data sheet and other resources.

Important Notice and Disclaimer

TI provides technical and reliability data (including datasheets), design resources (including reference designs), application or other design advice, web tools, safety information, and other resources AS IS and with all faults, and disclaims all warranties. These resources are intended for skilled developers designing with TI products. You are solely responsible for (1) selecting the appropriate TI products for your application, (2) designing, validating and testing your application, and (3) ensuring your application meets applicable standards, and any other safety, security, or other requirements.

These resources are subject to change without notice. TI grants you permission to use these resources only for development of an application that uses the TI products described in the resource. Other reproduction and display of these resources is prohibited. No license is granted to any other TI intellectual property right or to any third party intellectual property right. TI disclaims responsibility for, and you will fully indemnify TI and its representatives against, any claims, damages, costs, losses, and liabilities arising out of your use of these resources.

Providing these resources does not expand or otherwise alter TI's applicable Terms of Sale or other applicable terms available either on ti.com or provided in conjunction with TI products.