

WEBENCH® Design Report

Design : 38 LM5023MMX-2/NOPB
 LM5023MMX-2/NOPB 85V-484V to 15.00V @ 2.5A

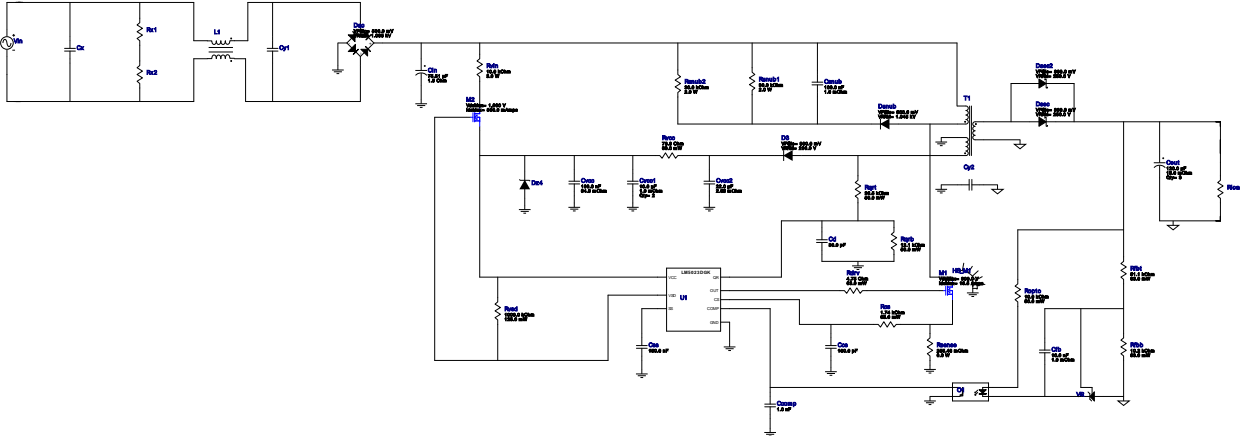

1. The EMI filter shown in the schematic is a placeholder. It has not yet been designed for the application.

Design Alerts













Component Selection Information

Click on the transformer symbol in the schematic and select "Explore Transformer Core/Bobbin Selection" to design using specific transformer cores and bobbin.

Electrical BOM

Name	Manufacturer	Part Number	Properties	Qty	Price	Footprint
Ccomp	MuRata	GRM1555C1H102JA01J Series= C0G/NP0	Cap= 1.0 nF VDC= 50.0 V IRMS= 0.0 A	1	\$0.01	0402 3 mm ²
Ccs	Samsung Electro-Mechanics	CL21C101JBANNNC Series= C0G/NP0	Cap= 100.0 pF VDC= 50.0 V IRMS= 0.0 A	1	\$0.01	0805 7 mm ²
Cd	Samsung Electro-Mechanics	CL21C300JBANNNC Series= C0G/NP0	Cap= 30.0 pF VDC= 50.0 V IRMS= 0.0 A	1	\$0.01	0805 7 mm ²
Cfb	MuRata	GRM033R70J103KA01D Series= X7R	Cap= 10.0 nF ESR= 1.0 mOhm VDC= 6.3 V IRMS= 0.0 A	1	\$0.01	0201 2 mm ²
Cin	CUSTOM	CUSTOM Series= ?	Cap= 75.51 uF ESR= 1.5005 Ohm VDC= 718.7 V IRMS= 1.03031 A	1	NA	CUSTOM 0 mm ²
Cout	Panasonic	35SEPF120M Series= SEPF	Cap= 120.0 uF ESR= 18.0 mOhm VDC= 35.0 V IRMS= 4.4 A	3	\$0.69	SEPF_F13 144 mm ²
Csnub	MuRata	GRM43DR72J104KW01L Series= X7R	Cap= 100.0 nF ESR= 1.0 mOhm VDC= 630.0 V IRMS= 0.0 A	1	\$0.53	1812 23 mm ²
Css	Panasonic	EPCU1C154MA5 Series= EPCU(A)	Cap= 150.0 nF VDC= 16.0 V IRMS= 0.0 A	1	\$0.17	1206 11 mm ²

Name	Manufacturer	Part Number	Properties	Qty	Price	Footprint
Cvcc	Kemet	C0805C104M5RACTU Series= X7R	Cap= 100.0 nF ESR= 64.0 mOhm VDC= 50.0 V IRMS= 1.64 A	1	\$0.01	 0805 7 mm ²
Cvcc1	TDK	C3225X5R1H106K250AB Series= X5R	Cap= 10.0 uF ESR= 1.0 mOhm VDC= 50.0 V IRMS= 5.0 A	2	\$0.46	 1210_280 15 mm ²
Cvcc2	TDK	C2012X5R1V226M125AC Series= X5R	Cap= 22.0 uF ESR= 2.05 mOhm VDC= 35.0 V IRMS= 4.5559 A	1	\$0.33	 0805 7 mm ²
D3	Fairchild Semiconductor	S320	VF@Io= 900.0 mV VRRM= 200.0 V	1	\$0.25	 SMB 44 mm ²
Dac	CUSTOM	CUSTOM	VF@Io= 500.0 mV VRRM= 1.095 kV	1	NA	CUSTOM 0 mm ²
Dsec	ON Semiconductor	MBRB40250TG	VF@Io= 860.0 mV VRRM= 250.0 V	1	\$0.94	 DDPAK 210 mm ²
Dsec2	ON Semiconductor	MBRB40250TG	VF@Io= 860.0 mV VRRM= 250.0 V	1	\$0.94	 DDPAK 210 mm ²
Dsnub	CUSTOM	CUSTOM	VF@Io= 500.0 mV VRRM= 1.045 kV	1	NA	CUSTOM 0 mm ²
Dz4	ON Semiconductor	MMBZ5244BLT1G	Zener	1	\$0.02	 SOT-23 14 mm ²
HS_M1	Aavid	576602B00000G	Heatsink	1	\$0.59	 576602 403 mm ²
M1	STMicroelectronics	STP21N90K5	VdsMax= 900.0 V IdsMax= 18.5 Amps	1	NA	TO-220 0 mm ²
M2	IXYS	IXTA08N100D2	VdsMax= 1,000.0 V IdsMax= 800.0 mAmps	1	\$0.80	 DDPAK 210 mm ²
O1	Fairchild Semiconductor	FOD817A	Optocoupler	1	\$0.11	 DIP-4 71 mm ²
Rcs	Vishay-Dale	CRCW04021K74FKED Series= CRCW..e3	Res= 1.74 kOhm Power= 63.0 mW Tolerance= 1.0%	1	\$0.01	 0402 3 mm ²
Rdrv	Vishay-Dale	CRCW04024R75FKED Series= CRCW..e3	Res= 4.75 Ohm Power= 63.0 mW Tolerance= 1.0%	1	\$0.01	 0402 3 mm ²

Name	Manufacturer	Part Number	Properties	Qty	Price	Footprint
Rfbb	Vishay-Dale	CRCW040210K2FKED Series= CRCW..e3	Res= 10.2 kOhm Power= 63.0 mW Tolerance= 1.0%	1	\$0.01	 0402 3 mm ²
Rfbt	Vishay-Dale	CRCW040251K1FKED Series= CRCW..e3	Res= 51.1 kOhm Power= 63.0 mW Tolerance= 1.0%	1	\$0.01	 0402 3 mm ²
Ropto	Yageo	RC0201FR-0710KL Series= ?	Res= 10.0 kOhm Power= 50.0 mW Tolerance= 1.0%	1	\$0.01	 0201 2 mm ²
Rqrb	Yageo	RC0201FR-0712K1L Series= ?	Res= 12.1 kOhm Power= 50.0 mW Tolerance= 1.0%	1	\$0.01	 0201 2 mm ²
Rqrt	Yageo	RC0201FR-0736K5L Series= ?	Res= 36.5 kOhm Power= 50.0 mW Tolerance= 1.0%	1	\$0.01	 0201 2 mm ²
Rsense	CUSTOM	CUSTOM Series= ?	Res= 255.48 mOhm Power= 0.0 W Tolerance= 0.0%	1	NA	CUSTOM 0 mm ²
Rsub1	Vishay-Bcomponents	PR02000203002JR500 Series= ?	Res= 30.0 kOhm Power= 2.0 W Tolerance= 5.0%	1	\$0.05	 PR02 117 mm ²
Rsub2	Vishay-Bcomponents	PR02000203002JR500 Series= ?	Res= 30.0 kOhm Power= 2.0 W Tolerance= 5.0%	1	\$0.05	 PR02 117 mm ²
Rvcc	Vishay-Dale	CRCW040276R8FKED Series= CRCW..e3	Res= 76.8 Ohm Power= 63.0 mW Tolerance= 1.0%	1	\$0.01	 0402 3 mm ²
Rvin	Vishay-Bcomponents	PR03000201002JAC00 Series= ?	Res= 10.0 kOhm Power= 3.0 W Tolerance= 5.0%	1	\$0.17	 PR03 197 mm ²
Rvsd	Vishay-Dale	CRCW08051M00FKEA Series= CRCW..e3	Res= 1000.0 kOhm Power= 125.0 mW Tolerance= 1.0%	1	\$0.01	 0805 7 mm ²
T1	Core=TDK , CoilFormer=TDK	Core=B65847A0000R087 , CoilFormer=B65848D1010D001	Lp= 817.0 μH Turns Ratio(Nas)= 7:9 Turns Ratio(Nps)= 68:9 Npri= 68.0 Naux= 7.0 Nsec= 9.0	1	\$3.20	 TDK_B65839 714 mm ²
U1	Texas Instruments	LM5023MMX-2/NOPB	Switcher	1	\$0.42	 DGK0008A 24 mm ²
VR	Texas Instruments	TL432IDBVR	Voltage References	1	NA	 R-PDSO-G3 16 mm ²

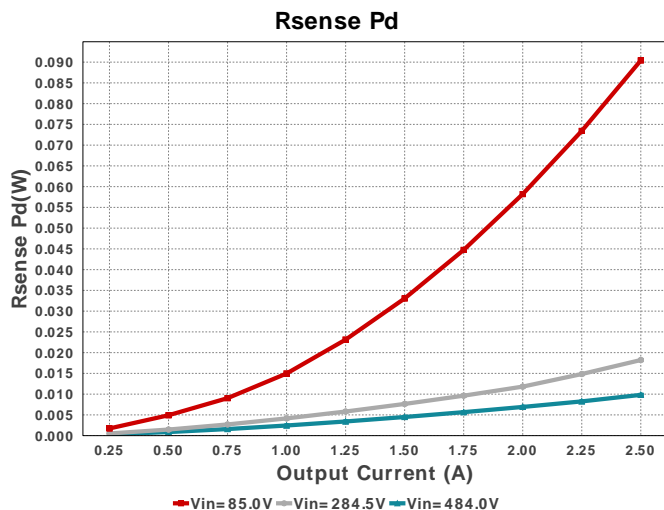
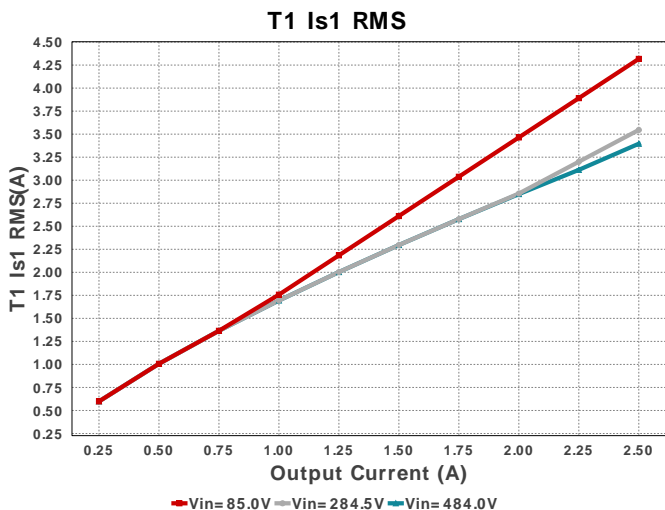
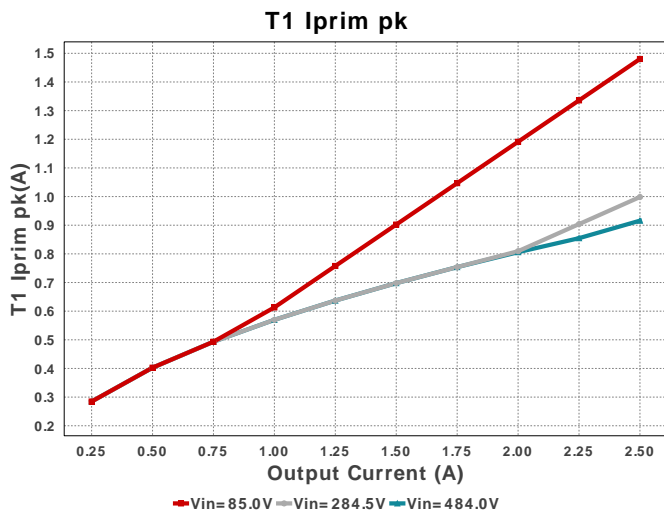
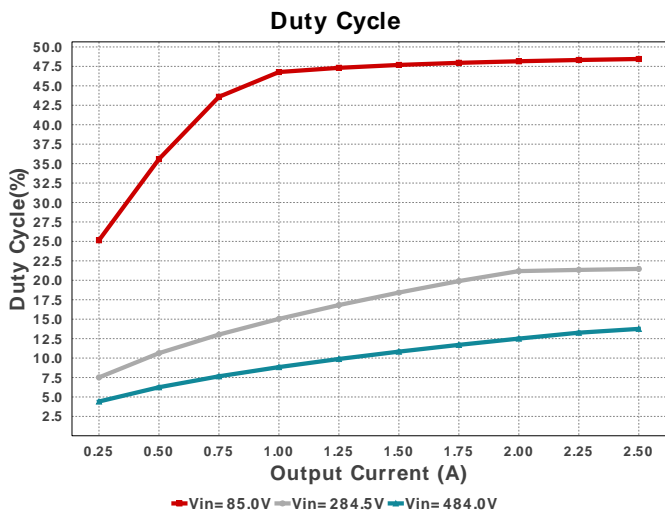
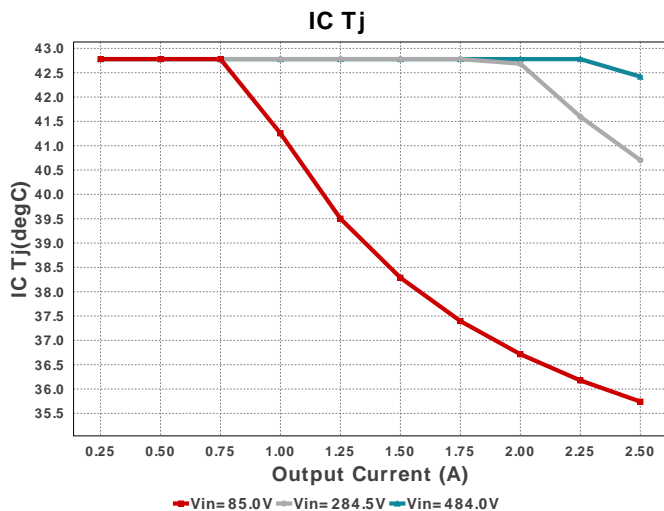
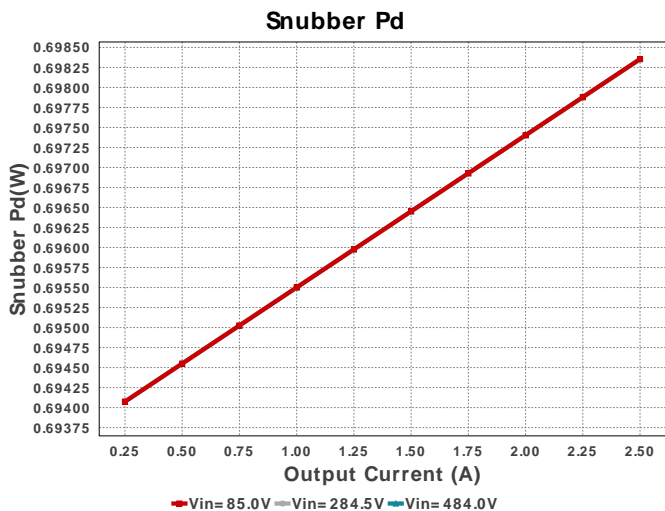

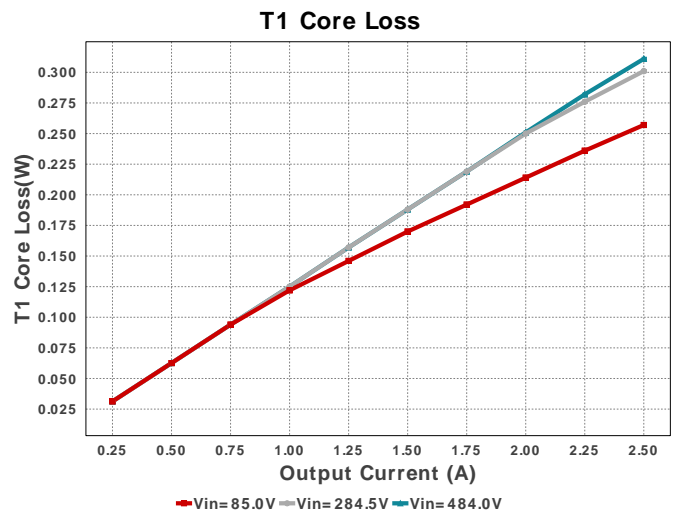
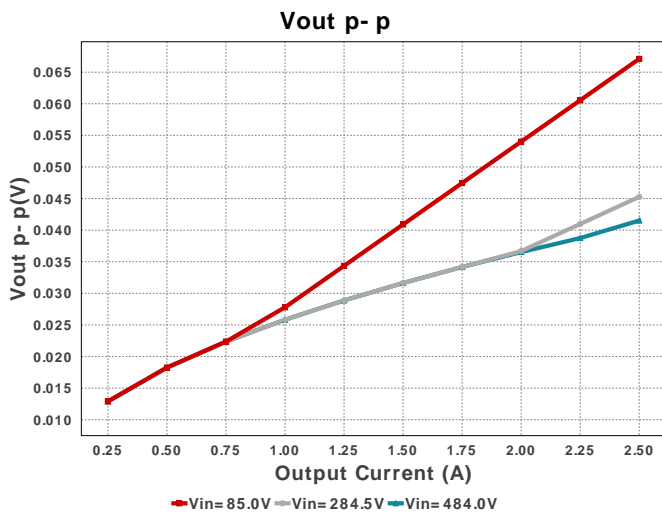
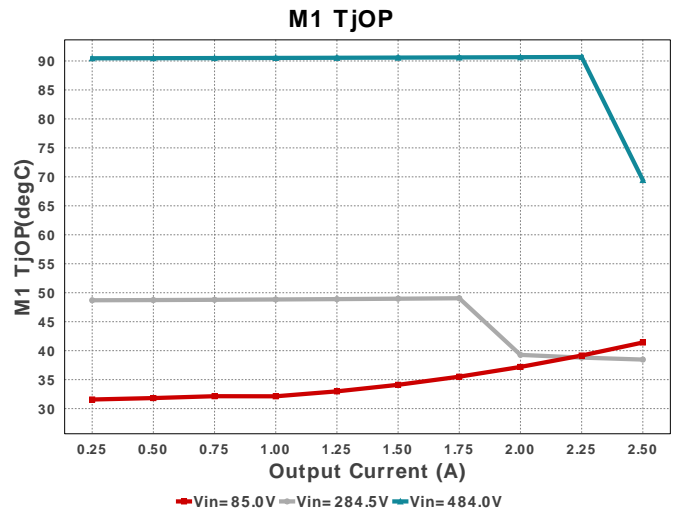
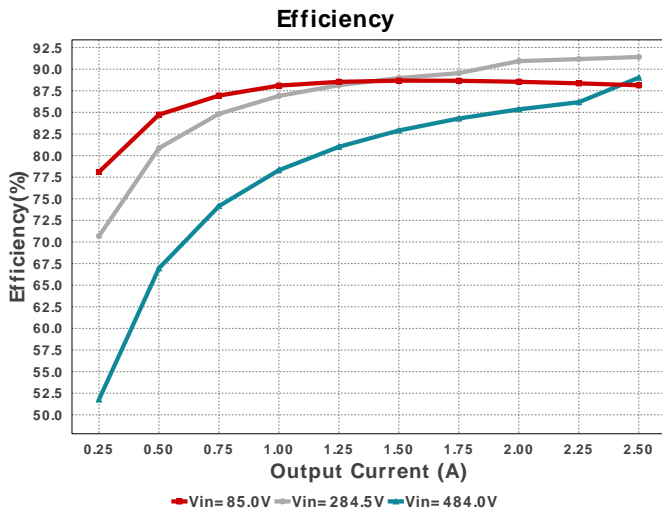
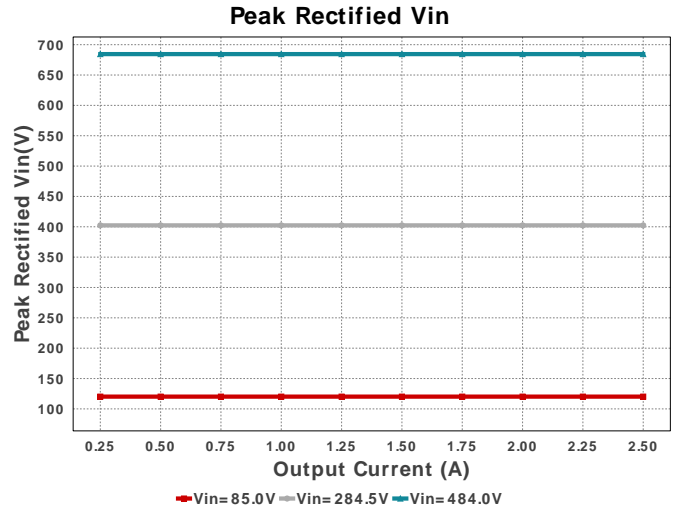
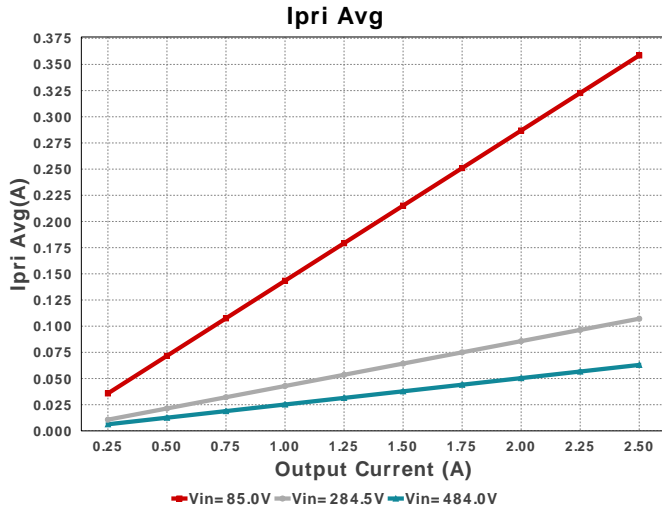

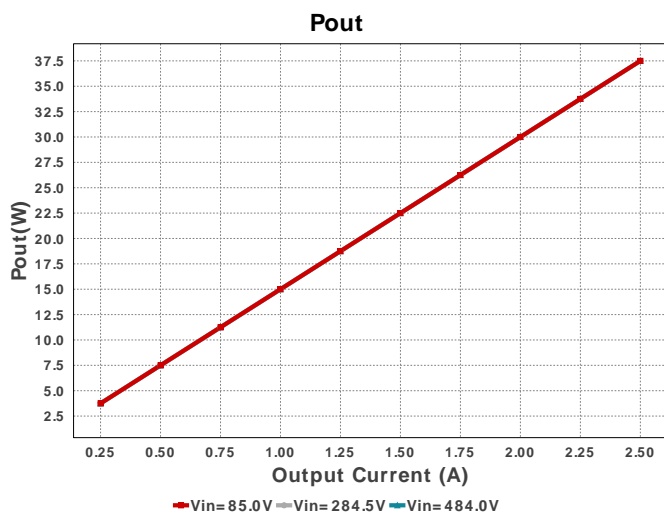
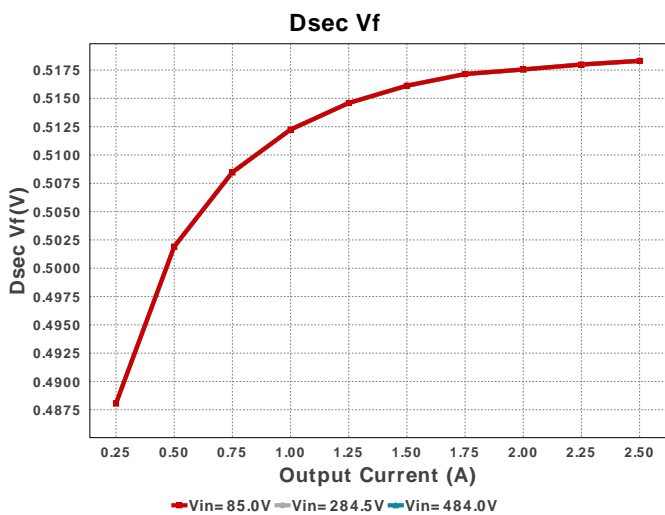
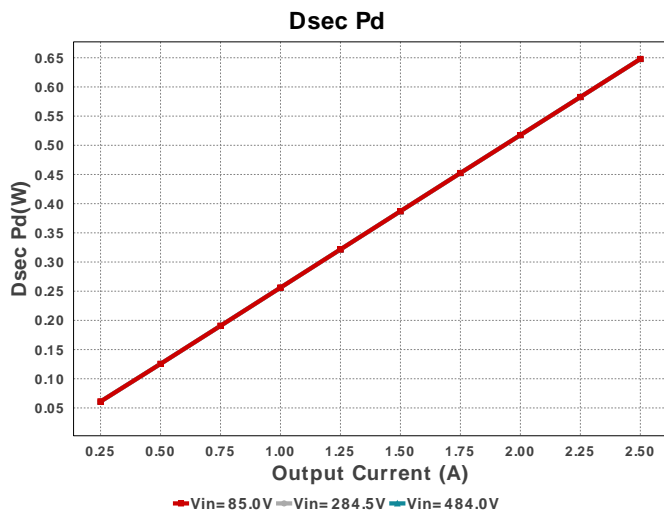
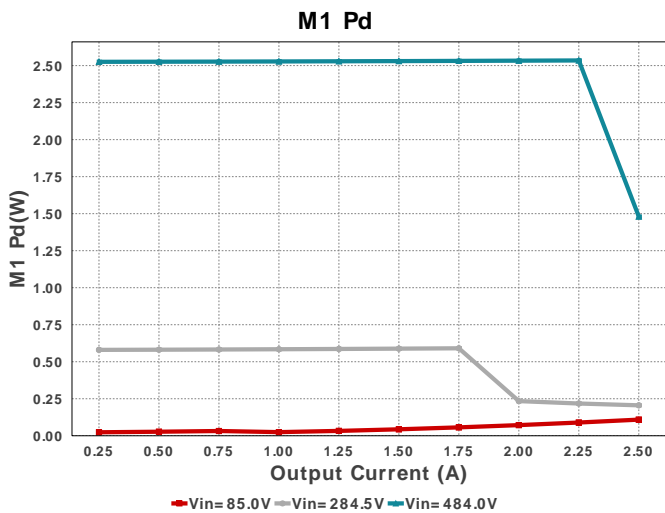
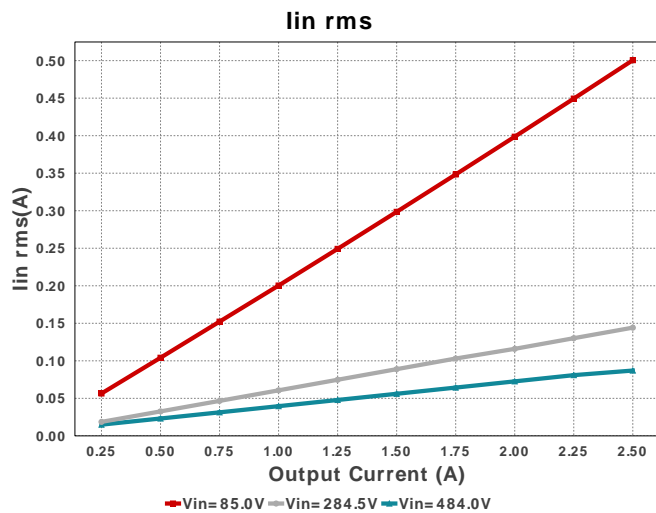
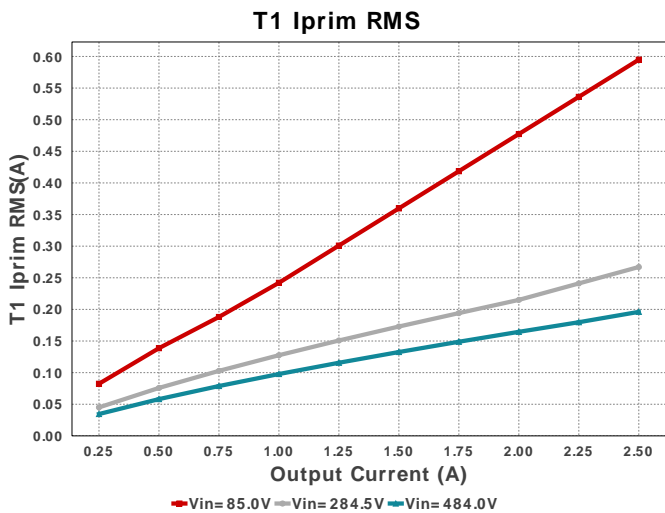

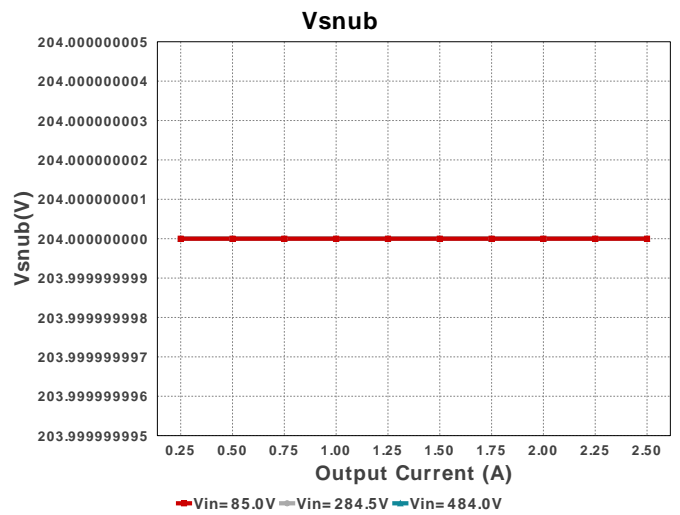
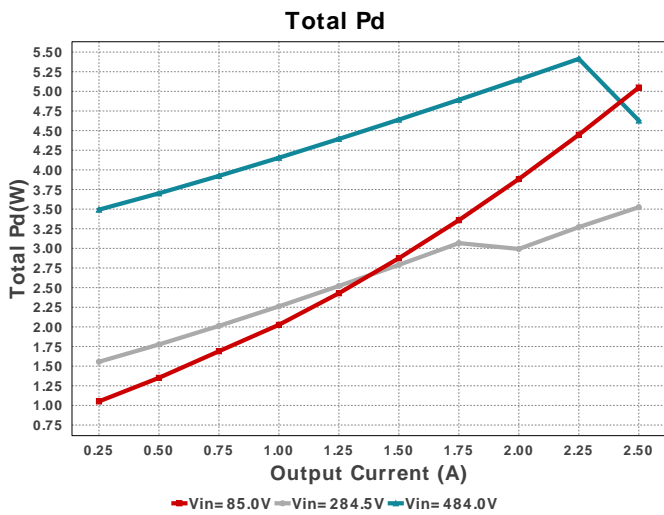
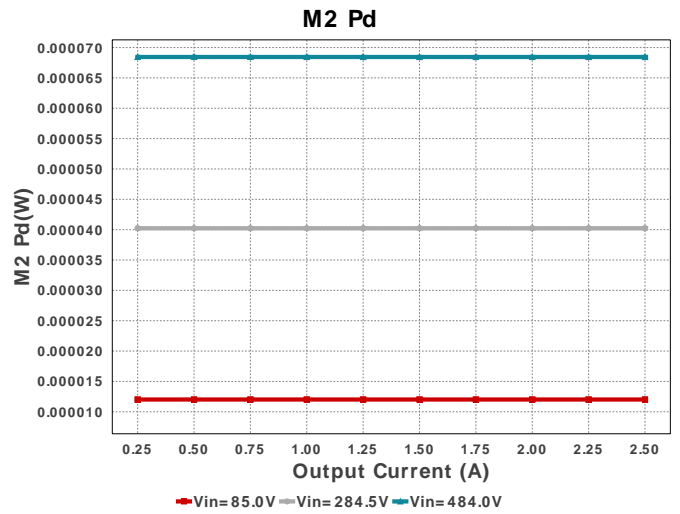
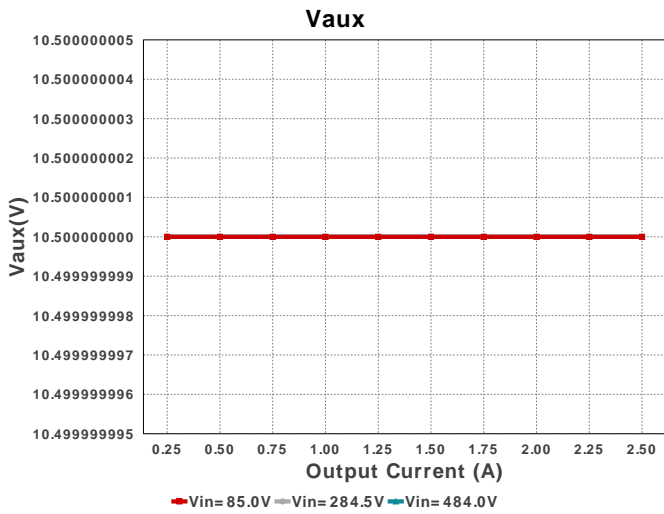
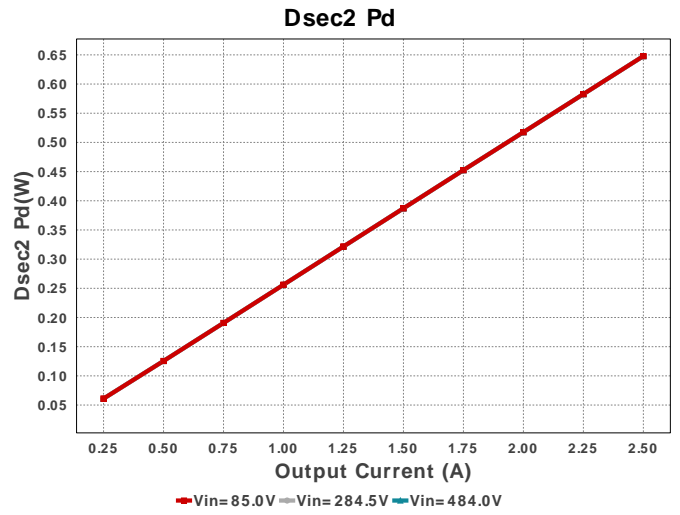
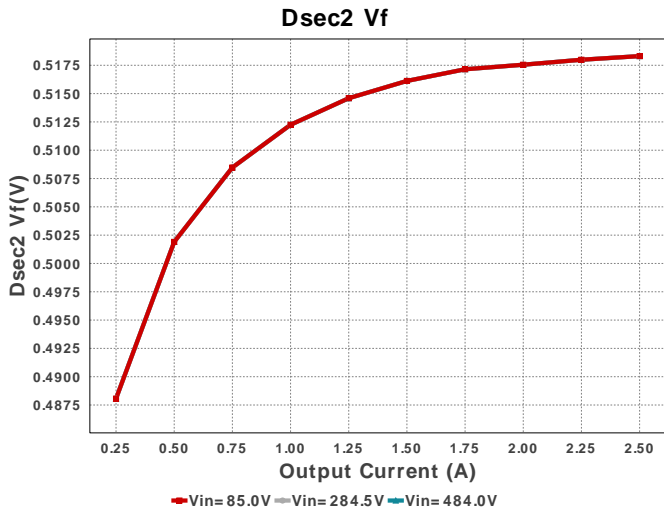

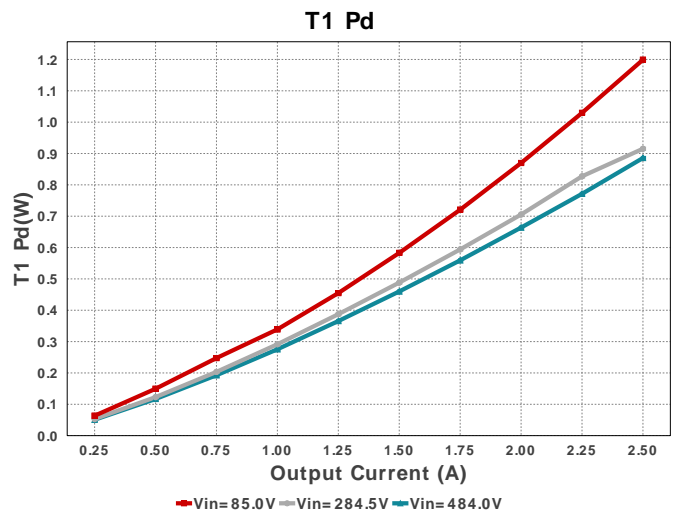
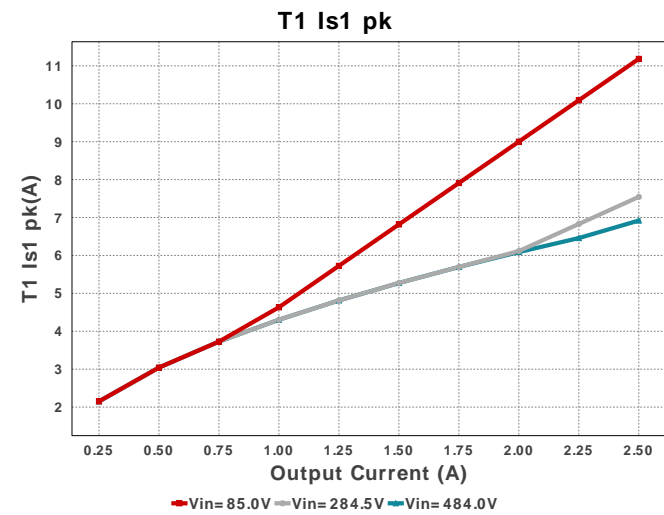
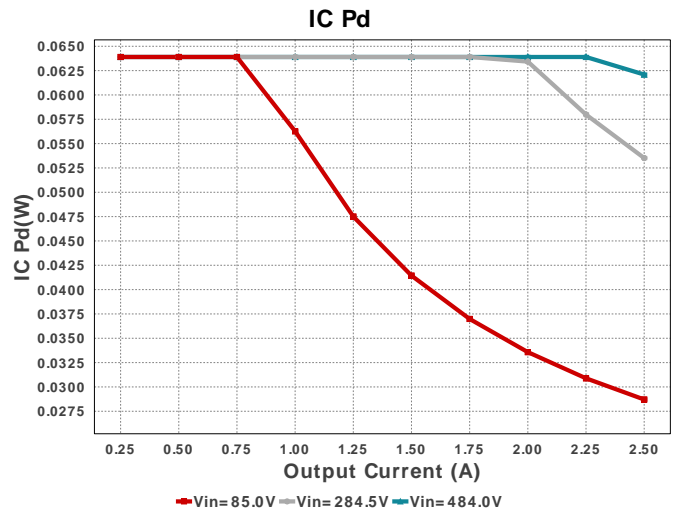
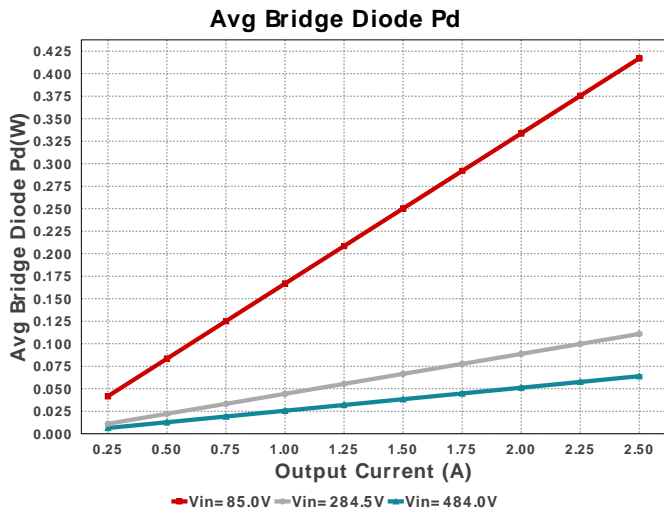
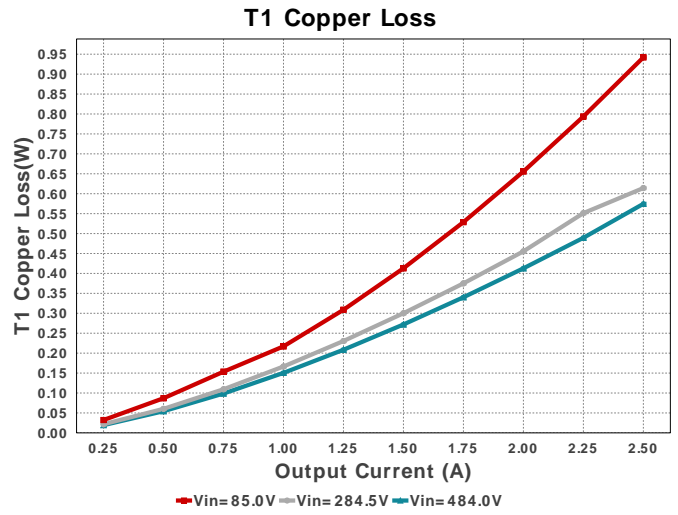
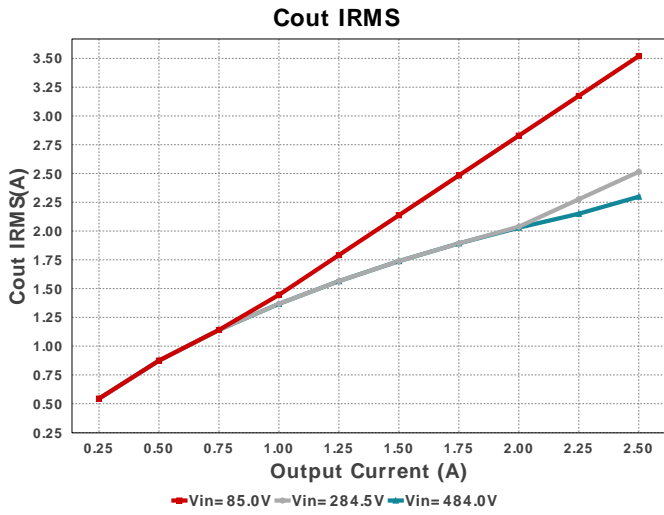

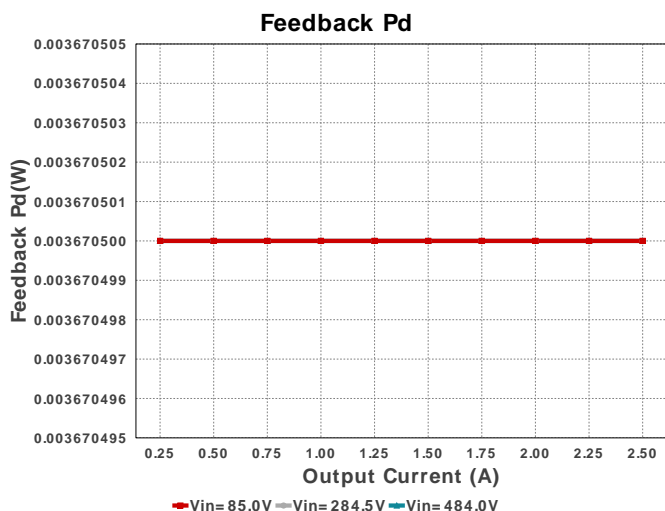

Operating Values

#	Name	Value	Category	Description
1.	BOM Count	40		Total Design BOM count
2.	Total BOM	NA		Total BOM Cost
3.	Cout IRMS	3.52 A	Capacitor	Output capacitor RMS ripple current
4.	Avg Bridge Diode Pd	417.06 mW	Diode	Average Power Dissipation in the Bridge Diode over the AC Line Period
5.	Dsec Pd	647.89 mW	Diode	Secondary Diode Power Dissipation
6.	Dsec Vf	518.311 mV	Diode	Effective Forward Voltage Drop at the Operating Current
7.	Dsec2 Pd	647.89 mW	Diode	Secondary Diode Power Dissipation
8.	Dsec2 Vf	518.311 mV	Diode	Effective Forward Voltage Drop at the Operating Current
9.	IC Pd	28.708 mW	IC	IC power dissipation
10.	IC Tj	35.742 degC	IC	IC junction temperature
11.	ICThetaJA	200.0 degC/W	IC	IC junction-to-ambient thermal resistance
12.	M1 Pd	108.93 mW	Mosfet	M1 MOSFET total power dissipation
13.	M1 TjOP	41.409 degC	Mosfet	M1 MOSFET junction temperature
14.	M2 Pd	12.021 μ W	Mosfet	M2 MOSFET total power dissipation
15.	Avg Bridge Diode Pd	417.06 mW	Power	Average Power Dissipation in the Bridge Diode over the AC Line Period
16.	Dsec Pd	647.89 mW	Power	Secondary Diode Power Dissipation
17.	Dsec2 Pd	647.89 mW	Power	Secondary Diode Power Dissipation
18.	Feedback Pd	3.67 mW	Power	Power Dissipation in Feedback Resistors
19.	IC Pd	28.708 mW	Power	IC power dissipation
20.	M1 Pd	108.93 mW	Power	M1 MOSFET total power dissipation
21.	M2 Pd	12.021 μ W	Power	M2 MOSFET total power dissipation
22.	Rsense Pd	90.408 mW	Power	LED Current Rsns Power Dissipation
23.	Snubber Pd	698.354 mW	Power	Snubber Power Dissipation
24.	T1 Copper Loss	942.05 mW	Power	Transformer Copper Loss Power Dissipation
25.	T1 Core Loss	257.0 mW	Power	Transformer Core Loss Power Dissipation
26.	T1 Pd	1.199 W	Power	Estimated Losses in Transformer
27.	Total Pd	5.049 W	Power	Total Power Dissipation
28.	Feedback Pd	3.67 mW	Resistor	Power Dissipation in Feedback Resistors
29.	Rsense Pd	90.408 mW	Resistor	LED Current Rsns Power Dissipation
30.	Duty Cycle	48.451 %	System	Duty cycle
31.	Efficiency	88.134 %	System	Steady state efficiency
32.	FootPrint	3.017 k mm ²	System	Total Foot Print Area of BOM components
33.	Frequency	48.159 kHz	System	Switching frequency
34.	Iin rms	500.57 mA	System	RMS Input Current
35.	Iout	2.5 A	System	Iout operating point
36.	Mode	TM	System	Conduction Mode
37.	Peak Rectified Vin	120.207 V	System	Peak voltage seen at rectified input
38.	Pout	37.5 W	System	Total output power
39.	Vin_RMS	85.0 V	System	Vin operating point
40.	Vout	15.0 V	System	Operational Output Voltage

#	Name	Value	Category	Description
41.	Vout Actual	14.994 V	System Information	Vout Actual calculated based on selected voltage divider resistors
42.	Vout Tolerance	2.01 %	System Information	Vout Tolerance based on IC Tolerance (no load) and voltage divider resistors if applicable
43.	Vout p-p	67.105 mV	System Information	Peak-to-peak output ripple voltage
44.	Vsnub	204.0 V	System Information	Voltage Across the Snubber
45.	Ipri Avg	358.602 mA	Transformer	Average Current in Primary Winding over the complete Switching Period
46.	T1 Copper Loss	942.05 mW	Transformer	Transformer Copper Loss Power Dissipation
47.	T1 Core Loss	257.0 mW	Transformer	Transformer Core Loss Power Dissipation
48.	T1 Iprim RMS	594.879 mA	Transformer	Transformer Primary RMS Current
49.	T1 Iprim pk	1.48 A	Transformer	Transformer Primary Peak Current
50.	T1 Is1 RMS	4.317 A	Transformer	Transformer Secondary1 RMS Current
51.	T1 Is1 pk	11.184 A	Transformer	Transformer Secondary1 Peak Current
52.	T1 Pd	1.199 W	Transformer	Estimated Losses in Transformer
53.	Vaux	10.5 V	Transformer	Auxiliary Voltage

Design Inputs

Name	Value	Description
Iout	2.5	Maximum Output Current
VinMax	484.0	Maximum input voltage
VinMin	85.0	Minimum input voltage
Vout	15.0	Output Voltage
acFrequency	50.0	AC Frequency
base_pn	LM5023	Base Product Number
source	AC	Input Source Type
Ta	30.0	Ambient temperature

WEBENCH® Assembly

Component Testing

Some published data on components in datasheets such as Capacitor ESR and Inductor DC resistance is based on conservative values that will guarantee that the components always exceed the specification. For design purposes it is usually better to work with typical values. Since this data is not always available it is a good practice to measure the Capacitance and ESR values of C_{in} and C_{out} , and the inductance and DC resistance of L1 before assembly of the board. Any large discrepancies in values should be electrically simulated in WEBENCH to check for instabilities and thermally simulated in WebTHERM to make sure critical temperatures are not exceeded.

Soldering Component to Board

If board assembly is done in house it is best to tack down one terminal of a component on the board then solder the other terminal. For surface mount parts with large tabs, such as the DPAK, the tab on the back of the package should be pre-tinned with solder, then tacked into place by one of the pins. To solder the tab down to the board place the iron down on the board while resting against the tab, heating both surfaces simultaneously. Apply light pressure to the top of the plastic case until the solder flows around the part and the part is flush with the PCB. If the solder is not flowing around the board you may need a higher wattage iron (generally 25W to 30W is enough).

Initial Startup of Circuit

It is best to initially power up the board by setting the input supply voltage to the lowest operating input voltage 85.0V and set the input supply's current limit to zero. With the input supply off connect up the input supply to V_{in} and GND. Connect a digital volt meter and a load if needed to set the minimum load of the design from V_{out} and GND. Turn on the input supply and slowly turn up the current limit on the input supply. If the voltage starts to rise on the input supply continue increasing the input supply current limit while watching the output voltage. If the current increases on the input supply, but the voltage remains near zero, then there may be a short or a component misplaced on the board. Power down the board and visually inspect for solder bridges and recheck the diode and capacitor polarities. Once the power supply circuit is operational then more extensive testing may include full load testing, transient load and line tests to compare with simulation results.

Load Testing

The setup is the same as the initial startup, except that an additional digital voltmeter is connected between V_{in} and GND, a load is connected between V_{out} and GND and a current meter is connected in series between V_{out} and the load. The load must be able to handle at least rated output power + 50% (7.5 watts for this design). Ideally the load is supplied in the form of a variable load test unit. It can also be done in the form of suitably large power resistors. When using an oscilloscope to measure waveforms on the prototype board, the ground leads of the oscilloscope probes should be as short as possible and the area of the loop formed by the ground lead should be kept to a minimum. This will help reduce ground lead inductance and eliminate EMI noise that is not actually present in the circuit.

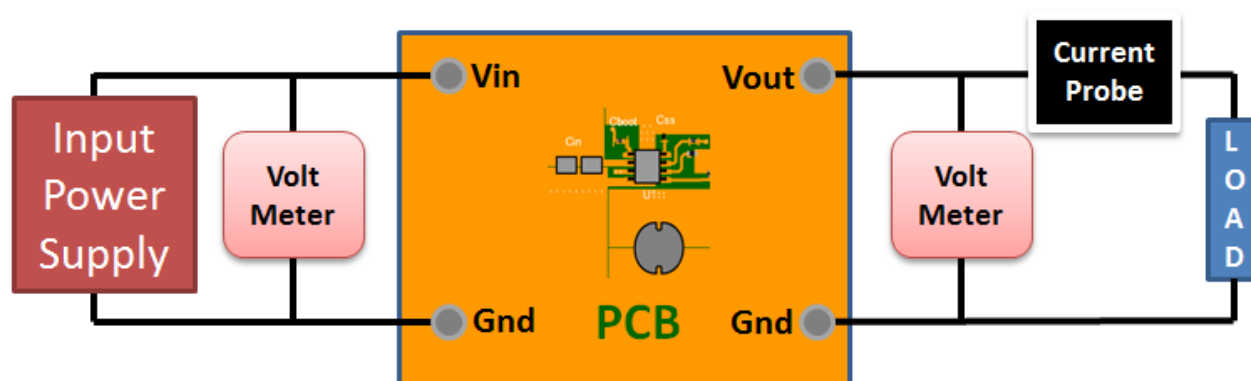

WEBENCH® Transformer Report

#	Name	Value
1.	Core Part Number	B65847A0000R087
2.	Core Manufacturer	TDK
3.	Coil Former Part Number	B65848D1010D001
4.	Coil Former Manufacturer	TDK

Transformer Electrical Diagram

Primary

Turns	68.0
AWG	29.0
Layers	4.0
Strands	2.0
Insulation Type	Heavy Insulated Magnet Wire

Auxiliary

Turns	7.0
AWG	28.0
Layers	1.0
Strands	4.0
Insulation Type	Heavy Insulated Magnet Wire

Secondary

Turns	9.0
AWG	28.0
Layers	1.0
Strands	2.0
Insulation Type	Triple Insulated

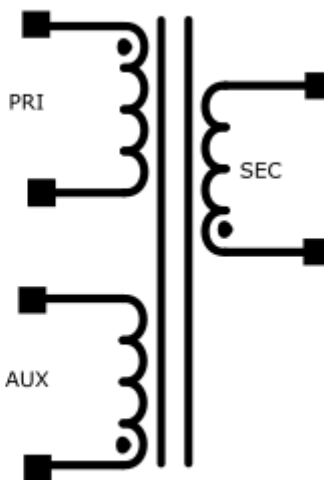

Transformer Construction Diagram

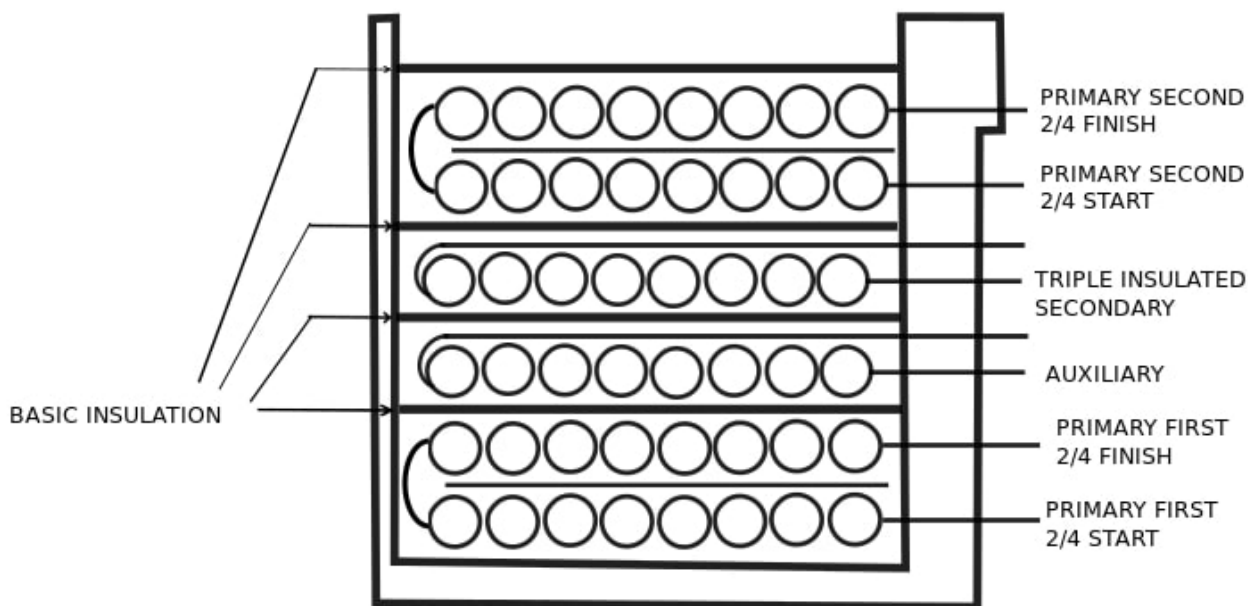

Winding Instruction

Winding	AWG	Turns	Winding Orientation
Primary First 2/4.0	29.0	34	Clockwise
Auxiliary	28.0	7.0	Counter Clockwise
Triple Insulated Secondary	28.0	9.0	Counter Clockwise
Primary Second 2/4.0	29.0	34	Clockwise

Transformer Parameters

#	Name	Value
1.	Lpri	8.17E-4H
2.	Inductance Factor(AI)	177.0nH
3.	Npri	68.0
4.	Nsec	9.0
5.	Naux	7.0
6.	Core Type	EP20
7.	Core Material	N87
8.	Bmax	0.23T
9.	Switching Frequency	45.00kHz
10.	DMax	0.45
11.	Ipk(Primary)	1.51A
12.	Irms(Primary)	0.58A
13.	Ipk(Secondary)	11.4A
14.	Irms(Secondary)	4.44A

Design Assistance

1. Master key : 235927DDE5FA19B1[v1]
2. **LM5023** Product Folder : <http://www.ti.com/product/LM5023> : contains the data sheet and other resources.

Important Notice and Disclaimer

TI provides technical and reliability data (including datasheets), design resources (including reference designs), application or other design advice, web tools, safety information, and other resources AS IS and with all faults, and disclaims all warranties. These resources are intended for skilled developers designing with TI products. You are solely responsible for (1) selecting the appropriate TI products for your application, (2) designing, validating and testing your application, and (3) ensuring your application meets applicable standards, and any other safety, security, or other requirements.

These resources are subject to change without notice. TI grants you permission to use these resources only for development of an application that uses the TI products described in the resource. Other reproduction and display of these resources is prohibited. No license is granted to any other TI intellectual property right or to any third party intellectual property right. TI disclaims responsibility for, and you will fully indemnify TI and its representatives against, any claims, damages, costs, losses, and liabilities arising out of your use of these resources.

Providing these resources does not expand or otherwise alter TI's applicable Terms of Sale or other applicable terms available either on ti.com or provided in conjunction with TI products.