

## WEBENCH® Design Report

 Design : 69 TPS55288RPMR  
 TPS55288RPMR 4V-36V to 12.00V @ 4A

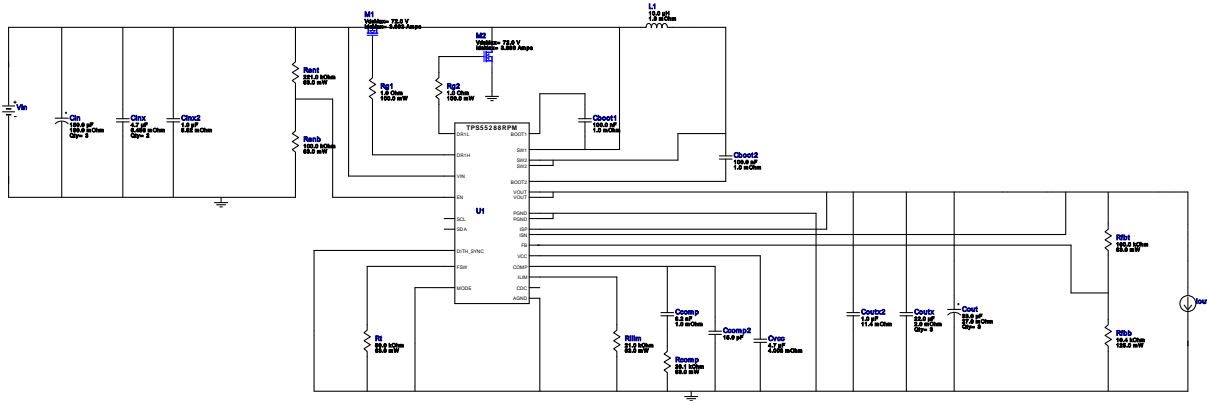







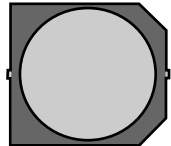

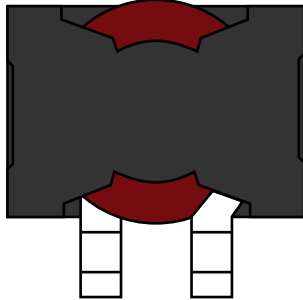

### Design Alerts

#### TPS55288 Design

With the design conditions, either the IC or the selected FET junction temperature is exceeded above the maximum rating. Hence, this design is created using an ideal FET. Please note that the resulting FET parameters are ideal, so the efficiency/loss opvals have been disabled. Also, the schematic/PCB export and Thermal simulations will not work with the ideal FET.

### Electrical BOM

Name	Manufacturer	Part Number	Properties	Qty	Price	Footprint
Cboot1	Taiyo Yuden	EMK107B7104KA-T Series= X7R	Cap= 100.0 nF ESR= 1.0 mOhm VDC= 16.0 V IRMS= 0.0 A	1	\$0.01	0603 5 mm <sup>2</sup>
Cboot2	Taiyo Yuden	EMK107B7104KA-T Series= X7R	Cap= 100.0 nF ESR= 1.0 mOhm VDC= 16.0 V IRMS= 0.0 A	1	\$0.01	0603 5 mm <sup>2</sup>
Ccomp	MuRata	GRM155R71C822KA01D Series= X7R	Cap= 8.2 nF ESR= 1.0 mOhm VDC= 16.0 V IRMS= 0.0 A	1	\$0.01	0402 3 mm <sup>2</sup>
Ccomp2	Kemet	C0402C150J4GACTU Series= C0G/NP0	Cap= 15.0 pF VDC= 16.0 V IRMS= 0.0 A	1	\$0.01	0402 3 mm <sup>2</sup>
Cin	Panasonic	EEV-FK1J151Q Series= FK	Cap= 150.0 uF ESR= 160.0 mOhm VDC= 63.0 V IRMS= 800.0 mA	3	\$0.91	 SM_RADIAL_H13 264 mm <sup>2</sup>
Cinx	Taiyo Yuden	MSASU32MSB7475MPNA01 Series= X7R	Cap= 4.7 uF ESR= 6.456 mOhm VDC= 50.0 V IRMS= 3.147 A	2	\$0.15	1210 15 mm <sup>2</sup>
Cinx2	TDK	C1608X5R1H105K080AB Series= X5R	Cap= 1.0 uF ESR= 5.52 mOhm VDC= 50.0 V IRMS= 0.0 A	1	\$0.04	0603 5 mm <sup>2</sup>

Name	Manufacturer	Part Number	Properties	Qty	Price	Footprint
Cout	Panasonic	20SVPG33M Series= SVPG	Cap= 33.0 uF ESR= 27.0 mOhm VDC= 20.0 V IRMS= 3.0 A	3	\$0.52	 CAPSMT_62_B45 53 mm <sup>2</sup>
Coutx	MuRata	GRM32ER61E226KE15L Series= X5R	Cap= 22.0 uF ESR= 2.0 mOhm VDC= 25.0 V IRMS= 3.67 A	3	\$0.23	 1210 15 mm <sup>2</sup>
Coutx2	TDK	C1005X5R1E105K050BC Series= X5R	Cap= 1.0 uF ESR= 11.4 mOhm VDC= 25.0 V IRMS= 0.0 A	1	\$0.02	 0402 3 mm <sup>2</sup>
Cvcc	TDK	C1608X5R1C475K080AC Series= X5R	Cap= 4.7 uF ESR= 4.008 mOhm VDC= 16.0 V IRMS= 0.0 A	1	\$0.06	 0603 5 mm <sup>2</sup>
L1	Coilcraft	SER2915H-103KL	L= 10.0 uH 1.9 mOhm	1	\$1.95	 SER2915H 652 mm <sup>2</sup>
M1	NA	IdealFET	VdsMax= 72.0 V IdsMax= 3.993 Amps	1	NA	KCS0003B 80 mm <sup>2</sup>
M2	NA	IdealFET	VdsMax= 72.0 V IdsMax= 3.993 Amps	1	NA	KCS0003B 80 mm <sup>2</sup>
Rcomp	Vishay-Dale	CRCW040226K1FKED Series= CRCW..e3	Res= 26.1 kOhm Power= 63.0 mW Tolerance= 1.0%	1	\$0.01	 0402 3 mm <sup>2</sup>
Renb	Vishay-Dale	CRCW0402100KFKED Series= CRCW..e3	Res= 100.0 kOhm Power= 63.0 mW Tolerance= 1.0%	1	\$0.01	 0402 3 mm <sup>2</sup>
Rent	Vishay-Dale	CRCW0402221KFKED Series= CRCW..e3	Res= 221.0 kOhm Power= 63.0 mW Tolerance= 1.0%	1	\$0.01	 0402 3 mm <sup>2</sup>
Rfbb	Yageo	RT0805BRD0710K4L Series= RT0805	Res= 10.4 kOhm Power= 125.0 mW Tolerance= 0.1%	1	\$0.05	 0805 7 mm <sup>2</sup>
Rfbt	Vishay-Dale	CRCW0402100KFKED Series= CRCW..e3	Res= 100.0 kOhm Power= 63.0 mW Tolerance= 1.0%	1	\$0.01	 0402 3 mm <sup>2</sup>
Rg1	Vishay-Dale	CRCW06031R00FKEA Series= CRCW..e3	Res= 1.0 Ohm Power= 100.0 mW Tolerance= 1.0%	1	\$0.01	 0603 5 mm <sup>2</sup>
Rg2	Vishay-Dale	CRCW06031R00FKEA Series= CRCW..e3	Res= 1.0 Ohm Power= 100.0 mW Tolerance= 1.0%	1	\$0.01	 0603 5 mm <sup>2</sup>
Rilim	Vishay-Dale	CRCW040221K0FKED Series= CRCW..e3	Res= 21.0 kOhm Power= 63.0 mW Tolerance= 1.0%	1	\$0.01	 0402 3 mm <sup>2</sup>
Rt	Vishay-Dale	CRCW040250K0FKED Series= 0402	Res= 50.0 kOhm Power= 63.0 mW Tolerance= 1.0%	1	\$0.01	 0402 3 mm <sup>2</sup>
U1	Texas Instruments	TPS55288RPMR	Switcher	1	\$2.54	RPM0026A 22 mm <sup>2</sup>

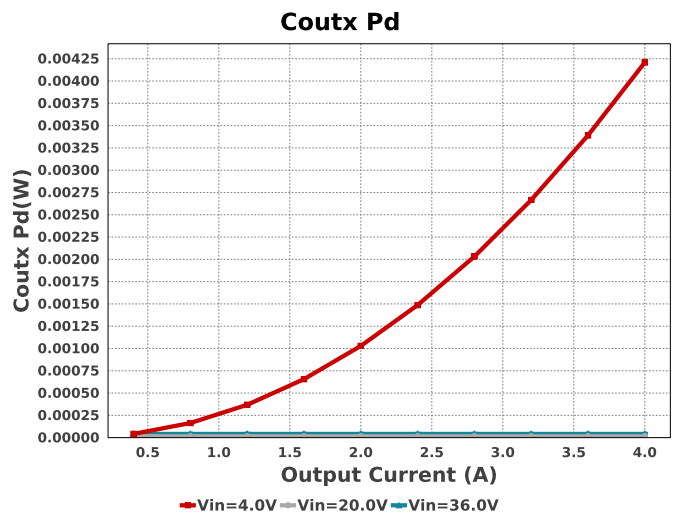
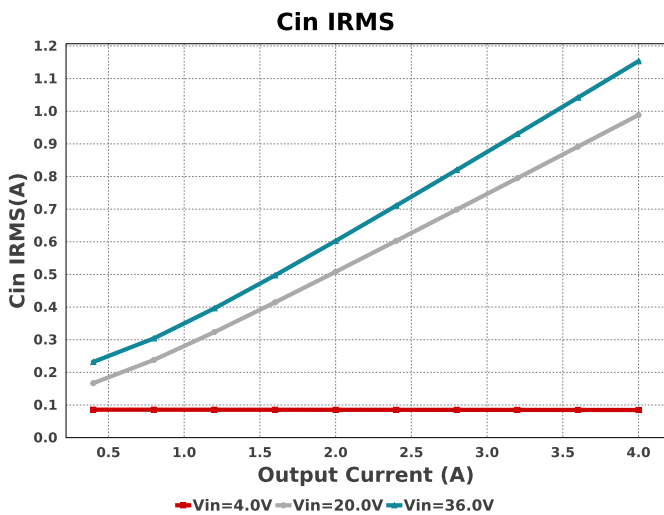
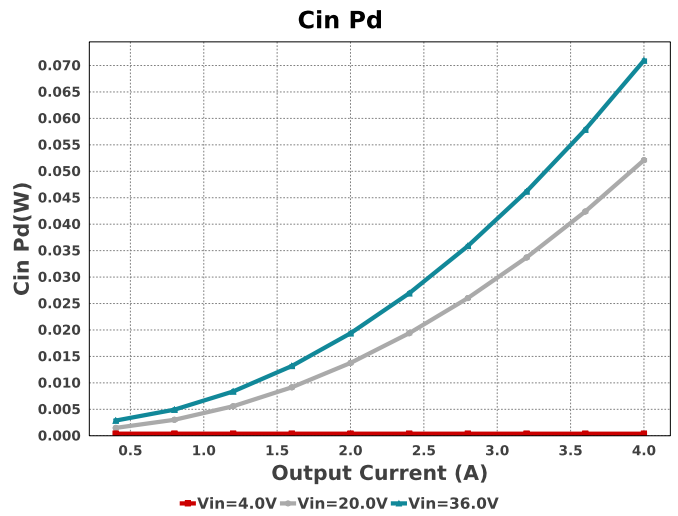
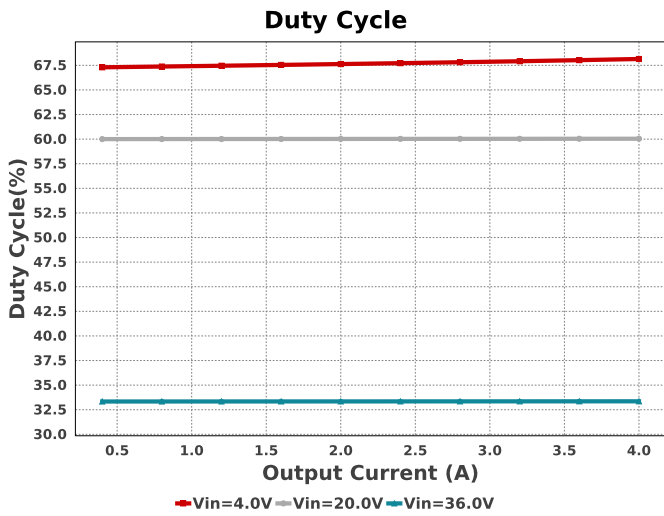
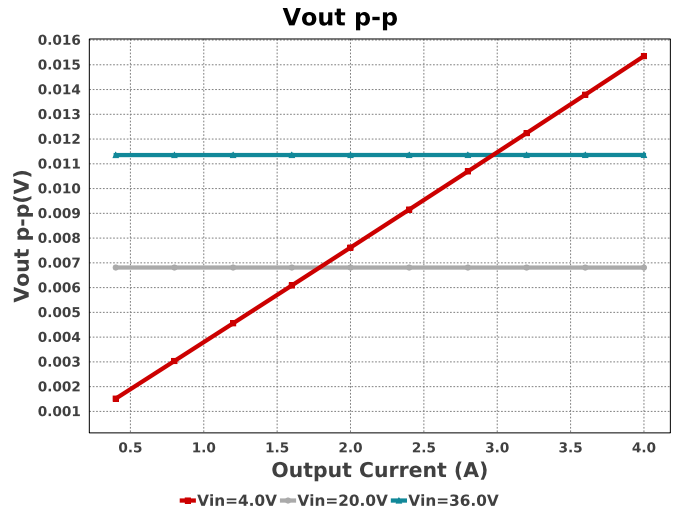
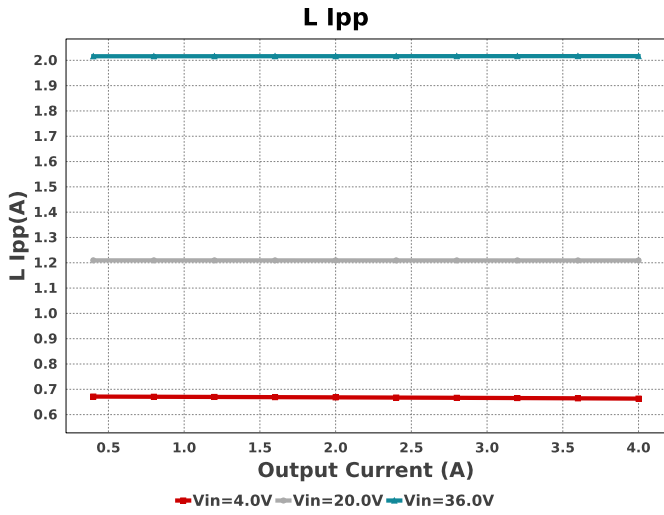

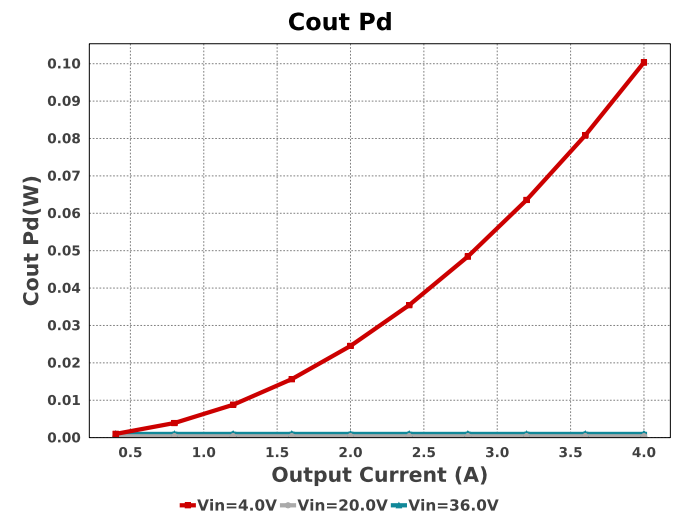
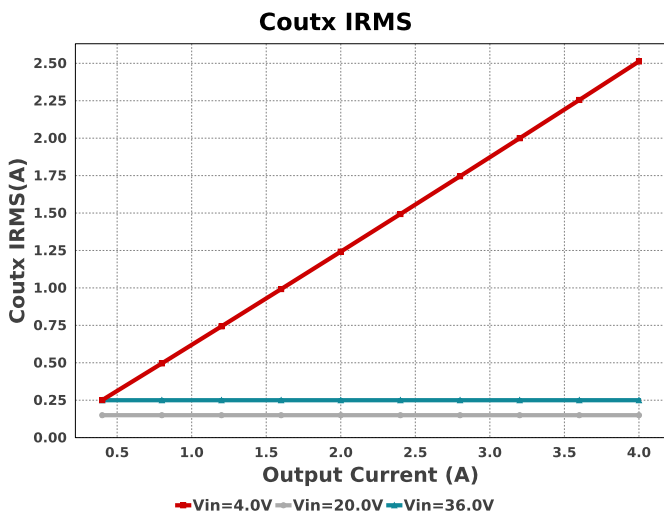
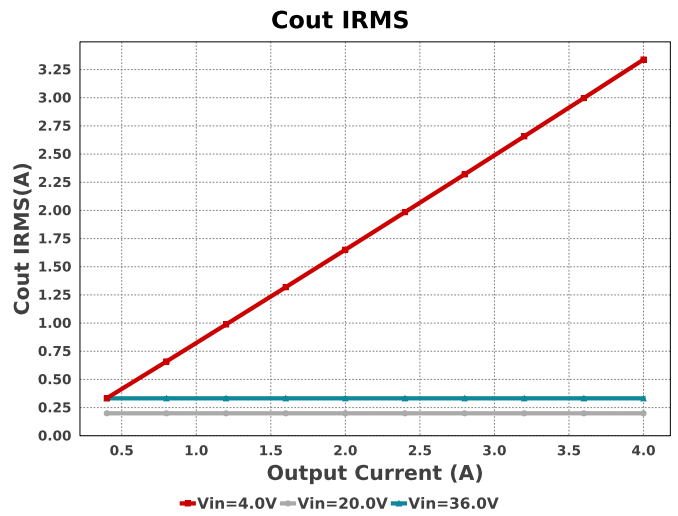
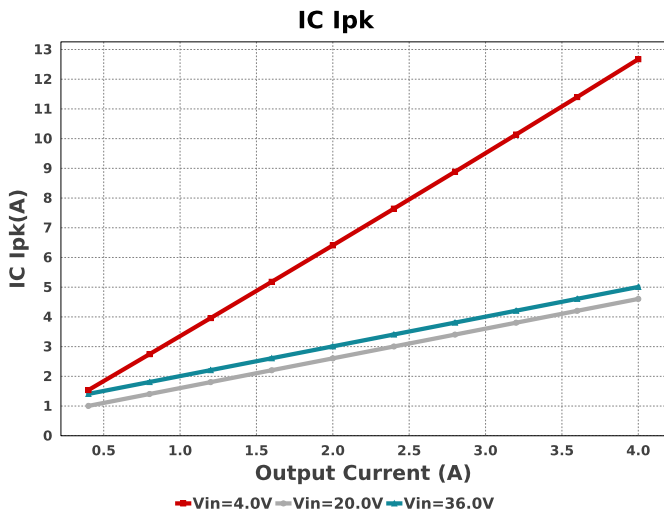
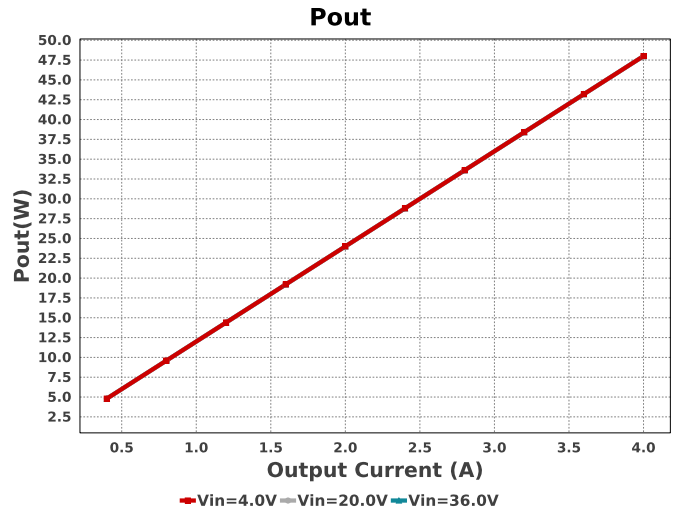
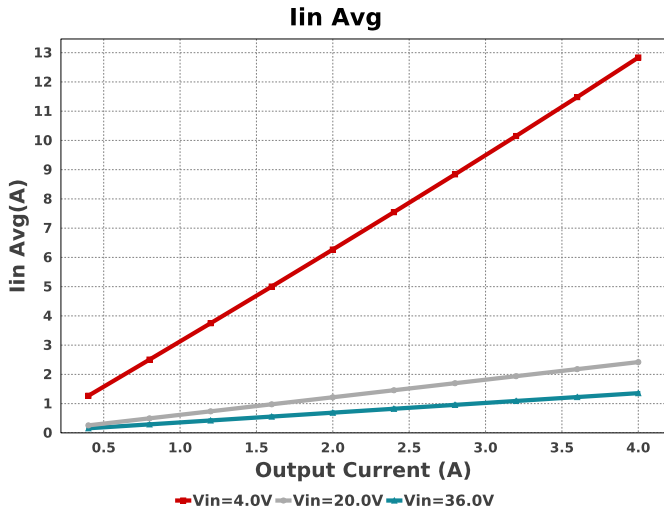

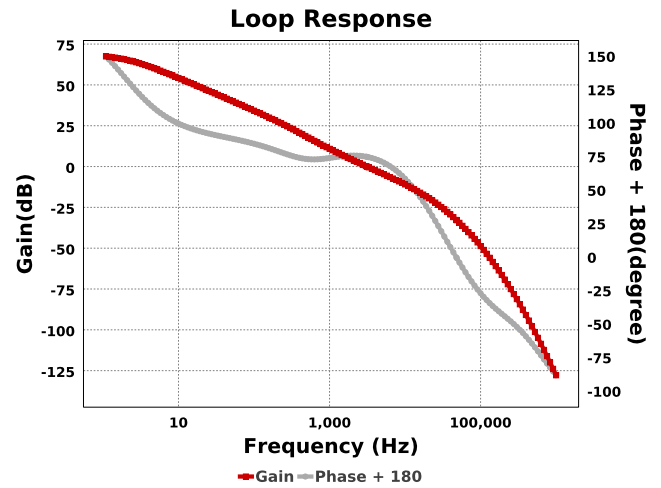
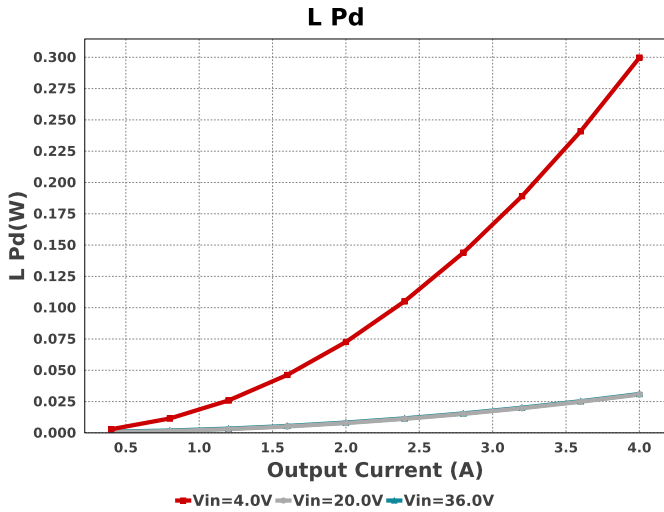

### Operating Values

#	Name	Value	Category	Description
1.	Cin IRMS	84.688 mA	Capacitor	Input capacitor RMS ripple current
2.	Cin Pd	382.51 μW	Capacitor	Input capacitor power dissipation
3.	Cout IRMS	3.339 A	Capacitor	Output capacitor RMS ripple current
4.	Cout Pd	100.34 mW	Capacitor	Output capacitor power dissipation
5.	Coutx IRMS	2.513 A	Capacitor	Output capacitor_x RMS ripple current
6.	Coutx Pd	4.209 mW	Capacitor	Output capacitor_x power loss
7.	IC Ipk	12.674 A	IC	Peak switch current in IC
8.	IC Tolerance	12.0 mV	IC	IC Feedback Tolerance
9.	ICThetaJA Effective	38.0 degC/W	IC	Effective IC Junction-to-Ambient Thermal Resistance
10.	Iin Avg	12.835 A	IC	Average input current
11.	L Ipp	663.18 mA	Inductor	Peak-to-peak inductor ripple current
12.	L Pd	299.67 mW	Inductor	Inductor power dissipation
13.	Cin Pd	382.51 μW	Power	Input capacitor power dissipation
14.	Cout Pd	100.34 mW	Power	Output capacitor power dissipation
15.	Coutx Pd	4.209 mW	Power	Output capacitor_x power loss
16.	L Pd	299.67 mW	Power	Inductor power dissipation
17.	BOM Count	31	System	Total Design BOM count
18.	Cross Freq	989.889 Hz	System	Bode plot crossover frequency
19.	Duty Cycle	68.146 %	System	Duty cycle
20.	FootPrint	1.919 k mm <sup>2</sup>	System	Total Foot Print Area of BOM components
21.	Frequency	396.825 kHz	System	Switching frequency
22.	Gain Marg	-13.907 dB	System	Bode Plot Gain Margin
23.	Iout	4.0 A	System	Iout operating point
24.	Low Freq Gain	51.87 dB	System	Gain at 1Hz
25.	Mode	CCM	System	Conduction Mode
26.	Phase Marg	81.198 deg	System	Bode Plot Phase Margin
27.	Pout	48.0 W	System	Total output power
28.	Total BOM	NA	System	Total BOM Cost
29.	Vin	4.0 V	System	Vin operating point
30.	Vout	12.0 V	System	Operational Output Voltage
31.	Vout Actual	2.994 V	System	Vout Actual calculated based on selected voltage divider resistors
32.	Vout Tolerance	5.295 %	System	Vout Tolerance based on IC Tolerance (no load) and voltage divider resistors if applicable
33.	Vout p-p	15.35 mV	System	Peak-to-peak output ripple voltage
34.	Vref	230.0 h;	System	Register VREF

## Design Inputs

Name	Value	Description
Iout	4.0	Maximum Output Current
VinMax	36.0	Maximum input voltage
VinMin	4.0	Minimum input voltage
Vout	12.0	Output Voltage
base_pn	TPS55288	Base Product Number
source	DC	Input Source Type
Ta	30.0	Ambient temperature
UserFsw	397.0 k	Customer Selected Frequency

## WEBENCH® Assembly

### Component Testing

Some published data on components in datasheets such as Capacitor ESR and Inductor DC resistance is based on conservative values that will guarantee that the components always exceed the specification. For design purposes it is usually better to work with typical values. Since this data is not always available it is a good practice to measure the Capacitance and ESR values of  $C_{in}$  and  $C_{out}$ , and the inductance and DC resistance of L1 before assembly of the board. Any large discrepancies in values should be electrically simulated in WEBENCH to check for instabilities and thermally simulated in WebTHERM to make sure critical temperatures are not exceeded.

### Soldering Component to Board

If board assembly is done in house it is best to tack down one terminal of a component on the board then solder the other terminal. For surface mount parts with large tabs, such as the DPAK, the tab on the back of the package should be pre-tinned with solder, then tacked into place by one of the pins. To solder the tab down to the board place the iron down on the board while resting against the tab, heating both surfaces simultaneously. Apply light pressure to the top of the plastic case until the solder flows around the part and the part is flush with the PCB. If the solder is not flowing around the board you may need a higher wattage iron (generally 25W to 30W is enough).

### Initial Startup of Circuit

It is best to initially power up the board by setting the input supply voltage to the lowest operating input voltage 4.0V and set the input supply's current limit to zero. With the input supply off connect up the input supply to  $V_{in}$  and GND. Connect a digital volt meter and a load if needed to set the minimum load of the design from  $V_{out}$  and GND. Turn on the input supply and slowly turn up the current limit on the input supply. If the voltage starts to rise on the input supply continue increasing the input supply current limit while watching the output voltage. If the current increases on the input supply, but the voltage remains near zero, then there may be a short or a component misplaced on the board. Power down the board and visually inspect for solder bridges and recheck the diode and capacitor polarities. Once the power supply circuit is operational then more extensive testing may include full load testing, transient load and line tests to compare with simulation results.

### Load Testing

The setup is the same as the initial startup, except that an additional digital voltmeter is connected between  $V_{in}$  and GND, a load is connected between  $V_{out}$  and GND and a current meter is connected in series between  $V_{out}$  and the load. The load must be able to handle at least rated output power + 50% ( 7.5 watts for this design). Ideally the load is supplied in the form of a variable load test unit. It can also be done in the form of suitably large power resistors. When using an oscilloscope to measure waveforms on the prototype board, the ground leads of the oscilloscope probes should be as short as possible and the area of the loop formed by the ground lead should be kept to a minimum. This will help reduce ground lead inductance and eliminate EMI noise that is not actually present in the circuit.

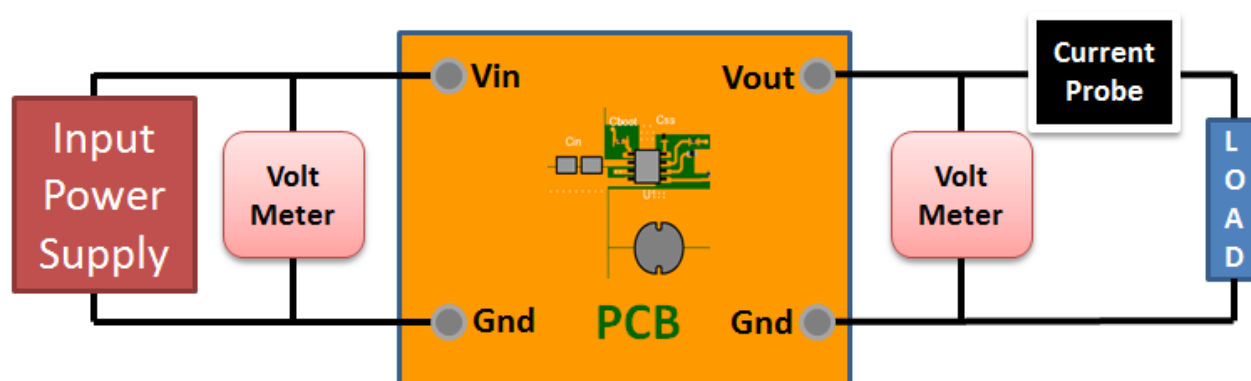

# WEBENCH® Electrical Simulation Report

Design Id = 69

sim\_id = 1

Simulation Type = Startup

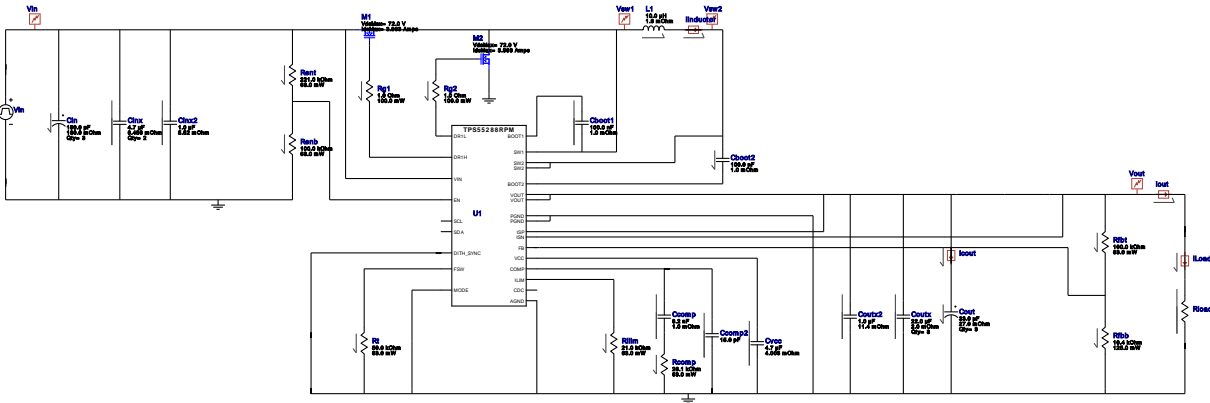

## Simulation Parameters

#	Name	Parameter Name	Description	Values
1.	Rload	R	Load Resistance	3.0 Ohm

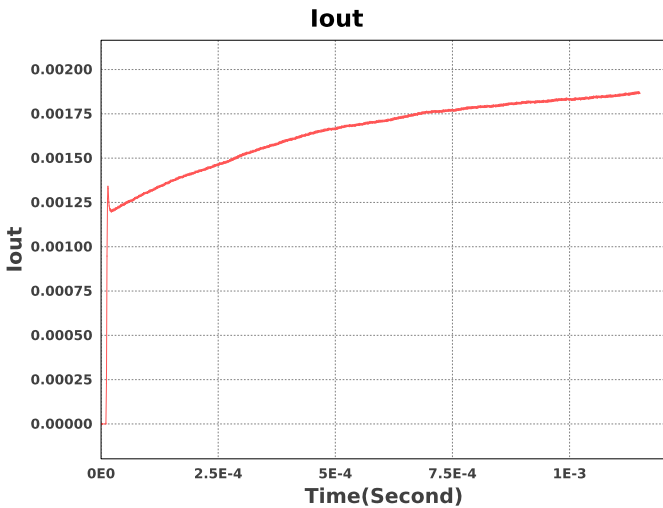
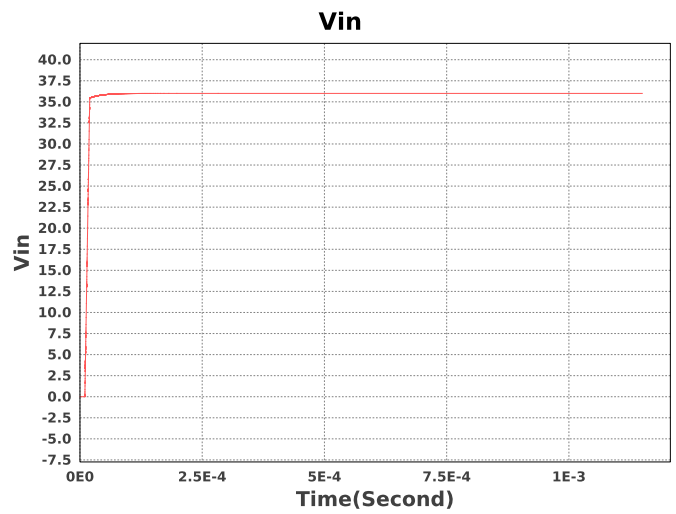
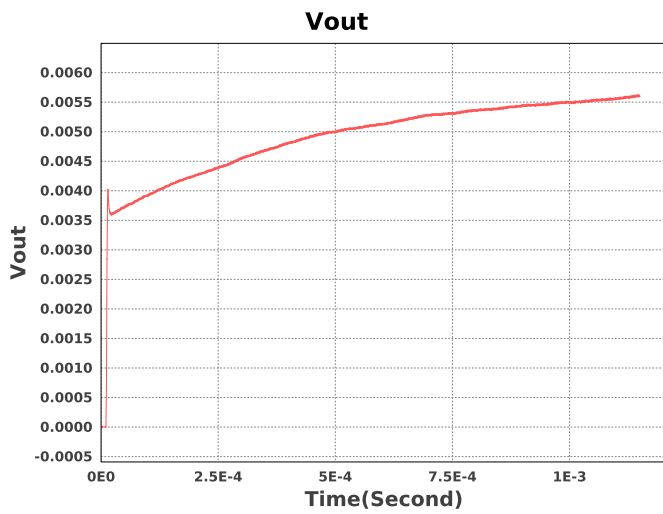

Design Id = 69

sim\_id = 2

Simulation Type = Load Transient

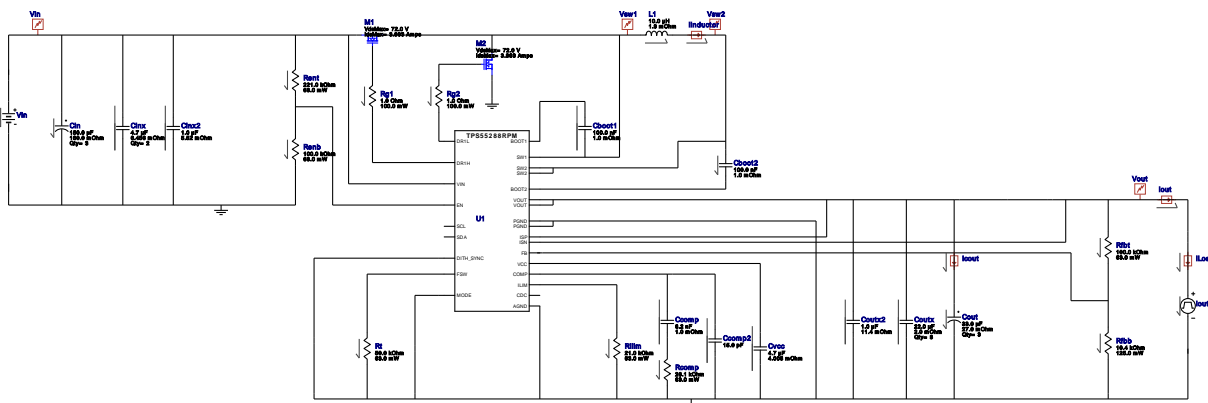

### Simulation Parameters

#	Name	Parameter Name	Description	Values
1.	Iload	I	Load Current	Iload1 A
2.	Iout	signal_type	Signal Type	PULSE
		I1	Initial Load Current	4.0 A
		I2	Minimum Load Current	0.4 A
		Td	Initial Time Delay	185u s
		Tf	Fall Time	10u s
		Tr	Rise Time	10u s
		Pw	Pulse Width	5.5E-4 s

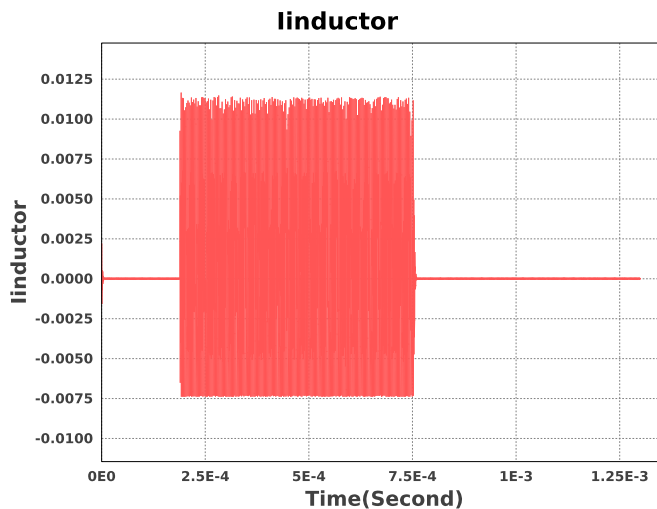
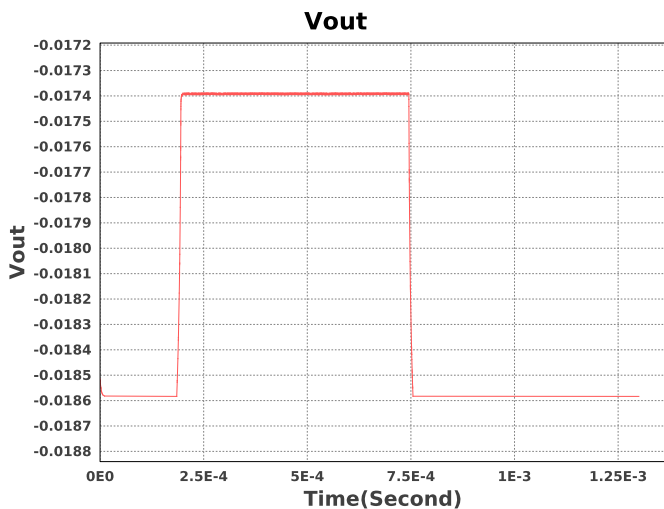

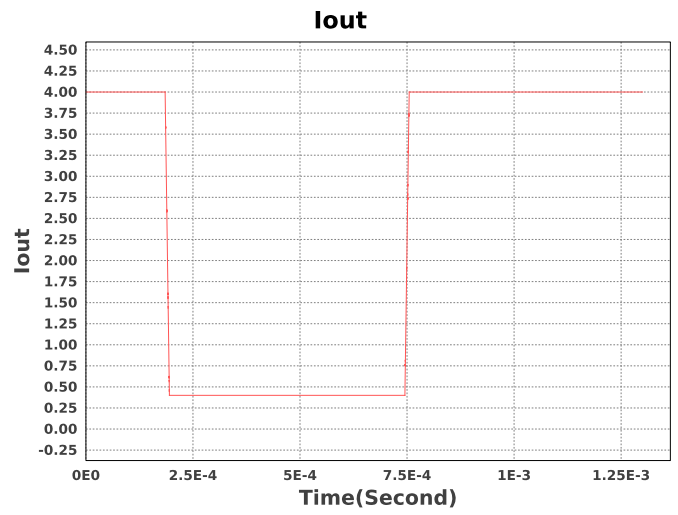
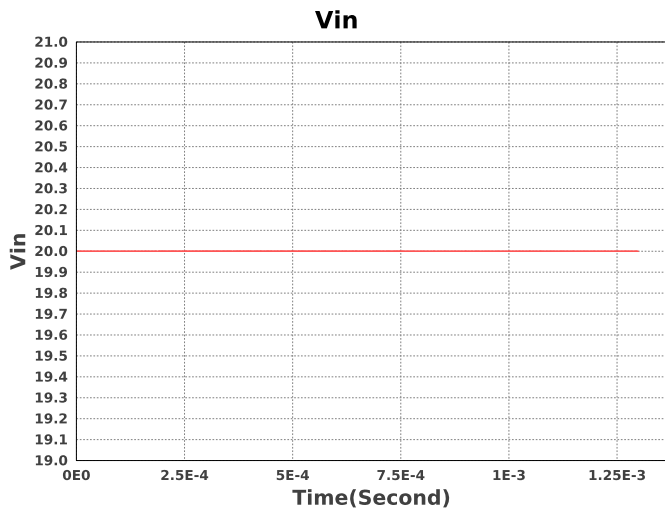

Design Id = 69

sim\_id = 3

Simulation Type = Input Transient

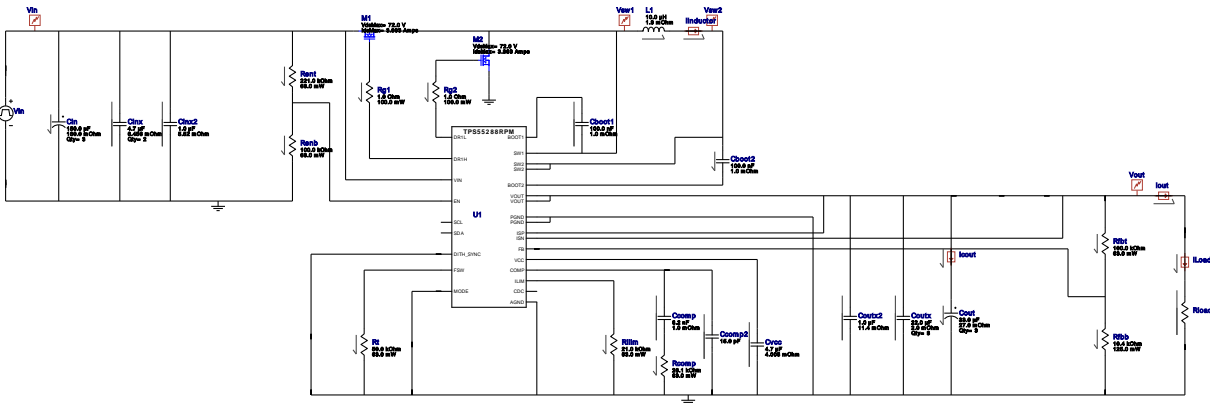

### Simulation Parameters

#	Name	Parameter Name	Description	Values
1.	Rload	R	Load Resistance	3.0 Ohm

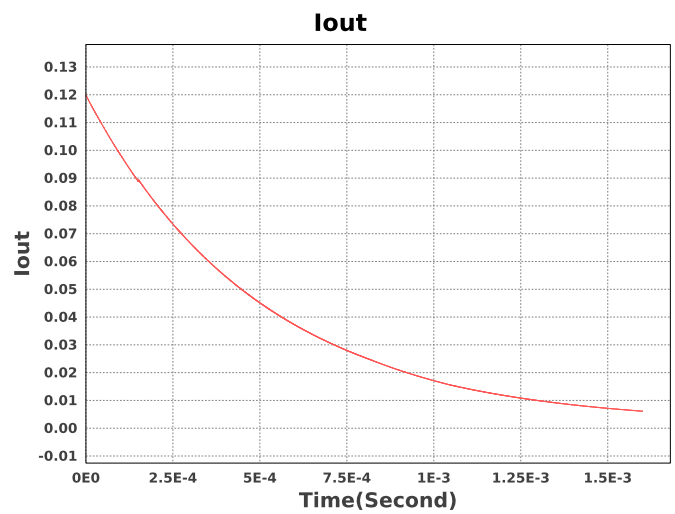
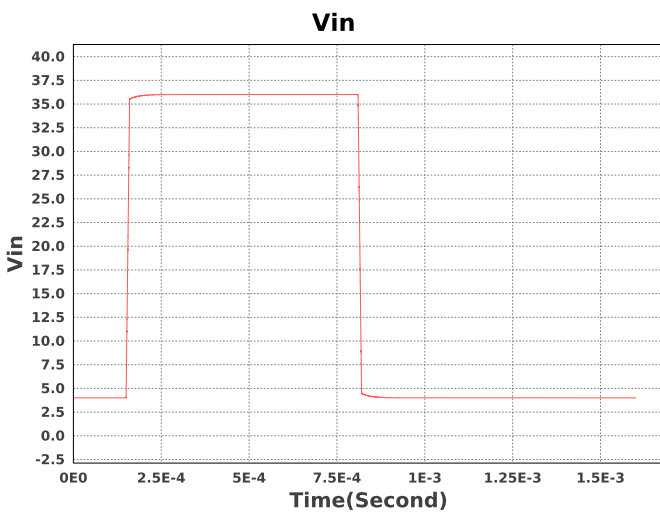
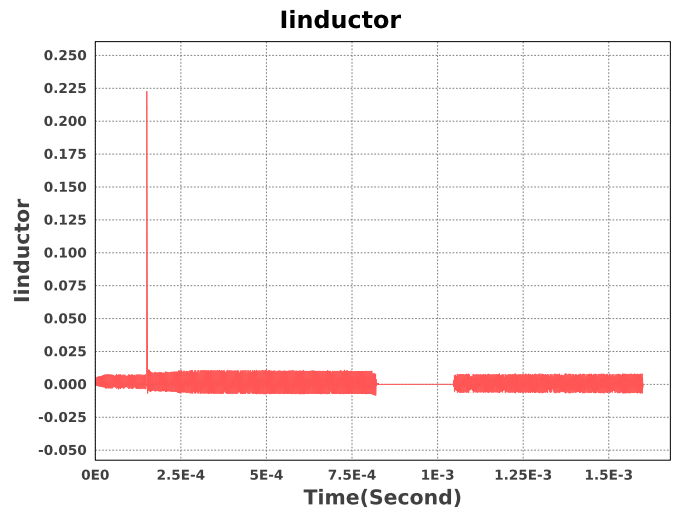
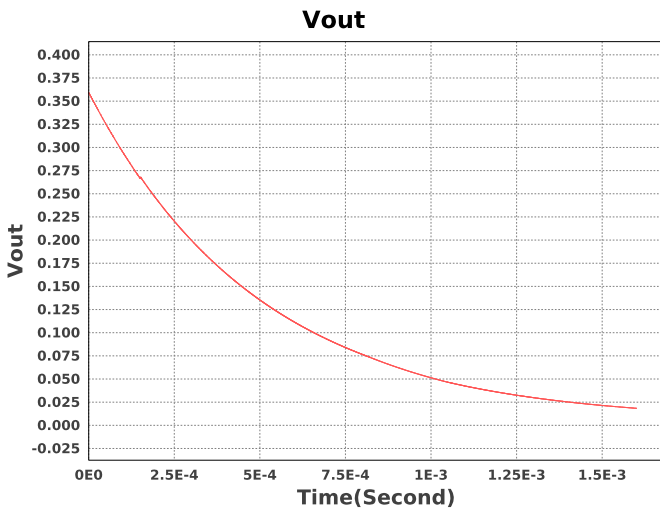

Design Id = 69

sim\_id = 4

Simulation Type = Steady State

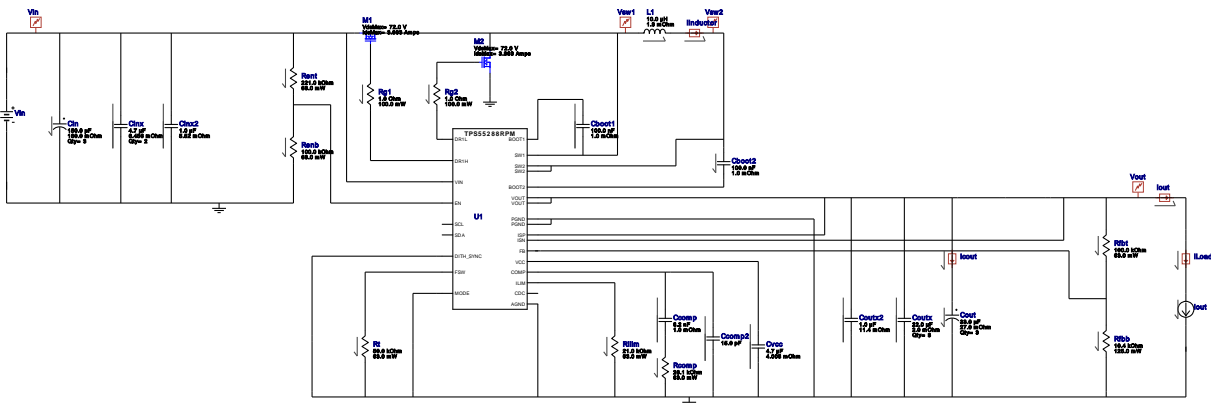

### Simulation Parameters

#	Name	Parameter Name	Description	Values
1.	Iout	I	Load Current	4.0 A

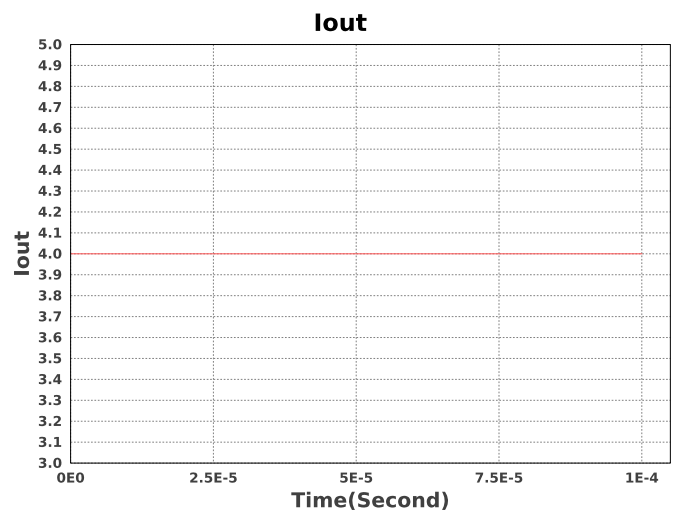
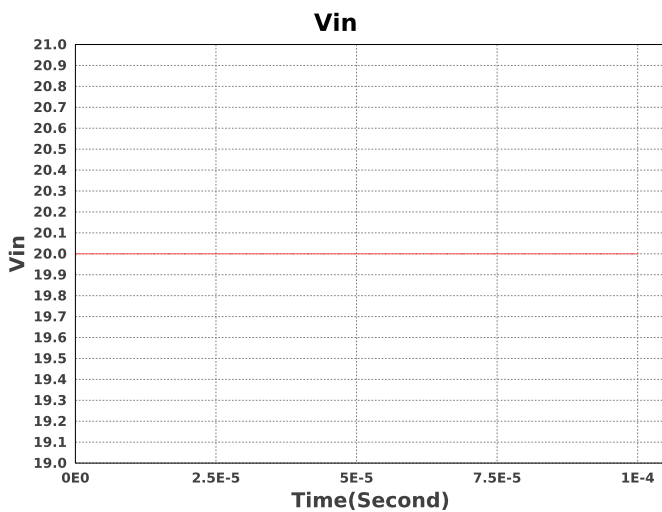
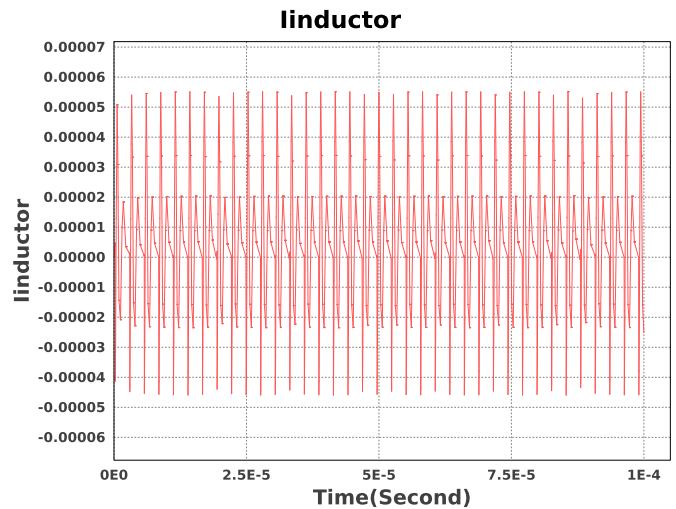
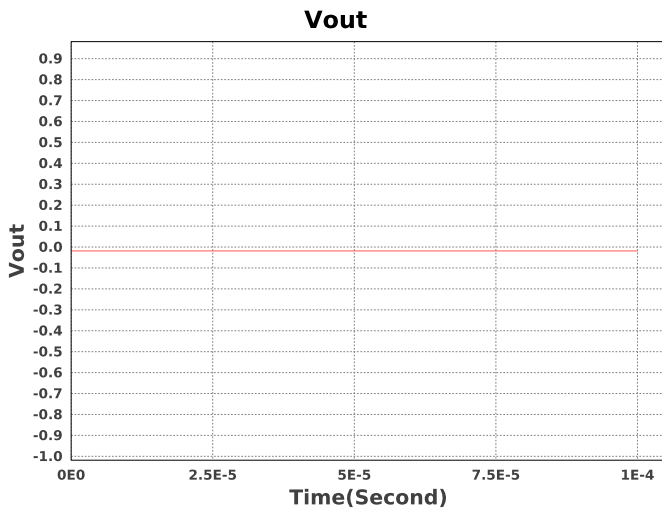

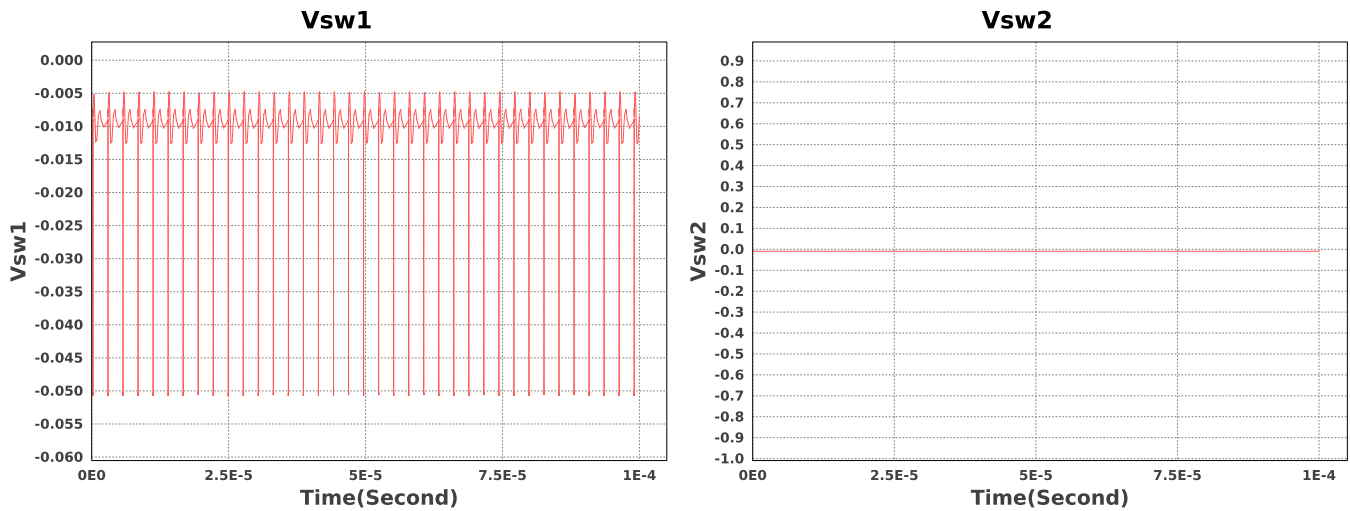

## Design Assistance

1. Master key : 8F2346D659A9BBD0[v1]
2. **TPS55288** Product Folder : <http://www.ti.com/product/TPS55288> : contains the data sheet and other resources.

### Important Notice and Disclaimer

TI provides technical and reliability data (including datasheets), design resources (including reference designs), application or other design advice, web tools, safety information, and other resources AS IS and with all faults, and disclaims all warranties. These resources are intended for skilled developers designing with TI products. You are solely responsible for (1) selecting the appropriate TI products for your application, (2) designing, validating and testing your application, and (3) ensuring your application meets applicable standards, and any other safety, security, or other requirements.

These resources are subject to change without notice. TI grants you permission to use these resources only for development of an application that uses the TI products described in the resource. Other reproduction and display of these resources is prohibited. No license is granted to any other TI intellectual property right or to any third party intellectual property right. TI disclaims responsibility for, and you will fully indemnify TI and its representatives against, any claims, damages, costs, losses, and liabilities arising out of your use of these resources.

Providing these resources does not expand or otherwise alter TI's applicable Terms of Sale or other applicable terms available either on ti.com or provided in conjunction with TI products.