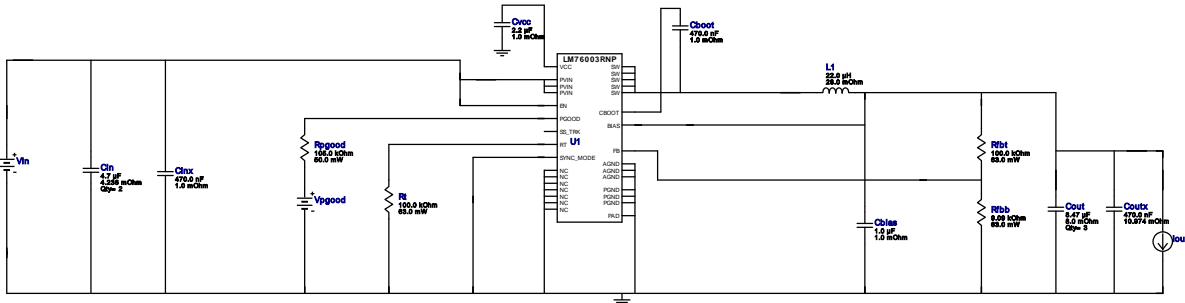
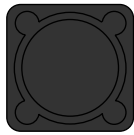

WEBENCH[®] Design Report

 Design : 74 LM76003RNPR
 LM76003RNPR 40V-48V to 12.00V @ 3.5A

1. The input capacitor included in the BOM only contains a small filter capacitor that should be placed near the IC. Depending on where the power supply is laid out in the system additional bulk capacitance may need to be added to filter the line ripple.

Electrical BOM

Name	Manufacturer	Part Number	Properties	Qty	Price	Footprint
Cbias	Taiyo Yuden	TMK212B7105KG-T Series= X7R	Cap= 1.0 uF ESR= 1.0 mOhm VDC= 25.0 V IRMS= 0.0 A	1	\$0.02	0805 7 mm ²
Cboot	MuRata	GRM155R60J474KE19D Series= X5R	Cap= 470.0 nF ESR= 1.0 mOhm VDC= 6.3 V IRMS= 0.0 A	1	\$0.02	0402 3 mm ²
Cin	TDK	CGA6M3X7S2A475K200AB Series= X7S	Cap= 4.7 uF ESR= 4.236 mOhm VDC= 100.0 V IRMS= 3.57337 A	2	\$0.47	1210_220 15 mm ²
Cinx	MuRata	GRM21BR72A474KA73L Series= X7R	Cap= 470.0 nF ESR= 1.0 mOhm VDC= 100.0 V IRMS= 0.0 A	1	\$0.16	0805 7 mm ²
Cout	Murata	GRM32ER71E226ME15L Series= X5R	Cap= 8.47 uF ESR= 8.0 mOhm VDC= 50.0 V IRMS= 4.6 A	3	\$0.50	CKG57N 4 mm ²
Coutx	TDK	C1608X7R1H474K080AC Series= X7R	Cap= 470.0 nF ESR= 10.974 mOhm VDC= 50.0 V IRMS= 1.57483 A	1	\$0.05	0603 5 mm ²
Cvcc	Taiyo Yuden	EMK212BJ225KG-T Series= X5R	Cap= 2.2 uF ESR= 1.0 mOhm VDC= 16.0 V IRMS= 0.0 A	1	\$0.02	0805 7 mm ²
L1	Würth Elektronik	7447709220	L= 22.0 uH 28.0 mOhm	1	\$1.39	 WE-PD_1210 196 mm ²
Rfbb	Vishay-Dale	CRCW04029K09FKED Series= CRCW..e3	Res= 9.09 kOhm Power= 63.0 mW Tolerance= 1.0%	1	\$0.01	0402 3 mm ²

Name	Manufacturer	Part Number	Properties	Qty	Price	Footprint
Rfbt	Vishay-Dale	CRCW0402100KFKED Series= CRCW..e3	Res= 100.0 kOhm Power= 63.0 mW Tolerance= 1.0%	1	\$0.01	0402 3 mm ²
Rpgood	Yageo	RC0201FR-07105KL Series= ?	Res= 105.0 kOhm Power= 50.0 mW Tolerance= 1.0%	1	\$0.01	0201 2 mm ²
Rt	Vishay-Dale	CRCW0402100KFKED Series= CRCW..e3	Res= 100.0 kOhm Power= 63.0 mW Tolerance= 1.0%	1	\$0.01	0402 3 mm ²
U1	Texas Instruments	LM76003RNPR	Switcher	1	\$1.92	RNP0030B 48 mm ²

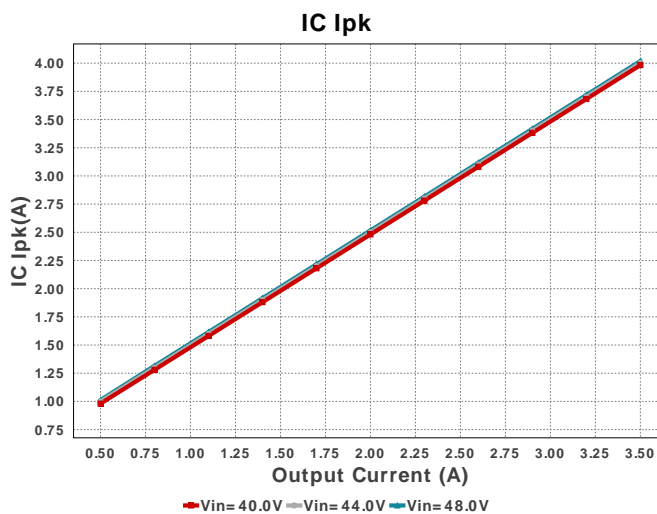
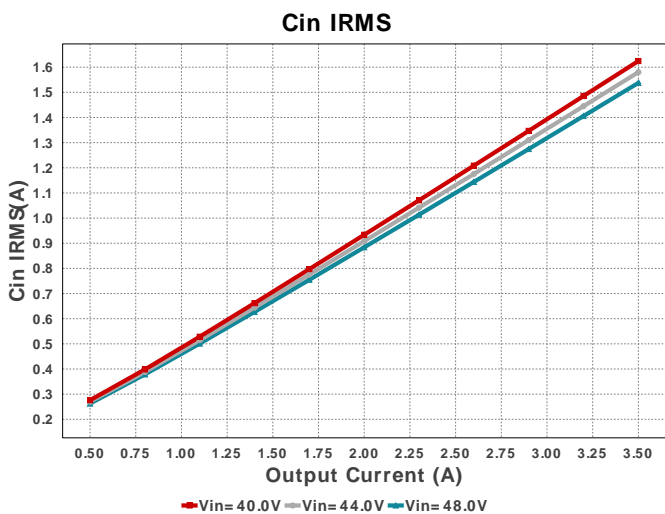
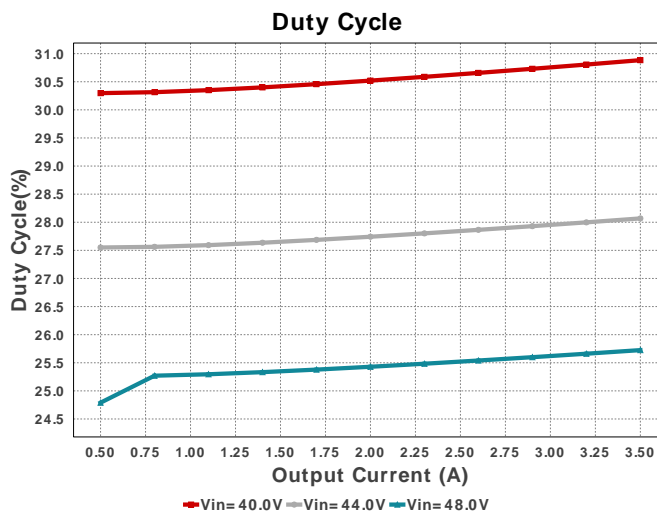
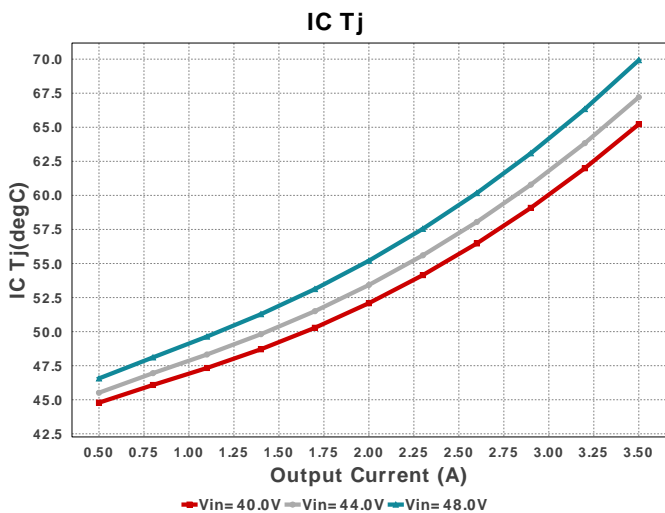

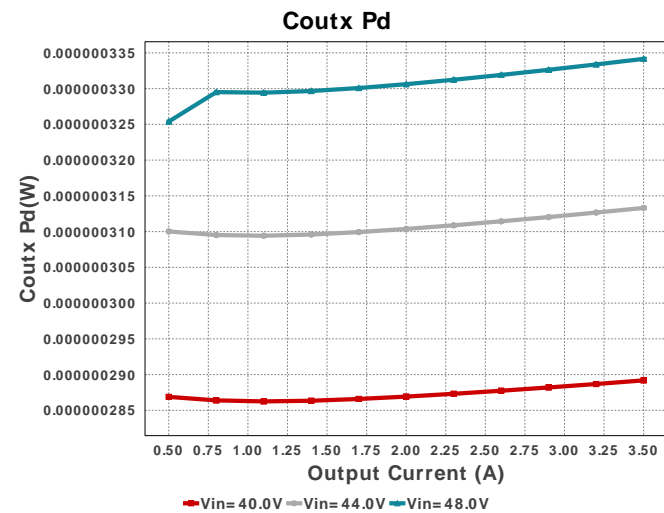
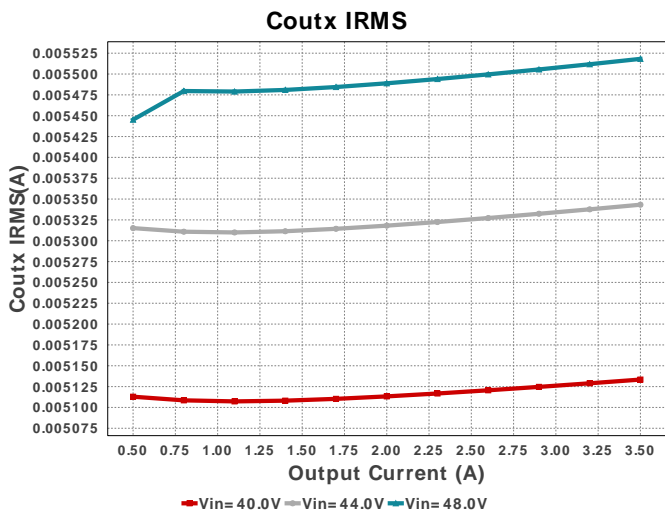
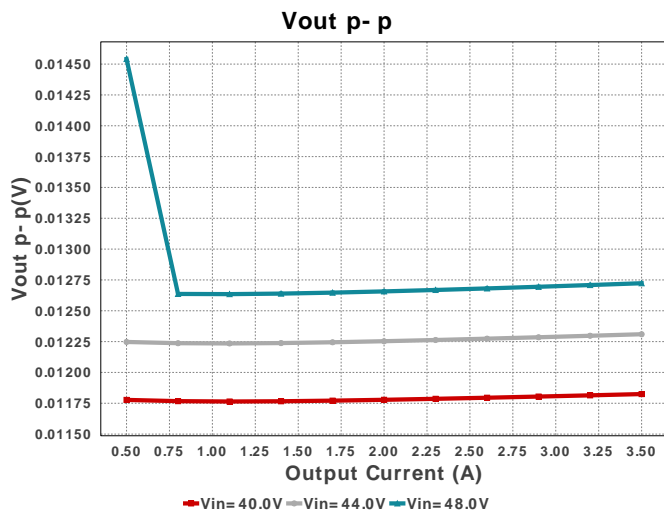
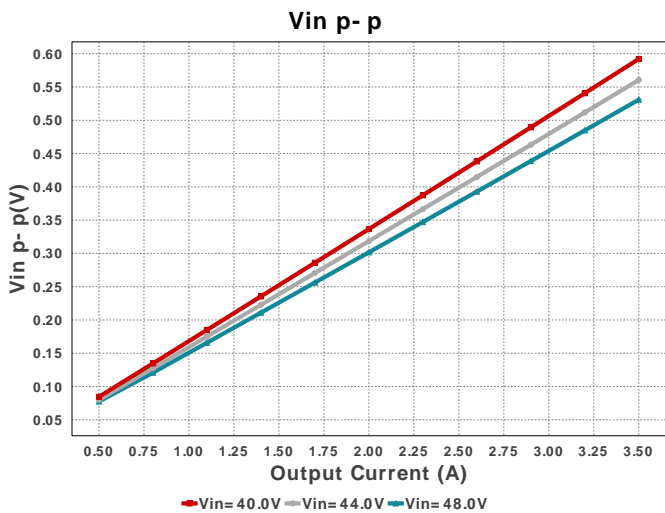
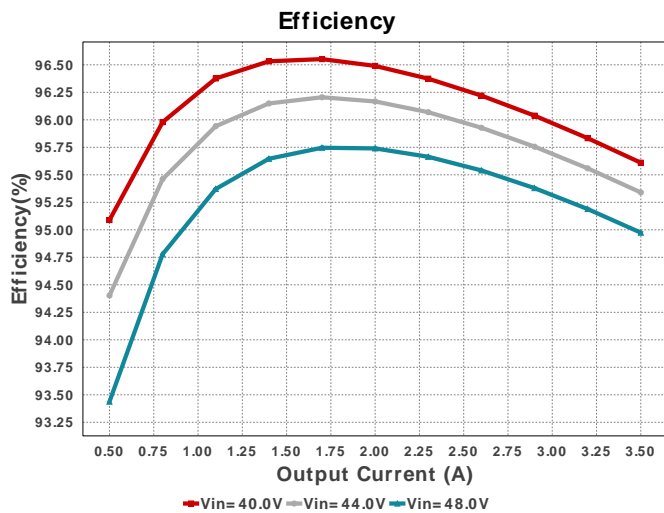
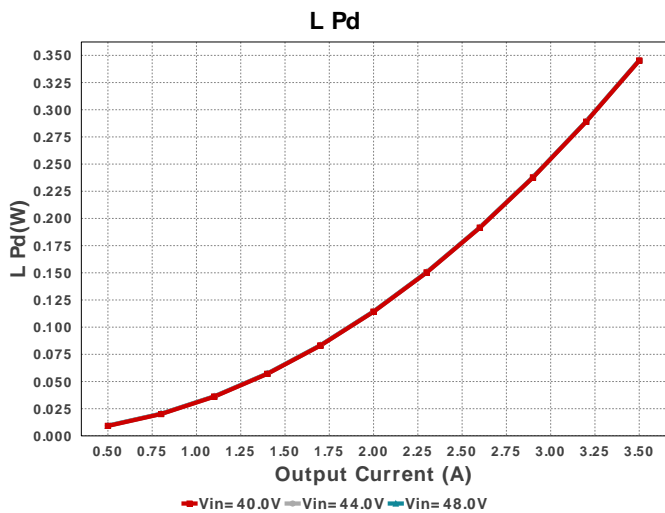

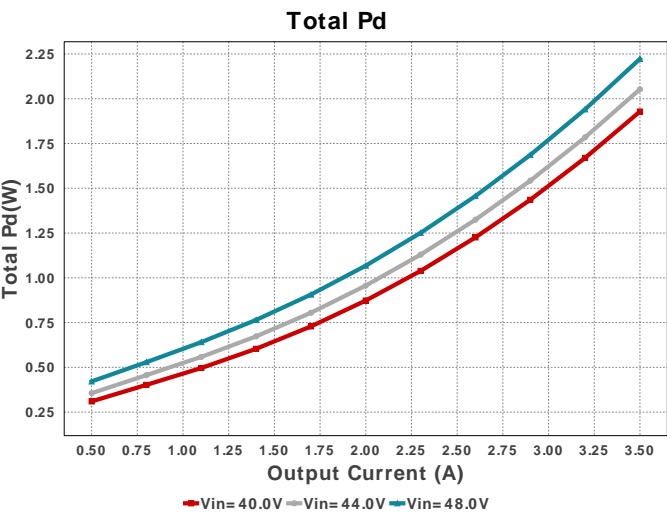
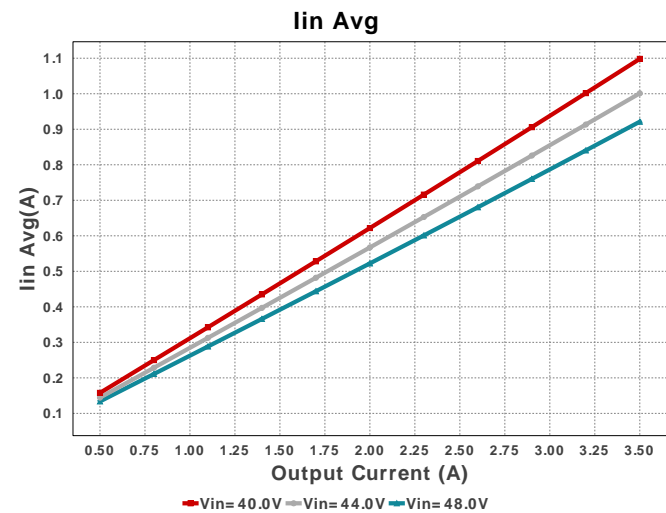
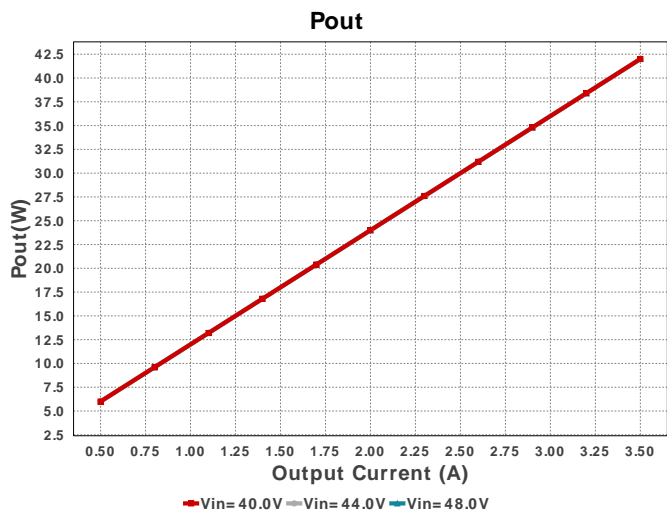
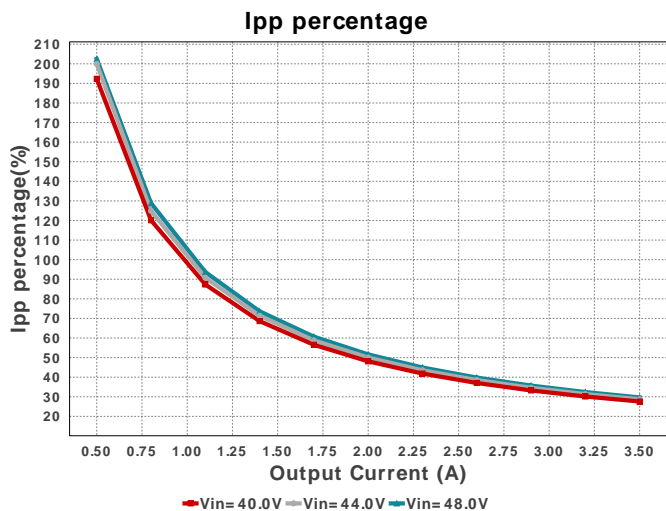
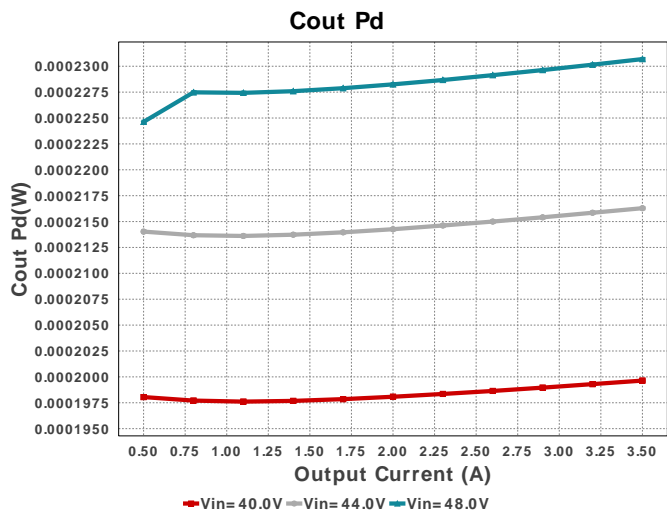
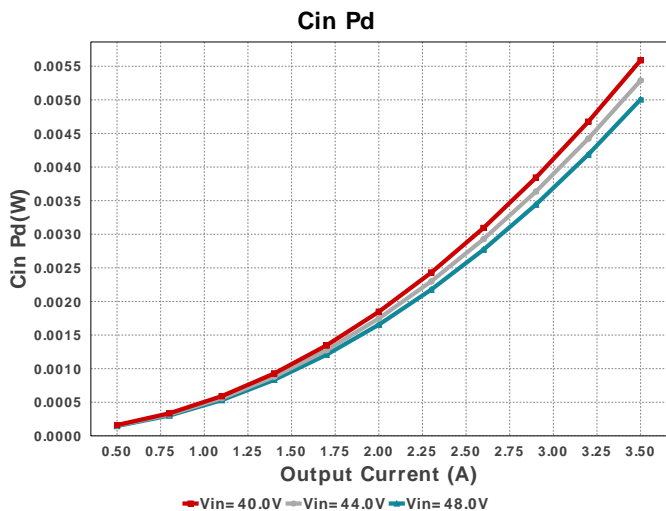

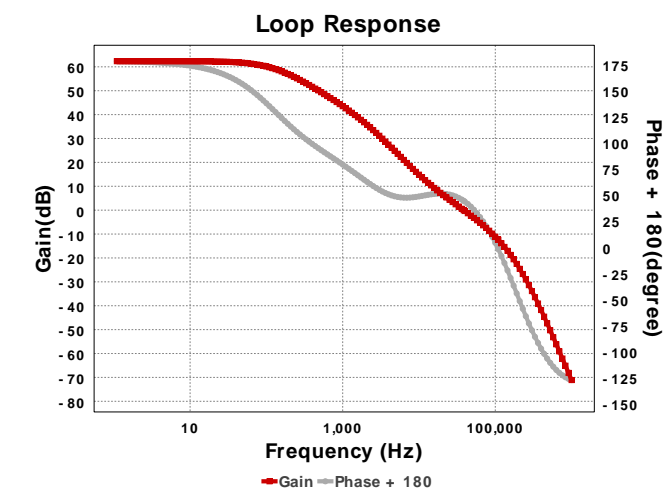
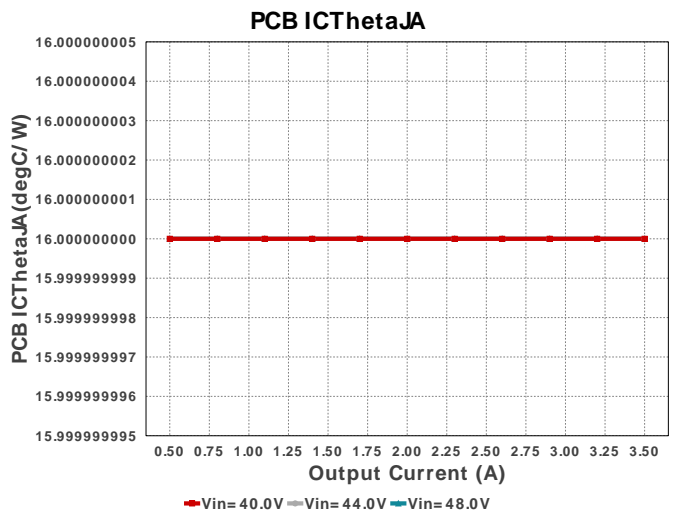
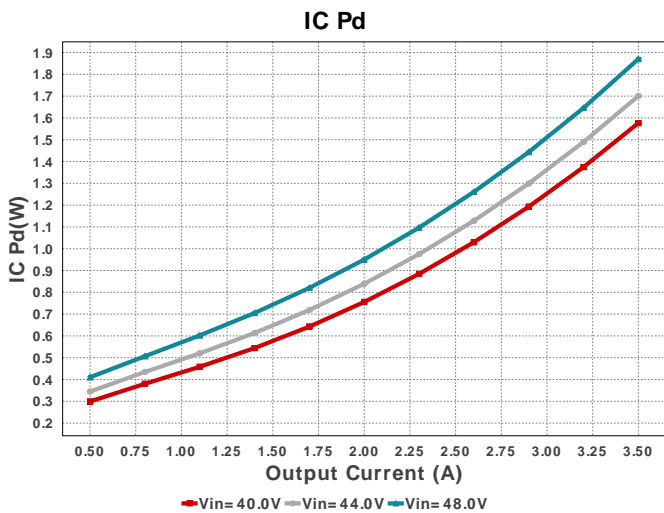
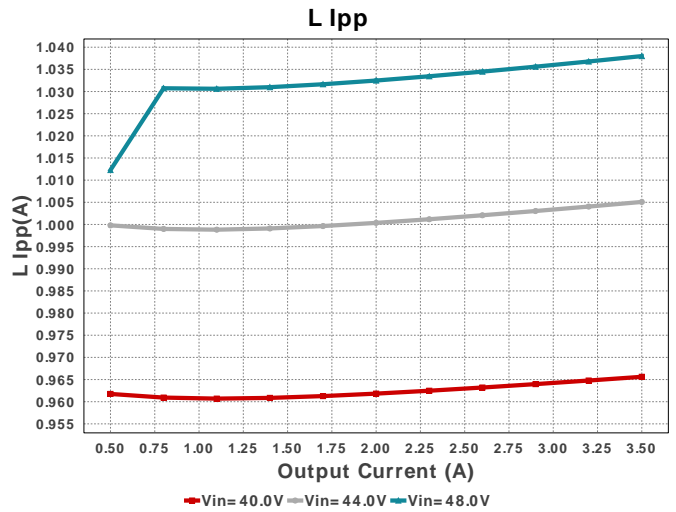
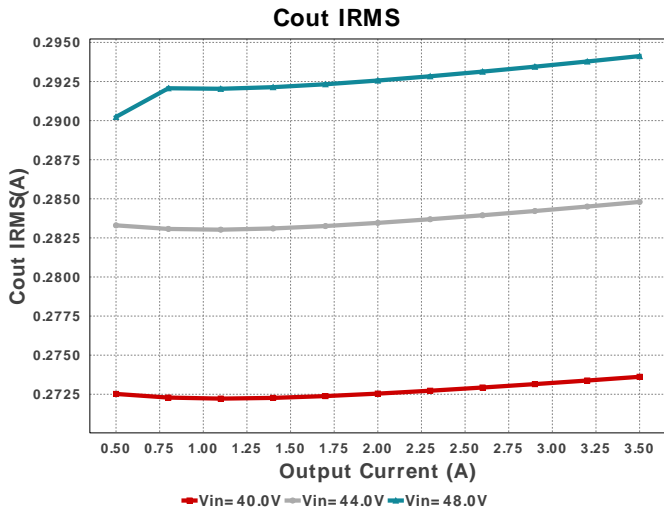

Operating Values

#	Name	Value	Category	Description
1.	BOM Count	16		Total Design BOM count
2.	Total BOM	\$6.065		Total BOM Cost
3.	Cin IRMS	1.537 A	Capacitor	Input capacitor RMS ripple current
4.	Cin Pd	5.006 mW	Capacitor	Input capacitor power dissipation
5.	Cout IRMS	294.125 mA	Capacitor	Output capacitor RMS ripple current
6.	Cout Pd	230.69 μW	Capacitor	Output capacitor power dissipation
7.	Coutx IRMS	5.518 mA	Capacitor	Output capacitor_x RMS ripple current
8.	Coutx Pd	334.16 nW	Capacitor	Output capacitor_x power loss
9.	IC Ipk	4.019 A	IC	Peak switch current in IC
10.	IC Pd	1.87 W	IC	IC power dissipation
11.	IC Tj	69.926 degC	IC	IC junction temperature

#	Name	Value	Category	Description
12.	IC Tolerance	19.0 mV	IC	IC Feedback Tolerance
13.	Iin Avg	921.3 mA	IC	Average input current
14.	Ipp percentage	29.657 %	Inductor	Inductor ripple current percentage (with respect to average inductor current)
15.	L Ipp	1.038 A	Inductor	Peak-to-peak inductor ripple current
16.	L Pd	345.51 mW	Inductor	Inductor power dissipation
17.	Cin Pd	5.006 mW	Power	Input capacitor power dissipation
18.	Cout Pd	230.69 μW	Power	Output capacitor power dissipation
19.	Coutx Pd	334.16 nW	Power	Output capacitor_x power loss
20.	IC Pd	1.87 W	Power	IC power dissipation
21.	L Pd	345.51 mW	Power	Inductor power dissipation
22.	Total Pd	2.223 W	Power	Total Power Dissipation
23.	Cross Freq	38.5 kHz	System	Bode plot crossover frequency
24.	Duty Cycle	25.725 %	System Information	Duty cycle
25.	Efficiency	94.974 %	System Information	Steady state efficiency
26.	FootPrint	480.0 mm ²	System Information	Total Foot Print Area of BOM components
27.	Frequency	400.0 kHz	System Information	Switching frequency
28.	Gain Marg	-12.271 dB	System Information	Bode Plot Gain Margin
29.	Iout	3.5 A	System Information	Iout operating point
30.	Low Freq Gain	62.35 dB	System Information	Gain at 1Hz
31.	Mode	CCM	System Information	Conduction Mode
32.	Phase Marg	45.695 deg	System Information	Bode Plot Phase Margin
33.	Pout	42.0 W	System Information	Total output power
34.	Vin	48.0 V	System Information	Vin operating point
35.	Vin p-p	530.977 mV	System Information	Peak-to-peak input voltage
36.	Vout	12.0 V	System Information	Operational Output Voltage
37.	Vout Actual	12.001 V	System Information	Vout Actual calculated based on selected voltage divider resistors
38.	Vout Tolerance	3.787 %	System Information	Vout Tolerance based on IC Tolerance (no load) and voltage divider resistors if applicable
39.	Vout p-p	12.723 mV	System Information	Peak-to-peak output ripple voltage
40.	PCB ICThetaJA	16.0 degC/W		Effective PCB ThetaJA

Design Inputs

Name	Value	Description
Iout	3.5	Maximum Output Current
VinMax	48.0	Maximum input voltage
VinMin	40.0	Minimum input voltage
Vout	12.0	Output Voltage
base_pn	LM76003	Base Product Number
source	DC	Input Source Type
Ta	40.0	Ambient temperature
UserFsw	400.0 k	Customer Selected Frequency

WEBENCH® Assembly

Component Testing

Some published data on components in datasheets such as Capacitor ESR and Inductor DC resistance is based on conservative values that will guarantee that the components always exceed the specification. For design purposes it is usually better to work with typical values. Since this data is not always available it is a good practice to measure the Capacitance and ESR values of C_{in} and C_{out} , and the inductance and DC resistance of L1 before assembly of the board. Any large discrepancies in values should be electrically simulated in WEBENCH to check for instabilities and thermally simulated in WebTHERM to make sure critical temperatures are not exceeded.

Soldering Component to Board

If board assembly is done in house it is best to tack down one terminal of a component on the board then solder the other terminal. For surface mount parts with large tabs, such as the DPAK, the tab on the back of the package should be pre-tinned with solder, then tacked into place by one of the pins. To solder the tab down to the board place the iron down on the board while resting against the tab, heating both surfaces simultaneously. Apply light pressure to the top of the plastic case until the solder flows around the part and the part is flush with the PCB. If the solder is not flowing around the board you may need a higher wattage iron (generally 25W to 30W is enough).

Initial Startup of Circuit

It is best to initially power up the board by setting the input supply voltage to the lowest operating input voltage 40.0V and set the input supply's current limit to zero. With the input supply off connect up the input supply to V_{in} and GND. Connect a digital volt meter and a load if needed to set the minimum load of the design from V_{out} and GND. Turn on the input supply and slowly turn up the current limit on the input supply. If the voltage starts to rise on the input supply continue increasing the input supply current limit while watching the output voltage. If the current increases on the input supply, but the voltage remains near zero, then there may be a short or a component misplaced on the board. Power down the board and visually inspect for solder bridges and recheck the diode and capacitor polarities. Once the power supply circuit is operational then more extensive testing may include full load testing, transient load and line tests to compare with simulation results.

Load Testing

The setup is the same as the initial startup, except that an additional digital voltmeter is connected between V_{in} and GND, a load is connected between V_{out} and GND and a current meter is connected in series between V_{out} and the load. The load must be able to handle at least rated output power + 50% (7.5 watts for this design). Ideally the load is supplied in the form of a variable load test unit. It can also be done in the form of suitably large power resistors. When using an oscilloscope to measure waveforms on the prototype board, the ground leads of the oscilloscope probes should be as short as possible and the area of the loop formed by the ground lead should be kept to a minimum. This will help reduce ground lead inductance and eliminate EMI noise that is not actually present in the circuit.



WEBENCH® Electrical Simulation Report

Design Id = 74

sim_id = 1

Simulation Type = Bode Plot

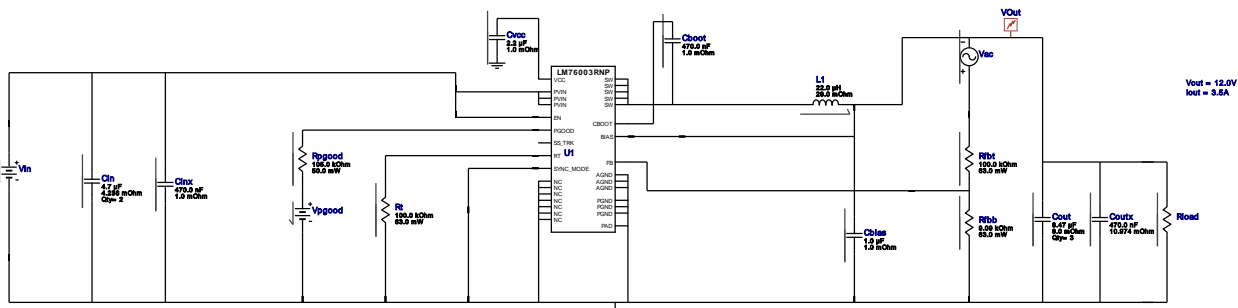

Simulation Parameters

#	Name	Parameter Name	Description	Values
1.	Vpgood	V	Supply Voltage	5 V
2.	Cin	IC	Initial condition	44.0 V
3.	Cinx	IC	Initial condition	44.0 V
4.	Coutx	IC	Initial condition	12.0 V
5.	Cout	IC	Initial condition	12.0 V
6.	Cinj	C	Injection isolation capacitance	10000000 F
7.	Linj	L	Injection isolation inductance	10000000 H
8.	Vinj	AC	AC signal	1 V
9.	Rload	R	Load_Resistance	3.4285714285714284 ohm

Bode Plot

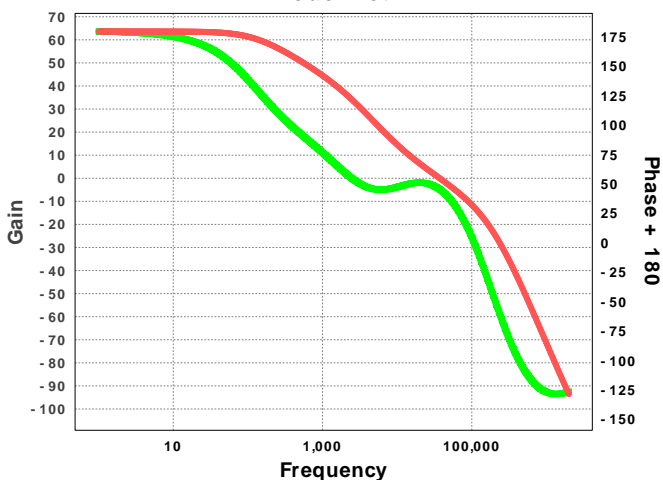

Design Id = 74

sim_id = 2

Simulation Type = Load Transient

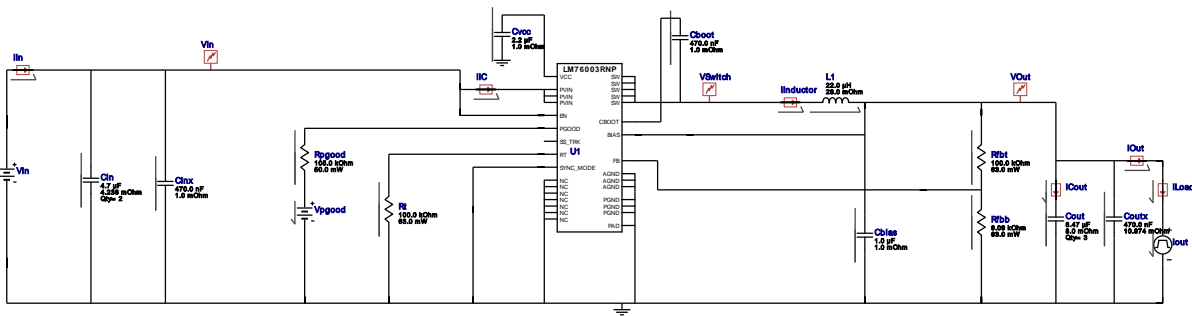

Simulation Parameters

#	Name	Parameter Name	Description	Values
1.	Vpgood	V	Supply Voltage	5 V
2.	L1	IC	Initial condition	-3.5 V
3.	Cboot	IC	Initial condition	10 V
4.	Iout	signal_type	Signal Type	PULSE
		I1	Initial Load Current	3.5 A
		I2	Minimum Load Current	0.35 A
		Td	Initial Time Delay	2.0E-4 s
		Tf	Fall Time	10 µs
		Tr	Rise Time	10 µs
		Pw	Pulse Width	7.0E-4 s

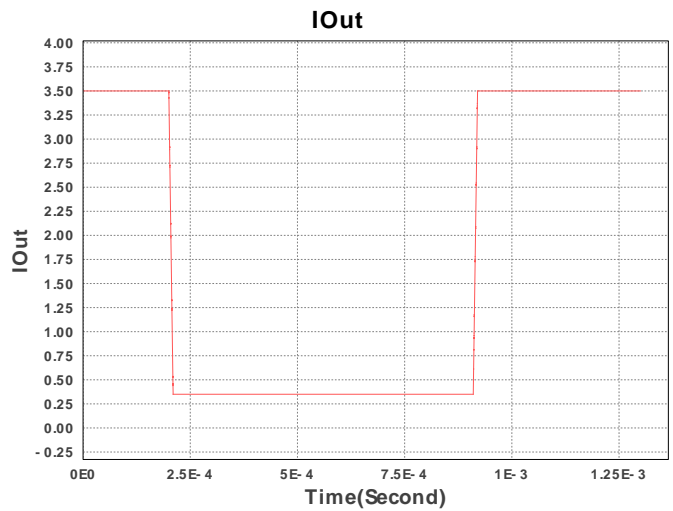
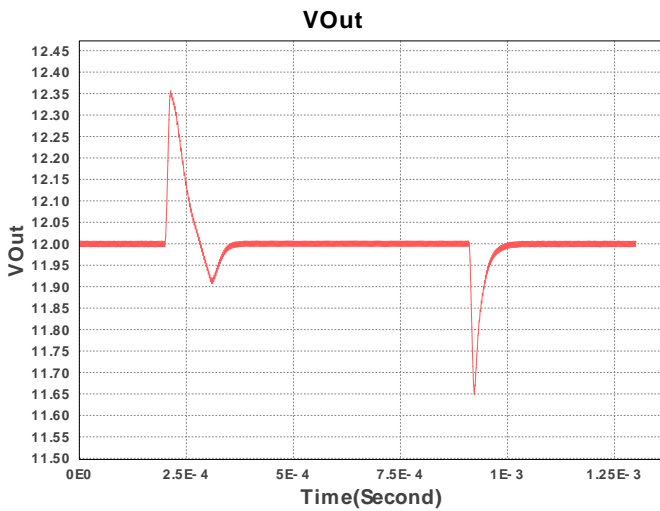

Design Id = 74

sim_id = 3

Simulation Type = Input Transient

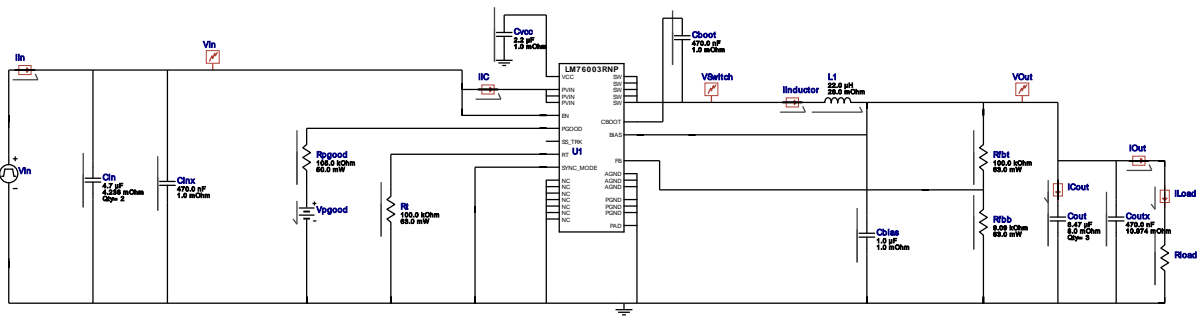

Simulation Parameters

#	Name	Parameter Name	Description	Values
1.	Vpgood	V	no description	5 V
2.	Cvcc	IC	Initial condition	3.15 V
3.	L1	IC	Initial condition	0 V
4.	Cboot	IC	Initial condition	10 V
5.	Rload	R	Load Resistance	3.4285714285714284 Ohm

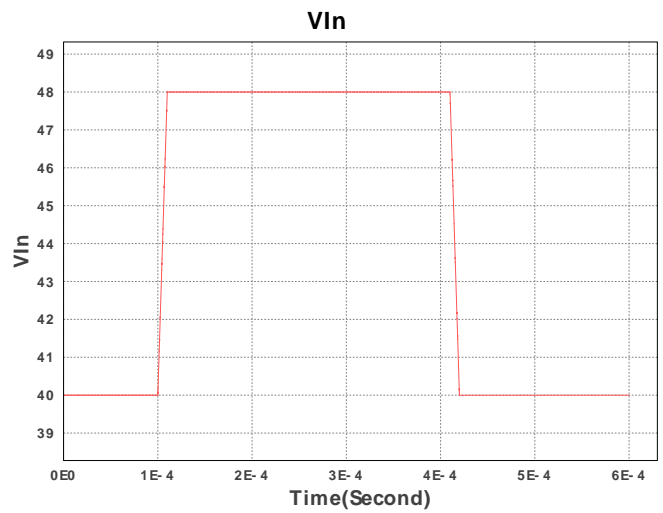
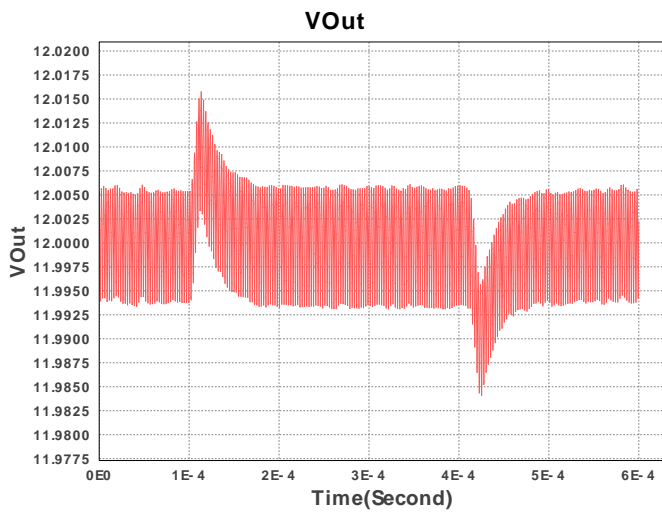

Design Id = 74

sim_id = 4

Simulation Type = Steady State

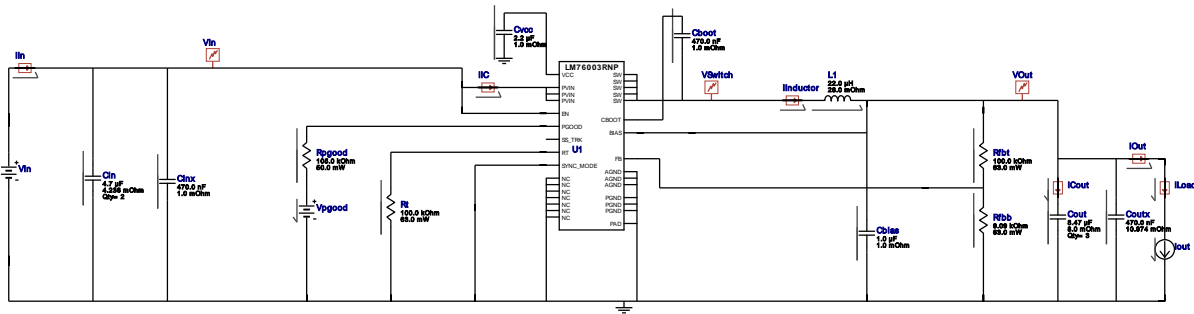

Simulation Parameters

#	Name	Parameter Name	Description	Values
1.	Vpgood	V	Pgood Voltage	5
2.	Vz_sync	Vin	no description	0
3.	L1	IC	Initial Current	-3.5
4.	Cboot	IC	Initial condition	10 V
5.	Iout	I	Load Current	3.5 A

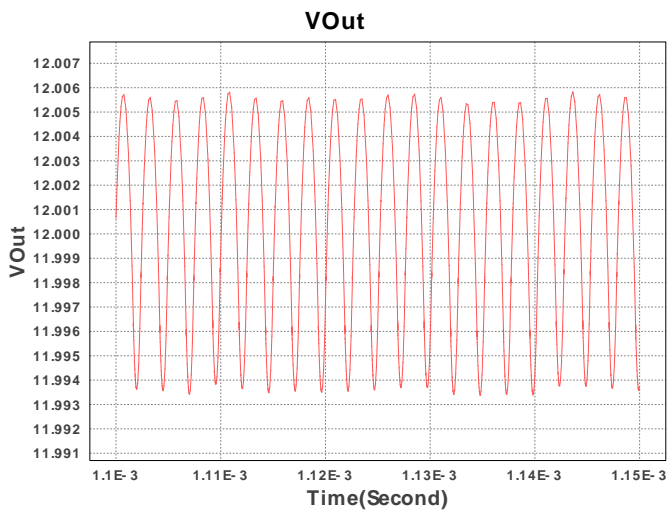

Design Assistance

1. Master key : 15882B5FF9AD5C05[v1]
2. **LM76003** Product Folder : <http://www.ti.com/product/LM76003> : contains the data sheet and other resources.

Important Notice and Disclaimer

TI provides technical and reliability data (including datasheets), design resources (including reference designs), application or other design advice, web tools, safety information, and other resources AS IS and with all faults, and disclaims all warranties. These resources are intended for skilled developers designing with TI products. You are solely responsible for (1) selecting the appropriate TI products for your application, (2) designing, validating and testing your application, and (3) ensuring your application meets applicable standards, and any other safety, security, or other requirements.

These resources are subject to change without notice. TI grants you permission to use these resources only for development of an application that uses the TI products described in the resource. Other reproduction and display of these resources is prohibited. No license is granted to any other TI intellectual property right or to any third party intellectual property right. TI disclaims responsibility for, and you will fully indemnify TI and its representatives against, any claims, damages, costs, losses, and liabilities arising out of your use of these resources.

Providing these resources does not expand or otherwise alter TI's applicable Terms of Sale or other applicable terms available either on ti.com or provided in conjunction with TI products.