

VinMin = 20.0V  
 VinMax = 28.0V  
 Vout = 12.0V  
 Iout = 5.0A

Device = LMR14050SSQDDARQ1  
 Topology = Buck  
 Created = 2023-03-06 23:00:16.075  
 BOM Cost = \$3.64  
 BOM Count = 12  
 Total Pd = 5.02W

# WEBENCH® Design Report

Design : 8536 LMR14050SSQDDARQ1  
 LMR14050SSQDDARQ1 20V-28V to 12.00V @ 5A

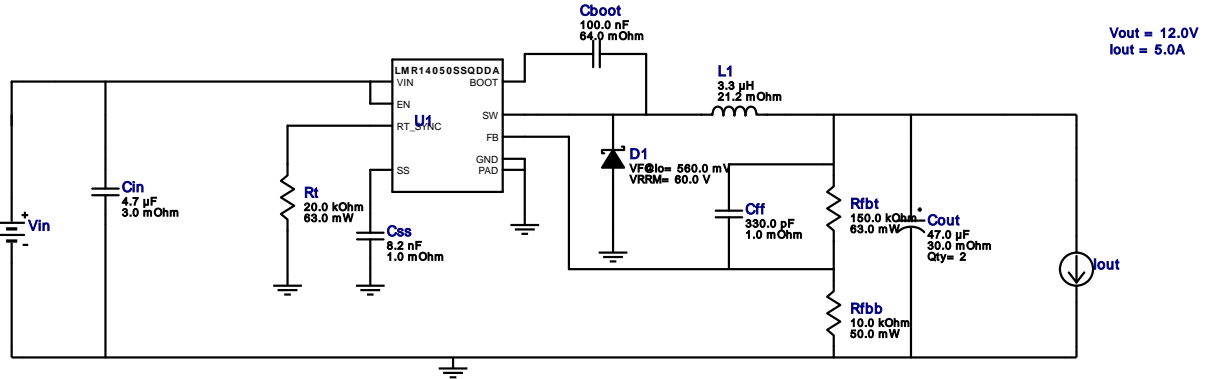

1. This regulator device is qualified for Automotive applications. All passives and other components selected in this design may not be qualified for Automotive applications. The user is required to verify that all components in the design meet the qualification and safety requirements for their specific application. View WEBENCH(R) Disclaimer.

## Design Alerts

### Component Selection Information

The LMR14050SS-Q1 is qualified for Automotive applications. All passives and other components selected in this design may not be qualified for Automotive applications. The user is required to verify that all components in the design meet the qualification and safety requirements for their specific application. LMR14050SS-Q1 is a Spread Spectrum option for reduced EMI. For additional information or assistance regarding the frequency dithering, please contact your local TI FAE.

## Electrical BOM

Name	Manufacturer	Part Number	Properties	Qty	Price	Footprint
Cboot	Kemet	C0805C104M5RACTU Series= X7R	Cap= 100.0 nF ESR= 64.0 mOhm VDC= 50.0 V IRMS= 1.64 A	1	\$0.01	0805 7 mm <sup>2</sup>
Cff	MuRata	GRM033R71E331KA01D Series= X7R	Cap= 330.0 pF ESR= 1.0 mOhm VDC= 25.0 V IRMS= 0.0 A	1	\$0.01	0201 2 mm <sup>2</sup>
Cin	MuRata	GRM31CR71H475KA12L Series= X7R	Cap= 4.7 uF ESR= 3.0 mOhm VDC= 50.0 V IRMS= 4.98 A	1	\$0.10	1206 11 mm <sup>2</sup>
Cout	Panasonic	25SVPF47M Series= SVPF	Cap= 47.0 uF ESR= 30.0 mOhm VDC= 25.0 V IRMS= 2.8 A	2	\$0.57	CAPSMT_62_F61 74 mm <sup>2</sup>
Css	MuRata	GRM155R71C822KA01D Series= X7R	Cap= 8.2 nF ESR= 1.0 mOhm VDC= 16.0 V IRMS= 0.0 A	1	\$0.01	0402 3 mm <sup>2</sup>
D1	Diodes Inc.	PDS760-13	VF@Io= 560.0 mV VRRM= 60.0 V	1	\$0.34	PowerDi5 50 mm <sup>2</sup>
L1	Coilcraft	XAL5030-332MEB	L= 3.3 µH 21.2 mOhm	1	\$0.63	XAL5030 54 mm <sup>2</sup>

Name	Manufacturer	Part Number	Properties	Qty	Price	Footprint
Rfbb	Yageo	RC0201FR-0710KL Series= ?	Res= 10.0 kOhm Power= 50.0 mW Tolerance= 1.0%	1	\$0.01	0201 2 mm <sup>2</sup>
Rfbt	Vishay-Dale	CRCW0402150KFKED Series= CRCW..e3	Res= 150.0 kOhm Power= 63.0 mW Tolerance= 1.0%	1	\$0.01	0402 3 mm <sup>2</sup>
Rt	Vishay-Dale	CRCW040220K0FKED Series= CRCW..e3	Res= 20.0 kOhm Power= 63.0 mW Tolerance= 1.0%	1	\$0.01	0402 3 mm <sup>2</sup>
U1	Texas Instruments	LMR14050SSQDDARQ1	Switcher	1	\$1.37	 DDA0008E_N 55 mm <sup>2</sup>

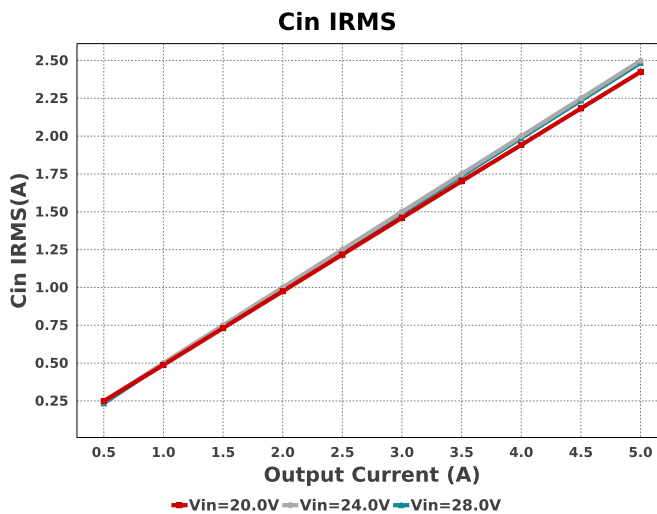
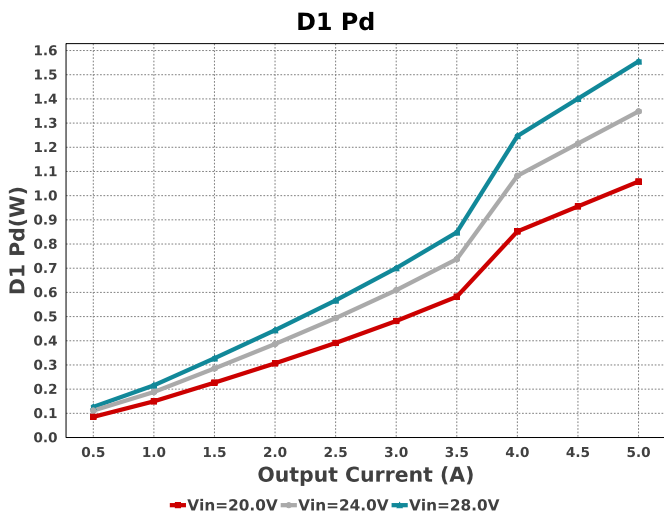
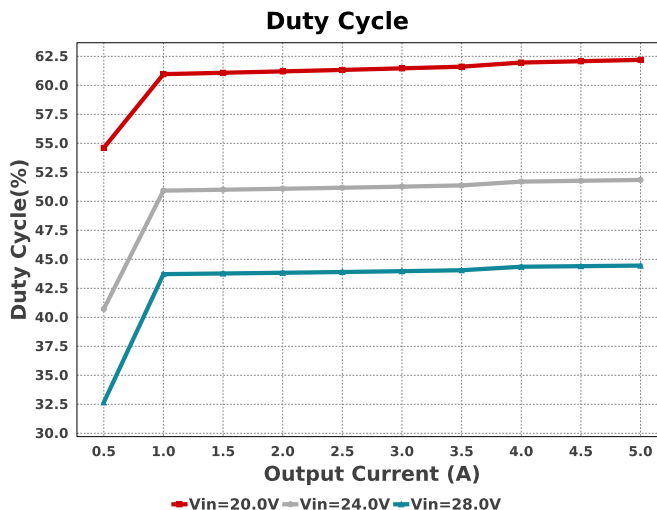
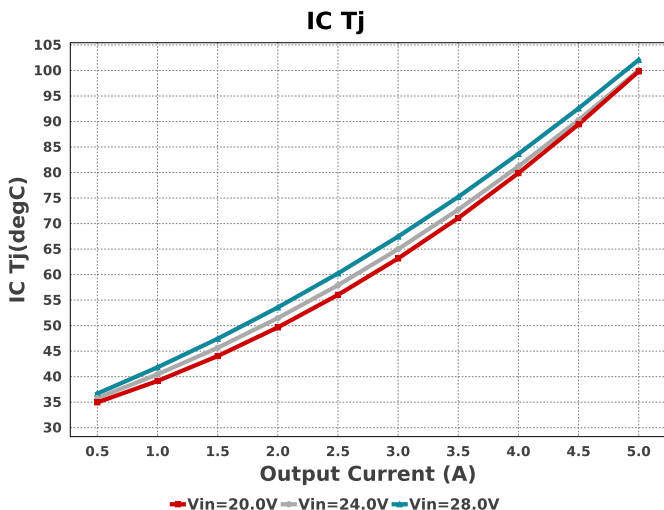

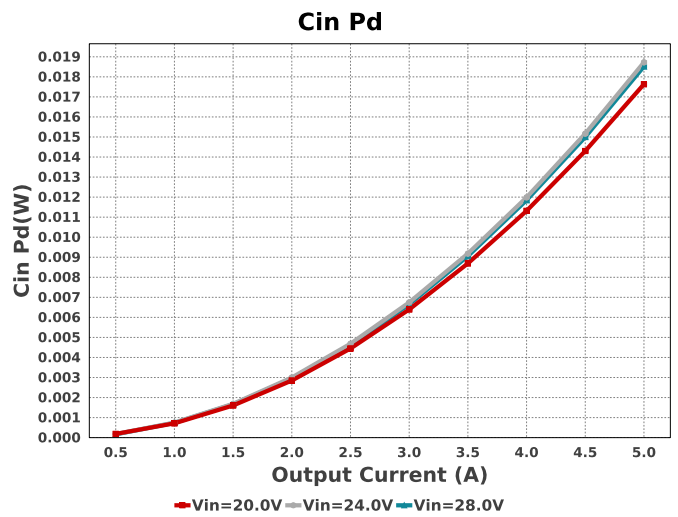
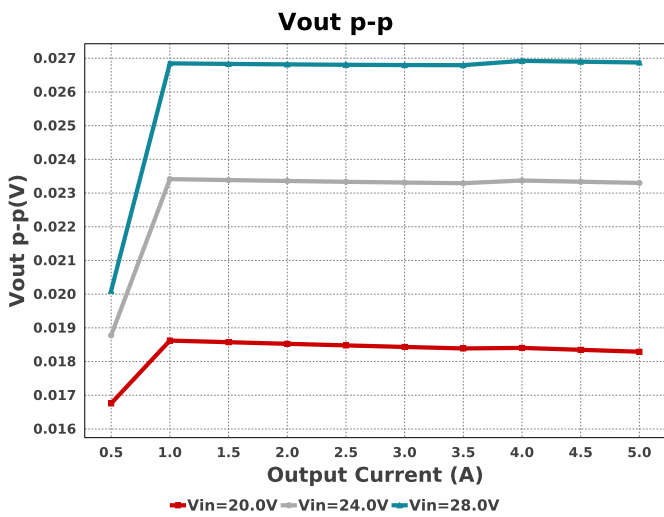
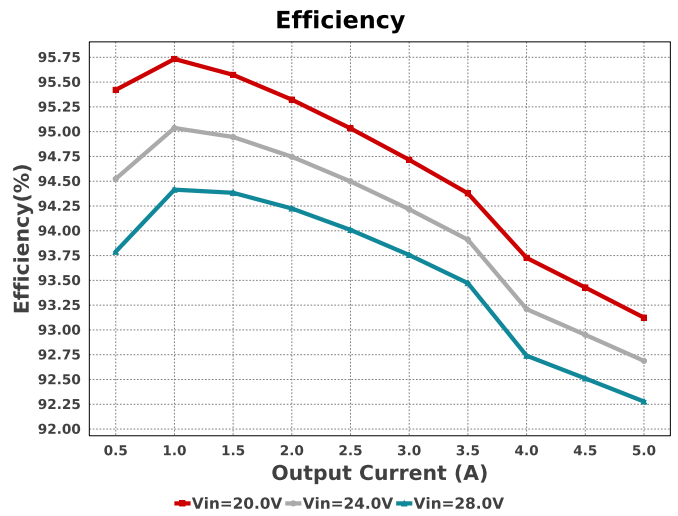
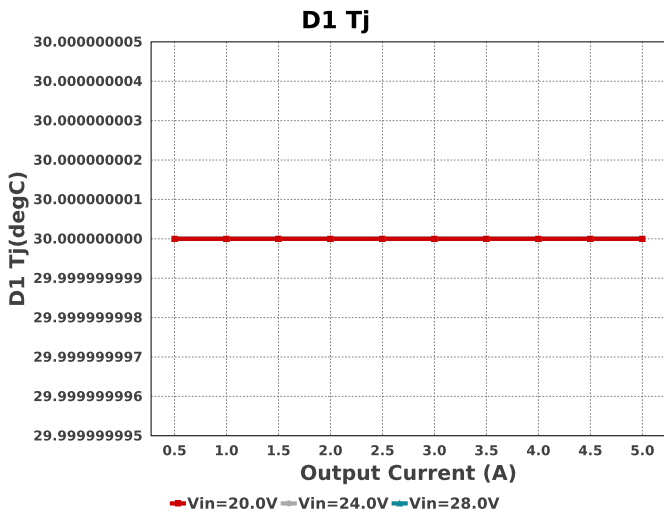
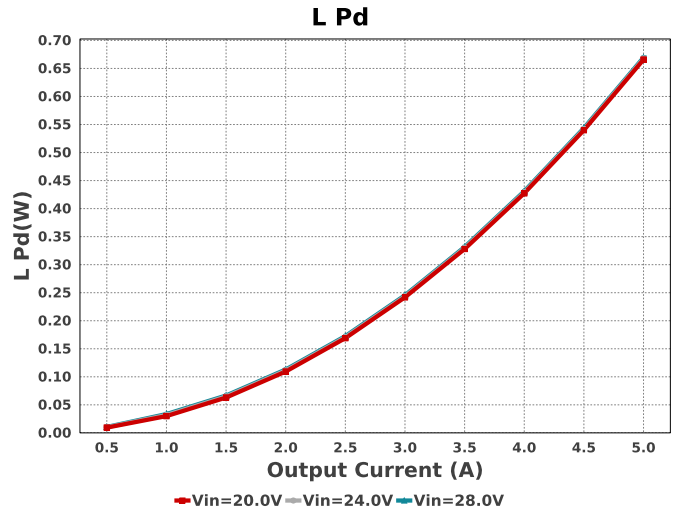
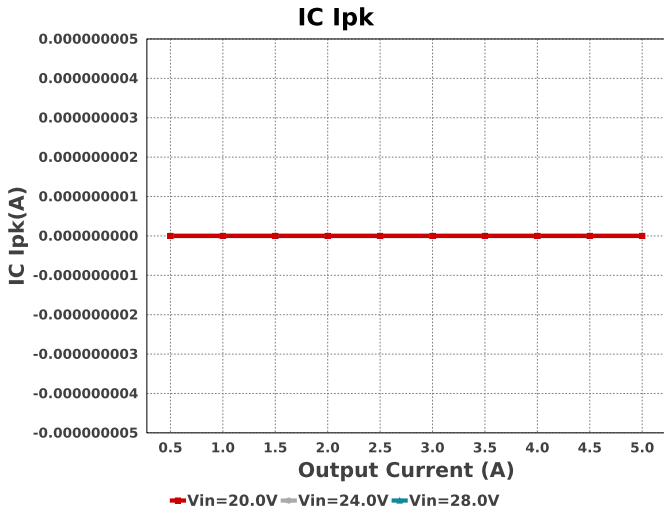

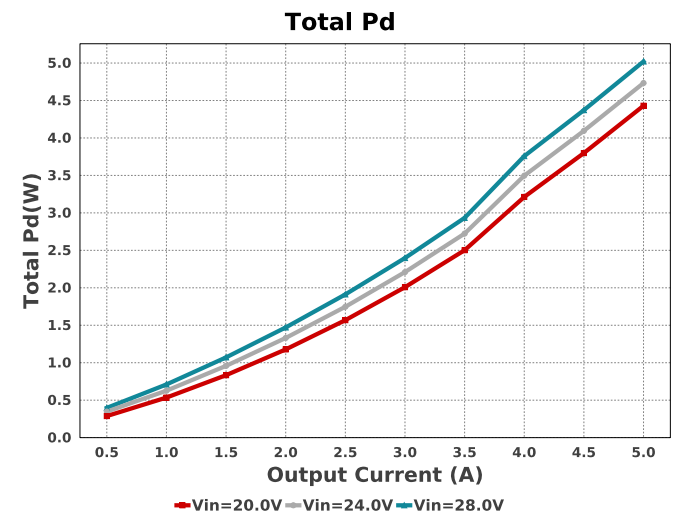
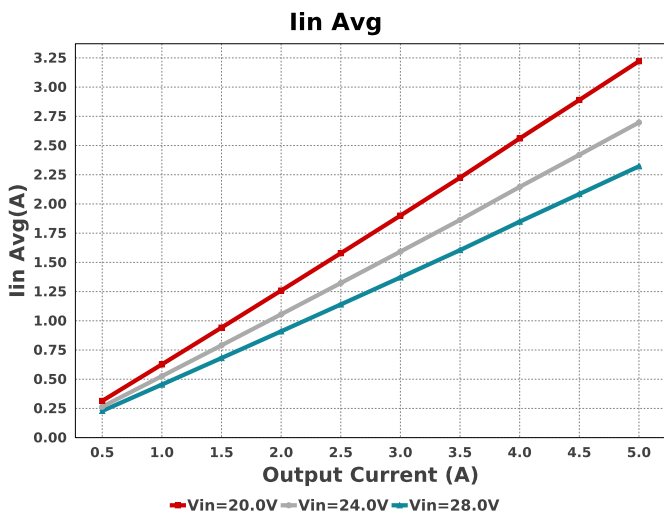
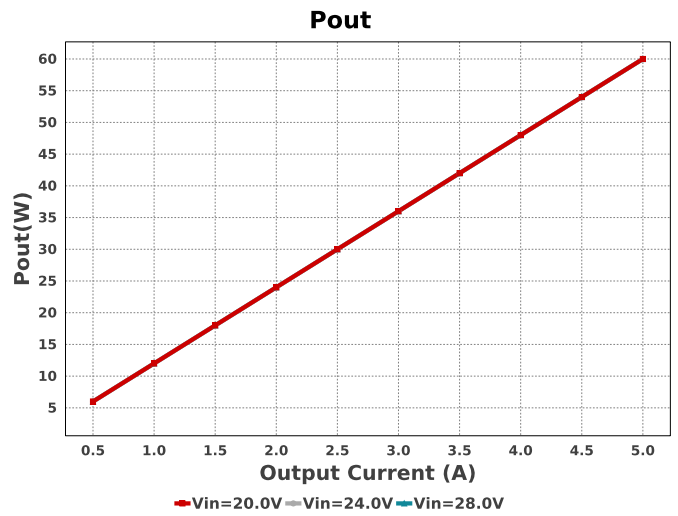
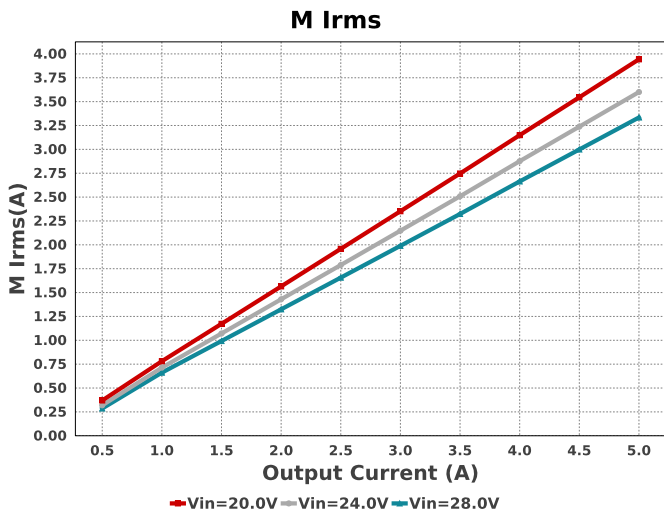
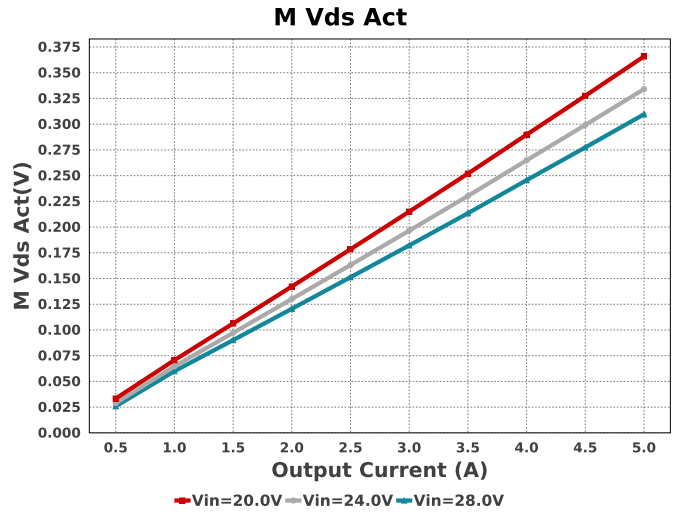
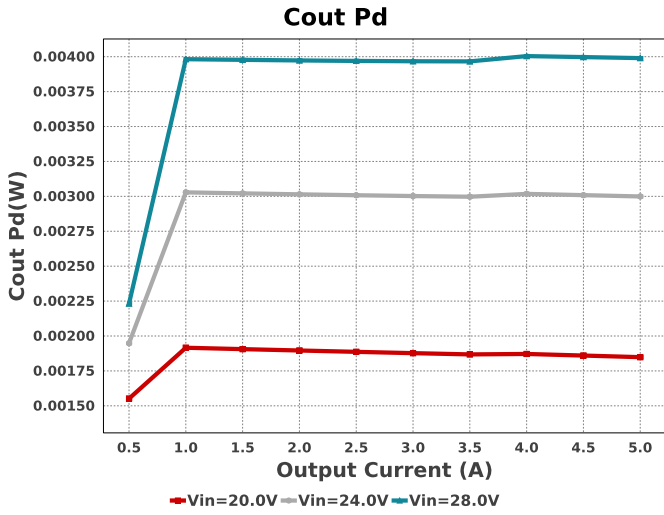

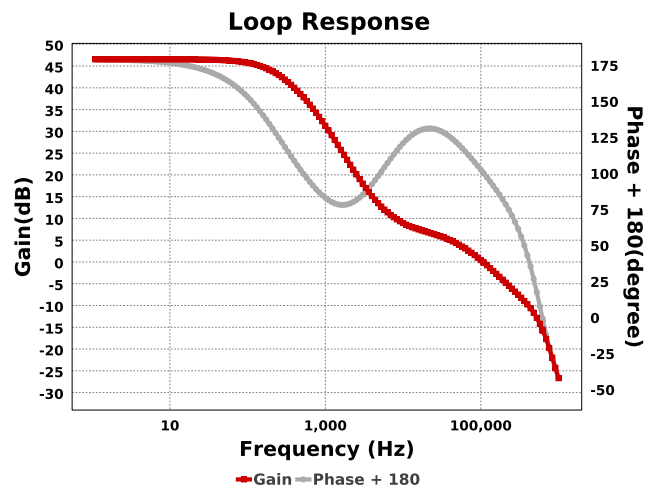
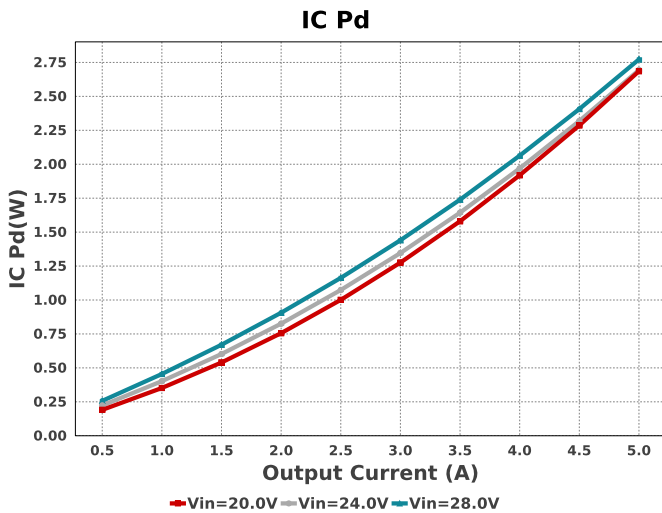
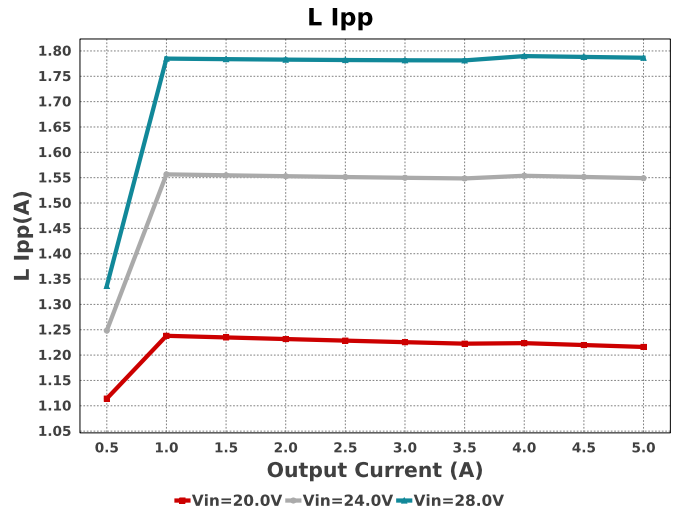
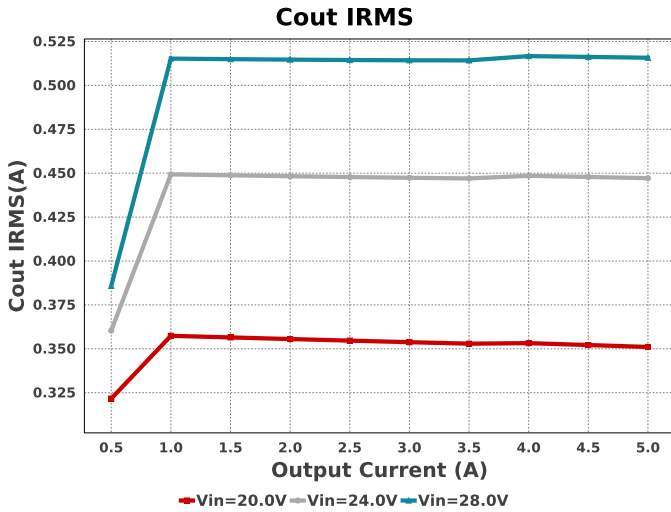

### Operating Values

#	Name	Value	Category	Description
1.	Cin IRMS	2.485 A	Capacitor	Input capacitor RMS ripple current
2.	Cin Pd	18.52 mW	Capacitor	Input capacitor power dissipation
3.	Cout IRMS	515.745 mA	Capacitor	Output capacitor RMS ripple current
4.	Cout Pd	3.99 mW	Capacitor	Output capacitor power dissipation
5.	D1 Pd	1.555 W	Diode	Output Diode Power Dissipation
6.	D1 Tj	138.86 degC	Diode	D1 junction temperature
7.	IC Ipk	0.0 A	IC	Peak switch current in IC
8.	IC Pd	2.772 W	IC	IC power dissipation
9.	IC Tj	102.086 degC	IC	IC junction temperature
10.	IC Tolerance	18.0 mV	IC	IC Feedback Tolerance
11.	ICThetaJA	26.0 degC/W	IC	IC junction-to-ambient thermal resistance
12.	Iin Avg	2.322 A	IC	Average input current
13.	L Ipp	1.787 A	Inductor	Peak-to-peak inductor ripple current
14.	L Pd	669.55 mW	Inductor	Inductor power dissipation
15.	M Irms	3.334 A	Mosfet	MOSFET RMS ripple current
16.	M Vds Act	309.558 mV	Mosfet	Voltage drop across the MosFET
17.	Cin Pd	18.52 mW	Power	Input capacitor power dissipation
18.	Cout Pd	3.99 mW	Power	Output capacitor power dissipation
19.	D1 Pd	1.555 W	Power	Output Diode Power Dissipation
20.	IC Pd	2.772 W	Power	IC power dissipation
21.	L Pd	669.55 mW	Power	Inductor power dissipation
22.	Total Pd	5.021 W	Power	Total Power Dissipation
23.	BOM Count	12	System	Total Design BOM count
24.	Cross Freq	106.834 kHz	System	Bode plot crossover frequency
25.	Duty Cycle	44.459 %	System	Duty cycle
26.	Efficiency	92.278 %	System	Steady state efficiency

#	Name	Value	Category	Description
27.	FootPrint	338.0 mm <sup>2</sup>	System Information	Total Foot Print Area of BOM components
28.	Frequency	1.183 MHz	System Information	Switching frequency
29.	Gain Marg	-15.562 dB	System Information	Bode Plot Gain Margin
30.	Iout	5.0 A	System Information	Iout operating point
31.	Low Freq Gain	46.545 dB	System Information	Gain at 1Hz
32.	Mode	CCM	System Information	Conduction Mode
33.	Phase Marg	101.16 deg	System Information	Bode Plot Phase Margin
34.	Pout	60.0 W	System Information	Total output power
35.	Total BOM	\$3.64	System Information	Total BOM Cost
36.	Vin	28.0 V	System Information	Vin operating point
37.	Vout	12.0 V	System Information	Operational Output Voltage
38.	Vout Actual	12.0 V	System Information	Vout Actual calculated based on selected voltage divider resistors
39.	Vout Tolerance	4.339 %	System Information	Vout Tolerance based on IC Tolerance (no load) and voltage divider resistors if applicable
40.	Vout p-p	26.874 mV	System Information	Peak-to-peak output ripple voltage

## Design Inputs

Name	Value	Description
Iout	5.0	Maximum Output Current
VinMax	28.0	Maximum input voltage
VinMin	20.0	Minimum input voltage
Vout	12.0	Output Voltage
base_pn	LMR14050SS-Q1	Base Product Number
source	DC	Input Source Type
Ta	30.0	Ambient temperature

## WEBENCH® Assembly

### Design Assistance

1. Master key : AE3011FD2EE8F4EB[v1]
2. **LMR14050SS-Q1** Product Folder : <http://www.ti.com/product/LMR14050%2DQ1> : contains the data sheet and other resources.

#### Important Notice and Disclaimer

TI provides technical and reliability data (including datasheets), design resources (including reference designs), application or other design advice, web tools, safety information, and other resources AS IS and with all faults, and disclaims all warranties. These resources are intended for skilled developers designing with TI products. You are solely responsible for (1) selecting the appropriate TI products for your application, (2) designing, validating and testing your application, and (3) ensuring your application meets applicable standards, and any other safety, security, or other requirements.

These resources are subject to change without notice. TI grants you permission to use these resources only for development of an application that uses the TI products described in the resource. Other reproduction and display of these resources is prohibited. No license is granted to any other TI intellectual property right or to any third party intellectual property right. TI disclaims responsibility for, and you will fully indemnify TI and its representatives against, any claims, damages, costs, losses, and liabilities arising out of your use of these resources.

Providing these resources does not expand or otherwise alter TI's applicable Terms of Sale or other applicable terms available either on ti.com or provided in conjunction with TI products.