

# Power

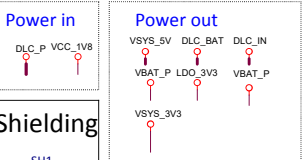

## DC-DC Buck 60V/ 5V,10A

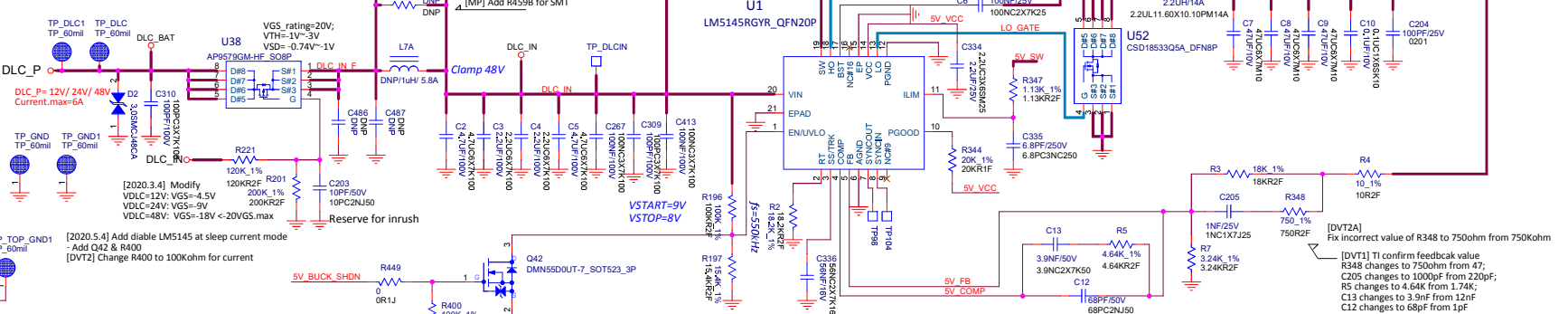

## DC-DC Buck LM76003RNPRQ1 (w/ EPAD)

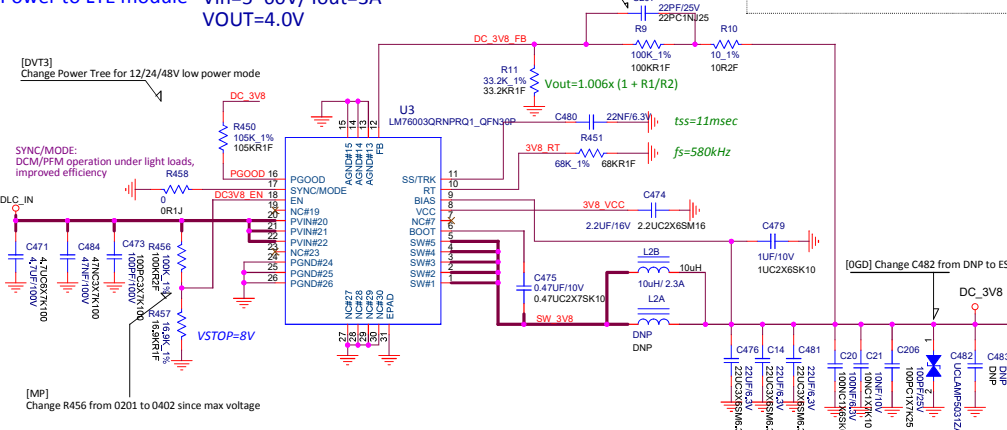

## DC-DC Buck Power to WiFi/BT

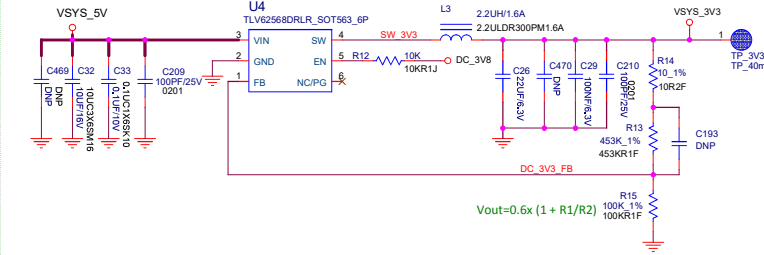

## Power MUX: DC-DC 3V8 and BAT

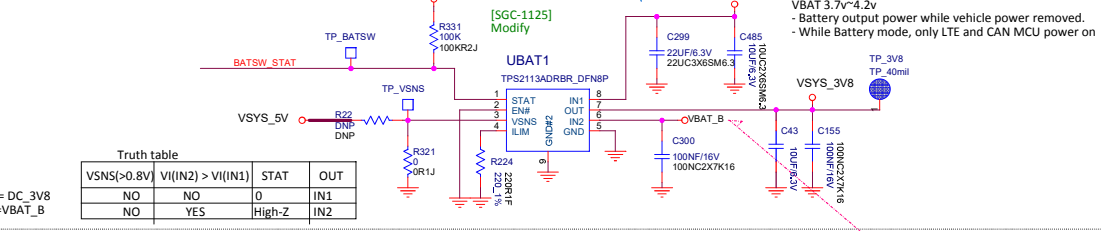

## LDO Power to CAN MCU

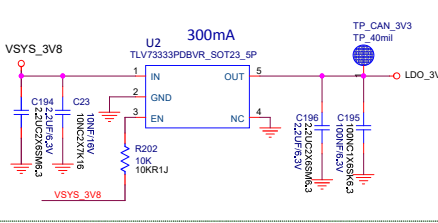

## Backup Power: supercap

