

schematics

Lm5036 control and aux power configurations

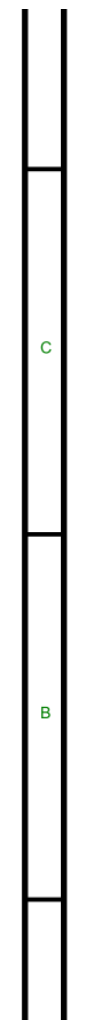
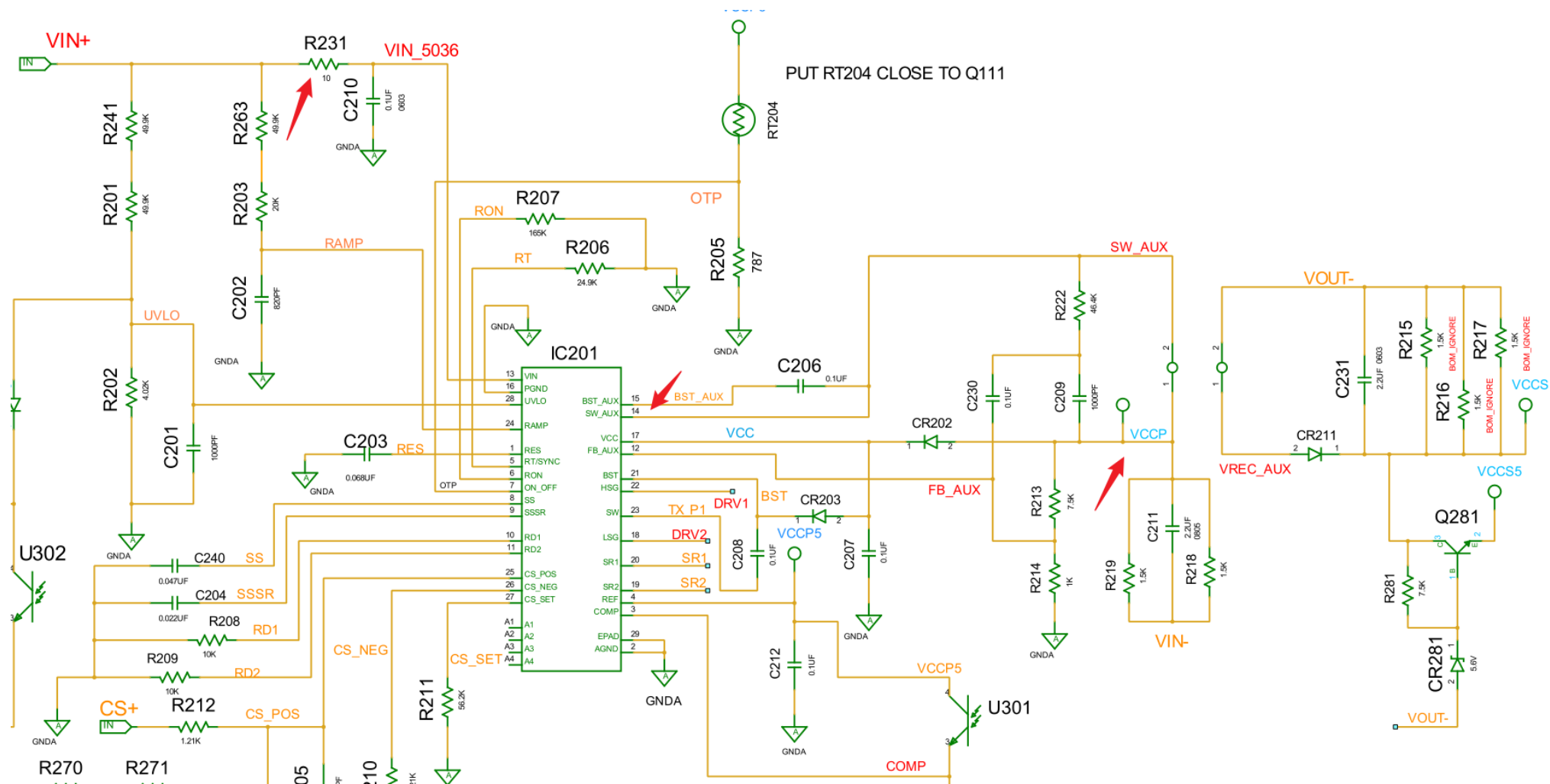

Test conditions

- Power on & off test applied to the auxiliary power within LM5036 ONLY
- Half-bridge power stage was set to OFF

- Temperature: -40C
- under V_{in} 36V and 75V
- 1s on and 1s off, run for ~12hours
- Qty: 2pcs

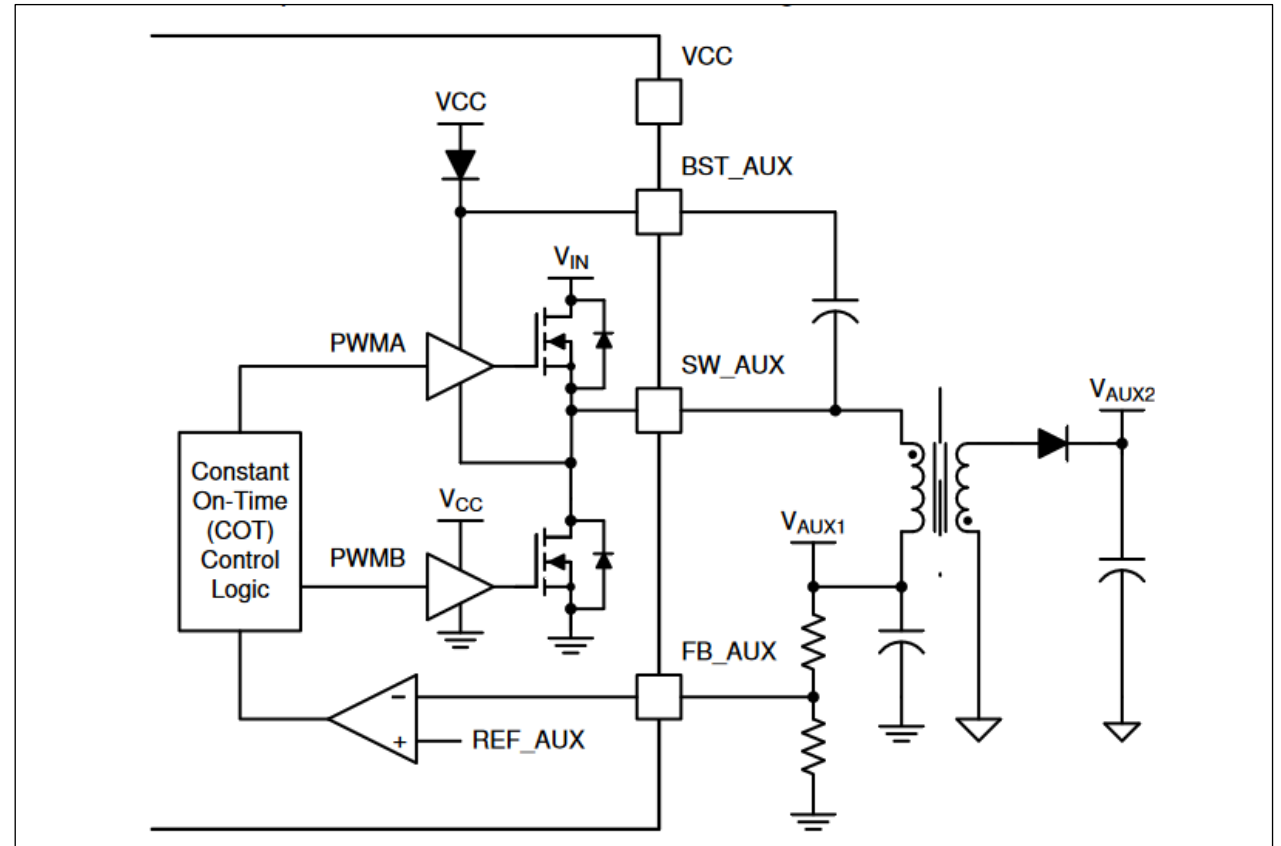

Issue description

Abnormal auxiliary power supply output was found after 12hr turn on and turn off under -40C

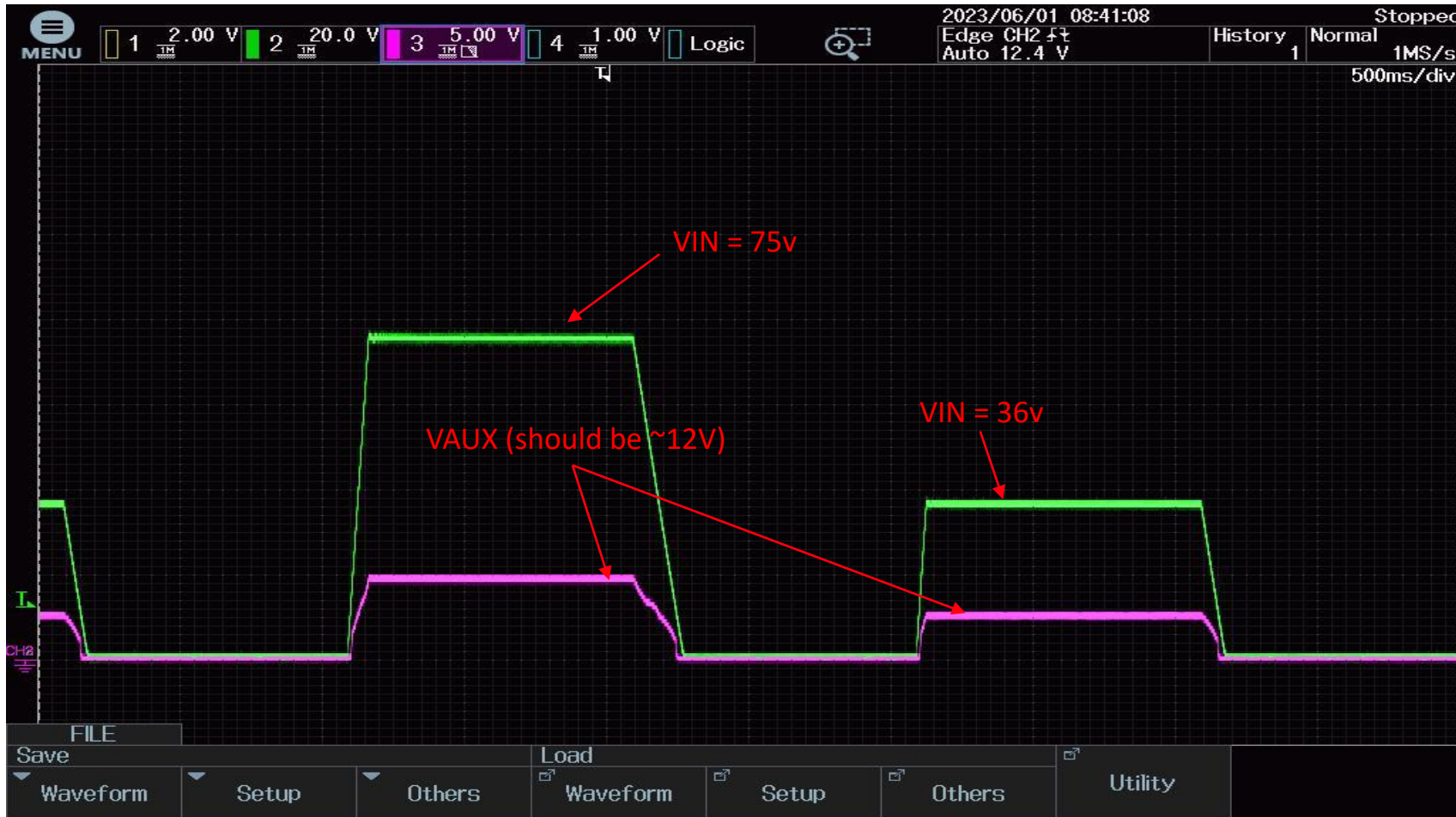

Failed unit at 48Vin



Good unit at 48Vin (signal for reference)

