



Chuangxin Online Test Center Laboratory

Add: F/r 401 Building A, Ying Da Feng industrial No,393,Jihua Rd.LongGang
Dis. Shenzhen China
Tel: 0755-83765367 Email: taow@iclab-cn.com



Report No:	SZ07282021001
Date:	2021/07/28
Page:	1/10

Project Inspection Report

Company : Beijing Yuanda Innovation Technologies Ltd.
Address : Room 506, Building 1, No.10 Caihefang Road, Haidian District, Beijing
Sample Name : LMZ14203
Manufacture : TI
Date Code : N/A
Package Type : SMT-TO
Sample Number : 4 PCS
Check Number : 4 PCS
Date of Received : 07/19/2021
Date of Tested : 07/19/2021 ~ 07/27/2021

WE HEREBY CERTIFY THAT:

The test(s) shown in the attachment were conducted according to the indicating procedures. We assume full responsibility for the accuracy and completeness of these tests and vouch for the qualifications of all personnel performing them.

Inspected by Engineer
Wei-Tao

Reviewed by Project Manager
Felix

Note:

1. This report will be invalid if reproduced in whole or in part.
2. This report refers only to the specimen(s) submitted to test, and is invalid if used separately.
3. This report is only valid with the examination seal and signature of this institute.
4. The tested specimen(s) will only be preserved for thirty days from the date issued, if not collected by the applicant.
5. This report is only responsible for the samples tested.



Chuangxin Online Test Center Laboratory

Add: F/r 401 Building A, Ying Da Feng industrial No,393,Jihua Rd.LongGang
Dis. Shenzhen China
Tel: 0755-83765367 Email: taow@iclab-cn.com



Report No:	SZ07282021001
Date:	2021/07/28
Page:	2/10

Items test

- External visual inspection
- Pin Correlation Test
- Programming test
- Solder ability Analysis
- Radiography (X-ray)
- ROHS test
- Key Functional Testing (KFT)
- Baking
- Tape and Reel
- Internal visual inspection
- Top permanency test

Methods & Equipment

1.1 Applicable Standard

- MIL-STD-883K-2017 2037

1.2 Optical Microscope

- Equipment Spec.:
Top view: FINIAL Hi-scope System SEZ-260: X7 ~ X45

1.3 Radiography (X-ray)

- Equipment Spec:
Hardware: XiDAT Dage XD6500
Software: 11.56-DD6058
Magnification in excess of 2800x
Resolution below 2um
Energy: 60KV/40uA

1.4 Testing Environment

- Ambient Temperature: 25±5°C
- Relative Humidity: 45%-65% RH



Chuangxin Online Test Center Laboratory

Add: F/r 401Building A, Ying Da Feng industrial No,393,Jihua Rd.LongGang
Dis. Shenzhen China
Tel: 0755-83765367 Email: taow@iclab-cn.com



Report No:	SZ07282021001
Date:	2021/07/28
Page:	3/10

1.5 Testing Base

[TI LMZ14203]

https://www.ti.com.cn/cn/lit/ds/symlink/lmz14203.pdf?ts=1627457882485&ref_url=https%253A%252F%252Fwww.ti.com.cn%252Fproduct%252Fcn%252FLMZ14203

X-ray Analysis:

Applicable Standard: MIL-STD-883K-2017 2037

X-ray inspection on 4PCS (G1,G2,F1,F2)samples, showed that there might be abnormal silver glue in the area around G1, G2, F1, F2 Die. The internal welding cavity rate of G1,G2,F1,F2 is abnormal, and the welding cavity rate is G1-29.987,G2-39.215,F1-34.242,F2-39.197.

F2 found suspected abnormal adhesion.



Report No:	SZ07282021001
Date:	2021/07/28
Page:	4/10

1. Device Description:

LMZ14203 SIMPLE SWITCHER power module is easy to use step-down dc/dc solution that can drive up to 3 a load,And have excellent power conversion efficiency, line and load regulation and output precision. LMZ14203 adopt innovative packaging, can improve the thermal performance and allows manually and welding machine.

2. Package Dimensions:

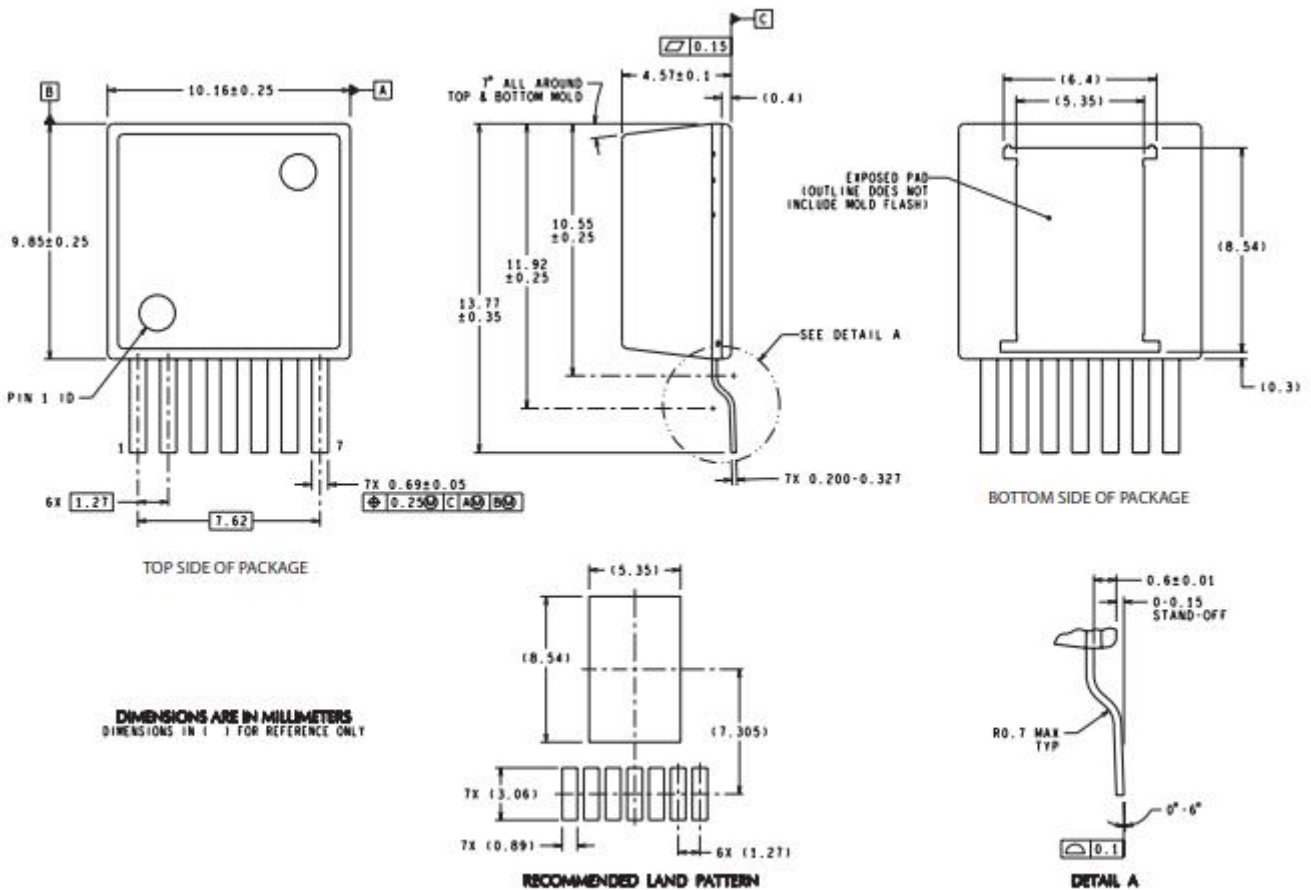



Chuangxin Online Test Center Laboratory

Add: F/r 401Building A, Ying Da Feng industrial No,393,Jihua Rd.LongGang
Dis. Shenzhen China
Tel: 0755-83765367 Email: taow@iclab-cn.com



Report No:	SZ07282021001
Date:	2021/07/28
Page:	5/10

3. Receiving Inspection:

Gross Weight	50g	Parts Total	4 PCS
Number Of Boxes	N/A	Full Label	Non Present
Package type	Bulk	Moisture protection	Non Present
MSL	N/A	ESD protection	Non Present

Received View





Report No:	SZ07282021001
Date:	2021/07/28
Page:	6/10

4.X-ray Analysis:

Applicable Standard: MIL-STD-883K-2017 2037

X-ray inspection on 4PCS (G1,G2,F1,F2)samples, showed that there might be abnormal silver glue in the area around G1, G2, F1, F2 Die. The internal welding cavity rate of G1,G2,F1,F2 is abnormal, and the welding cavity rate is G1-29.987,G2-39.215,F1-34.242,F2-39.197.

F2 found suspected abnormal adhesion.

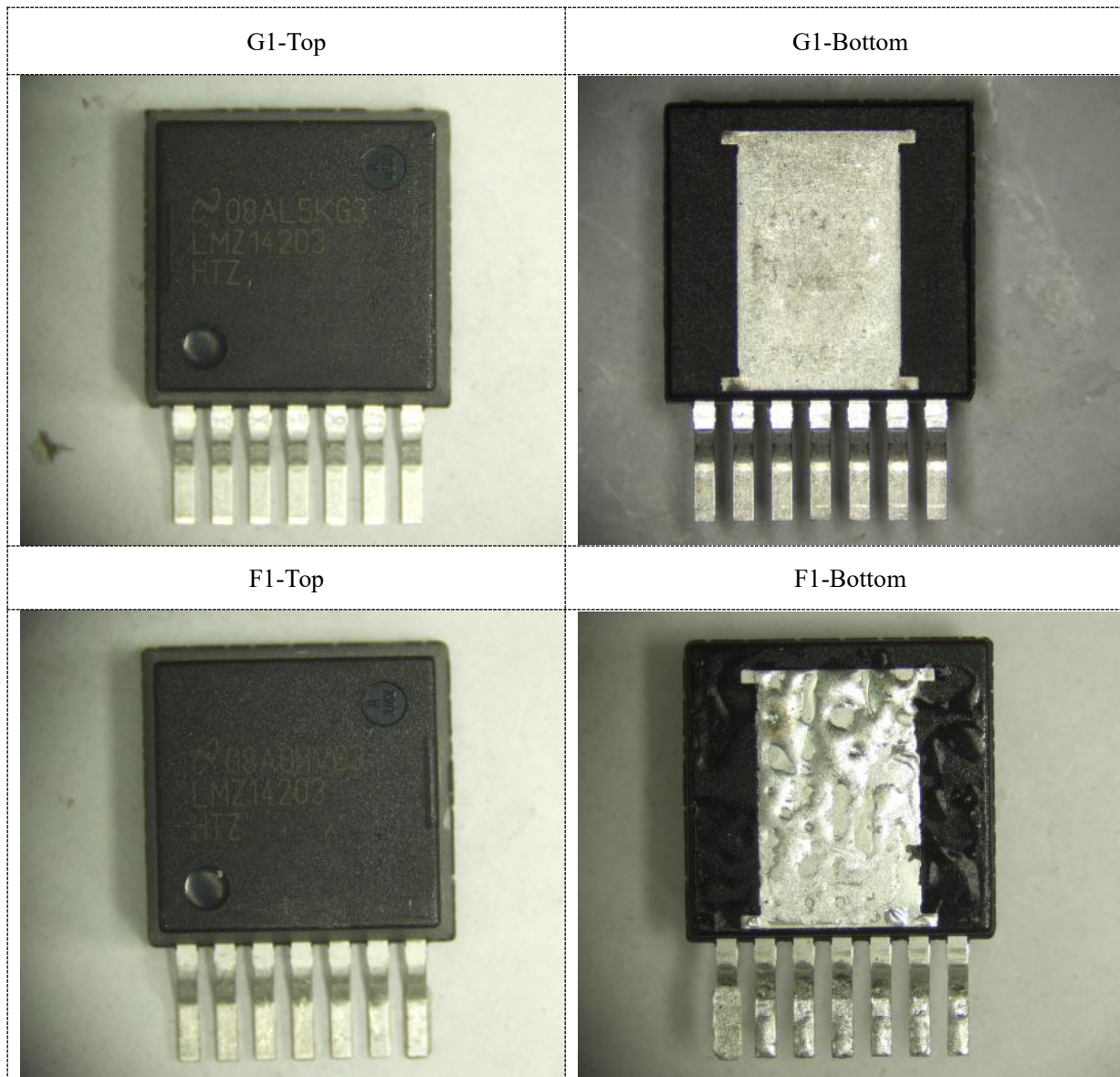



Chuangxin Online Test Center Laboratory

Add: F/r 401Building A, Ying Da Feng industrial No,393,Jihua Rd.LongGang
Dis. Shenzhen China
Tel: 0755-83765367 Email: taow@iclab-cn.com



Report No:	SZ07282021001
Date:	2021/07/28
Page:	7/10

G1-Top View-All

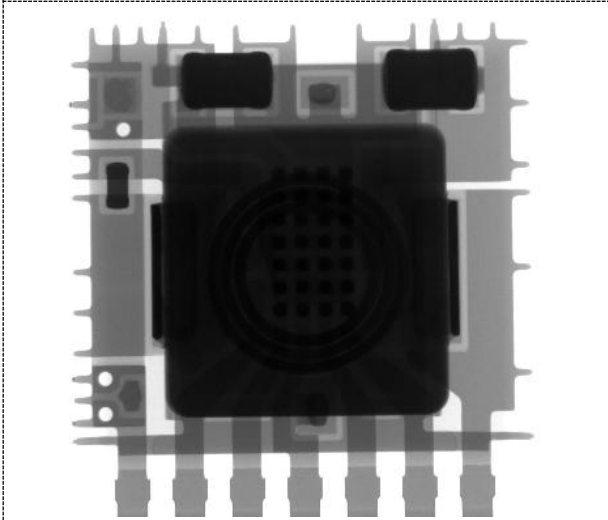

G1-Top View-Zoom-1

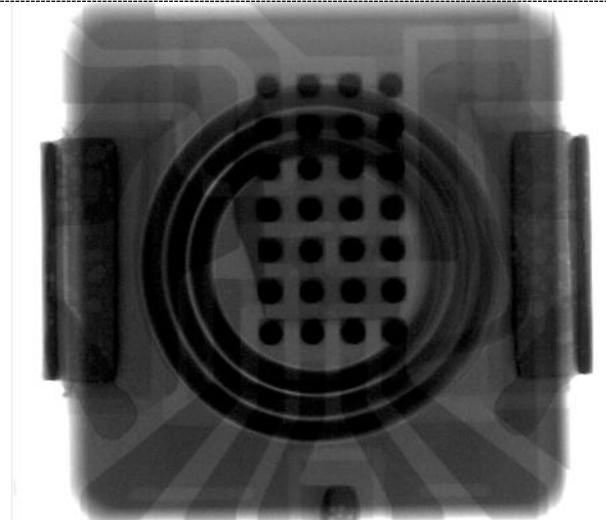

G1-Top View-Zoom-2(The area indicated by the arrow may have a silver glue anomaly)

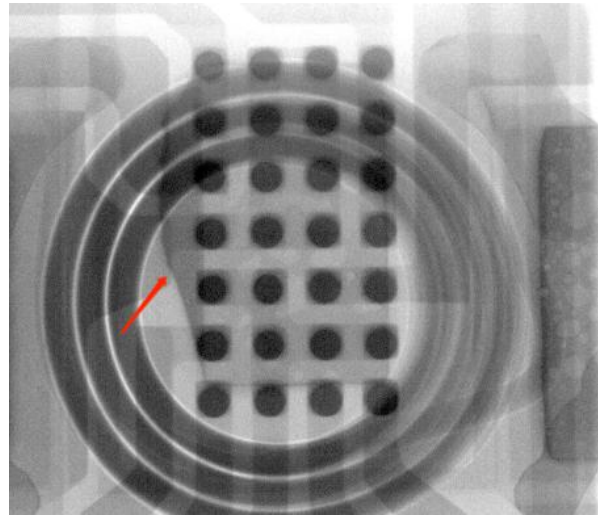

G1-Top View-Zoom-3(The selection in red box is welding cavity) voidage-29.987%

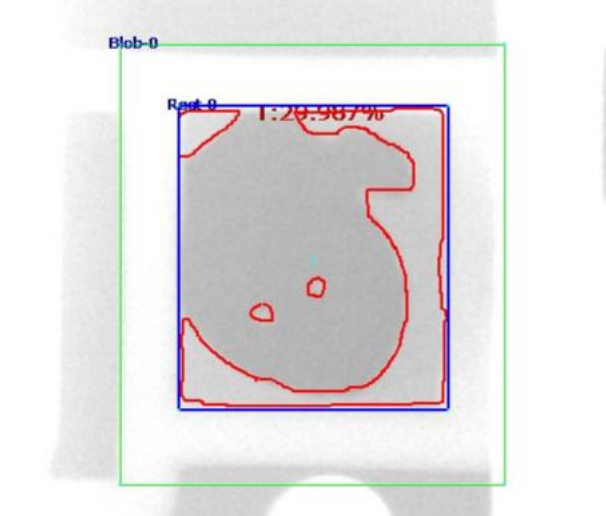

G2-Top View-All

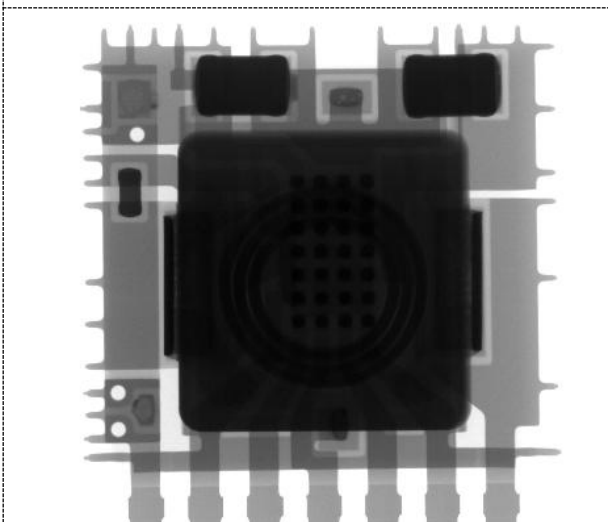

G2-Top View-Zoom-1

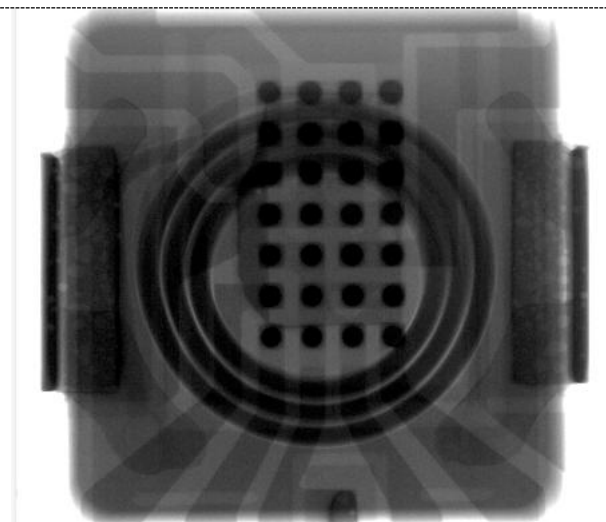



Chuangxin Online Test Center Laboratory

Add: F/r 401Building A, Ying Da Feng industrial No,393,Jihua Rd.LongGang
Dis. Shenzhen China
Tel: 0755-83765367 Email: taow@iclab-cn.com



Report No:	SZ07282021001
Date:	2021/07/28
Page:	8/10

G2-Top View-Zoom-2(The area indicated by the arrow may have a silver glue anomaly)

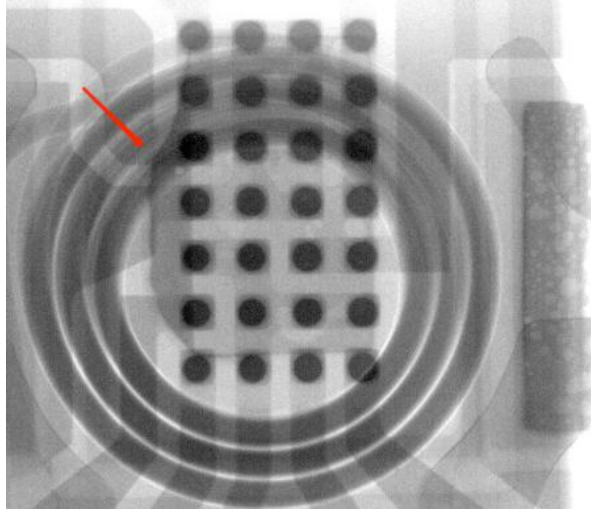

G2-Top View-Zoom-3(The selection in red box is welding cavity) voidage-39.215%

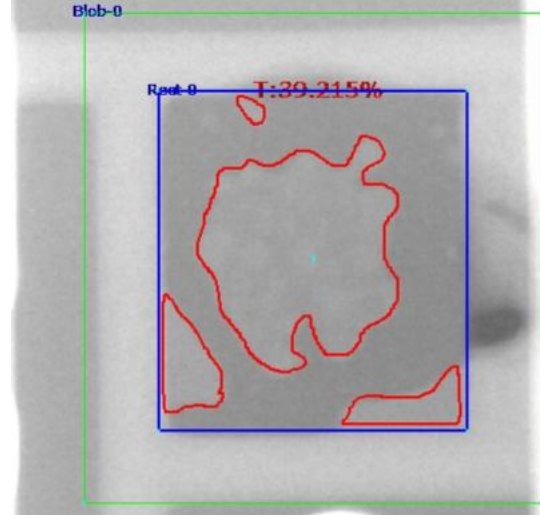

F1-Top View-All

F1-Top View-Zoom-1

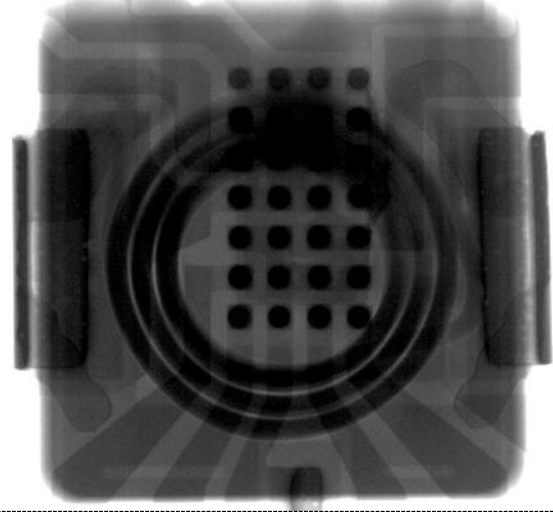
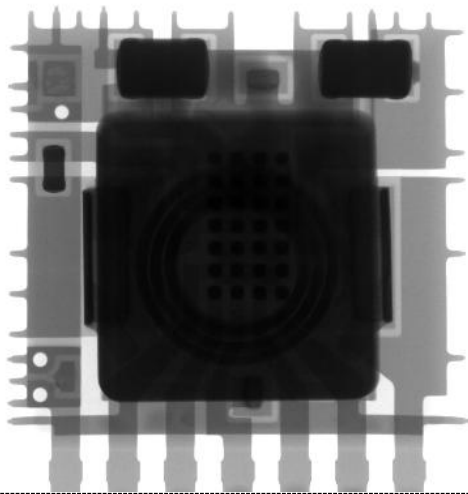

F1-Top View-Zoom-2(The area indicated by the arrow may have a silver glue anomaly)

F1-Top View-Zoom-3(The selection in red box is welding cavity) voidage-34.242%

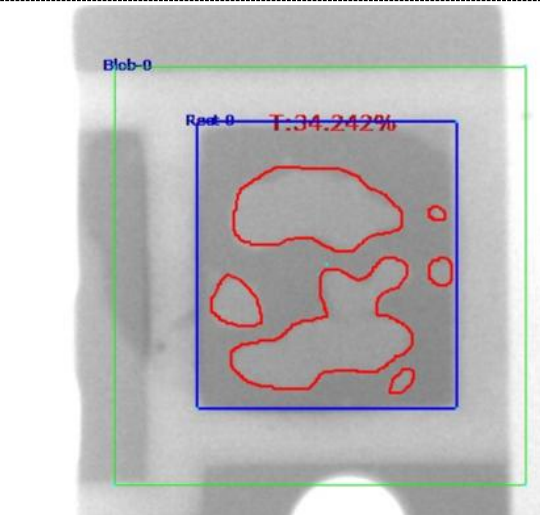
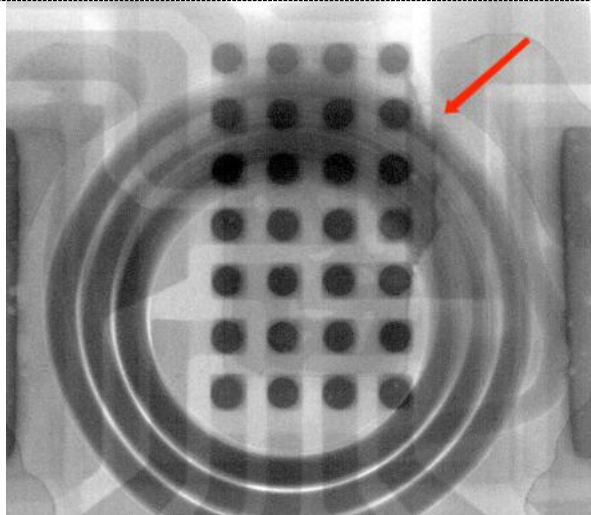



Chuangxin Online Test Center Laboratory

Add: F/r 401Building A, Ying Da Feng industrial No,393,Jihua Rd.LongGang
Dis. Shenzhen China
Tel: 0755-83765367 Email: taow@iclab-cn.com



Report No:	SZ07282021001
Date:	2021/07/28
Page:	9/10

F2-Top View-All

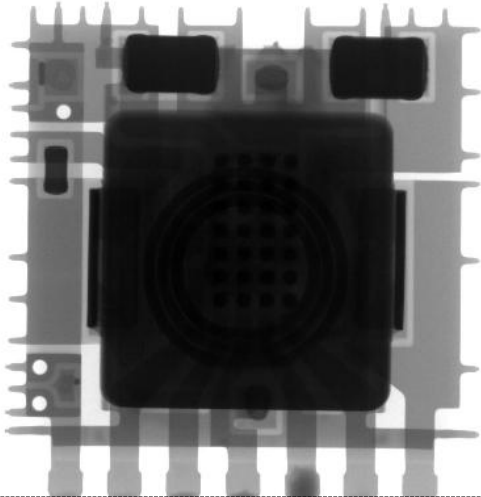

F2-Top View-Zoom-1(The area indicated by the arrow may have a silver glue anomaly)

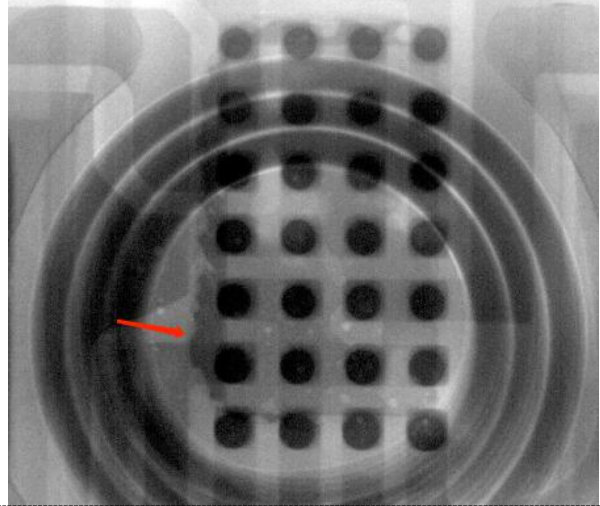

F2-Top View-Zoom-2(The selection in red box is welding cavity) voidage-39.197%

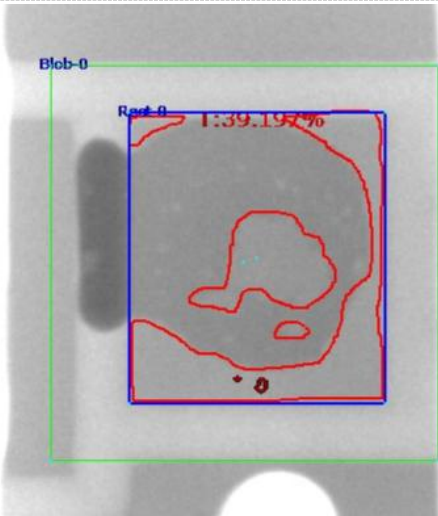

F2-Top View-Zoom-3(The red arrow indicates suspected adhesion)

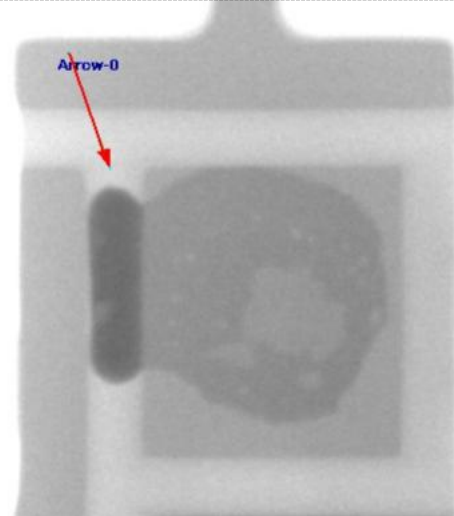

End



Chuangxin Online Test Center Laboratory

Add: F/r 401Building A, Ying Da Feng industrial No,393,Jihua Rd.LongGang
Dis. Shenzhen China
Tel: 0755-83765367 Email: taow@iclab-cn.com



Report No:	SZ07282021001
Date:	2021/07/28
Page:	10/10

For more information, please visit: <http://www.iclabcn.com>

CXO Lab WeChat official account

