

BQ24295

5V comes from wireless power receiver

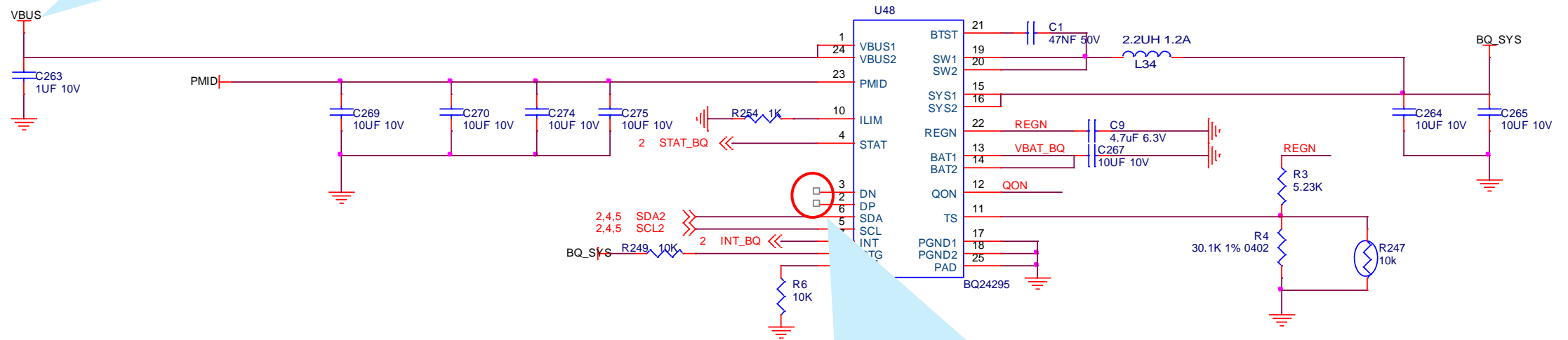

DN and DP are left open because there is no USB input

COIL
11.8uH

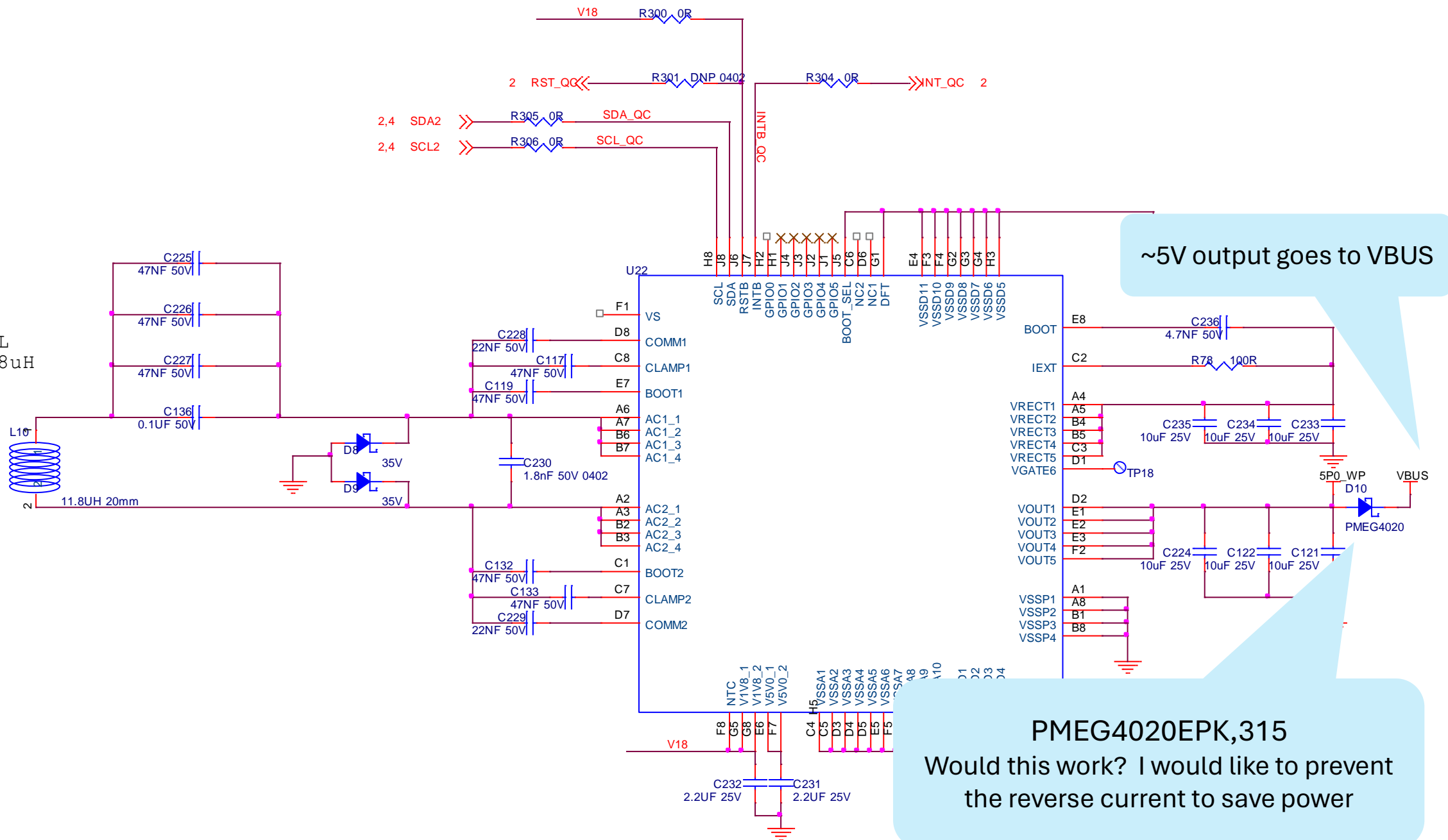

~5V output goes to VBUS

PMEG4020EPK,315
Would this work? I would like to prevent the reverse current to save power

Registers

- `reg_write_byte(0x00, 0x5a);`
 - 1A (100)
 - If we choose 500 mA (010), it doesn't seem to charge
 - ILIM is 1K
- `reg_write_byte(0x02, 0x1C);`
 - Charge Current 448 mA
 - The battery capacity is 320mA
- `reg_write_byte(0x05, 0x8c);`