

Micro Controller

0007968-01 Scribe power board Schematic
 0007969-01 Scribe power board ASSY
 0007970-01 Scribe power board PCB
 0007971-01 Scribe power board gerber

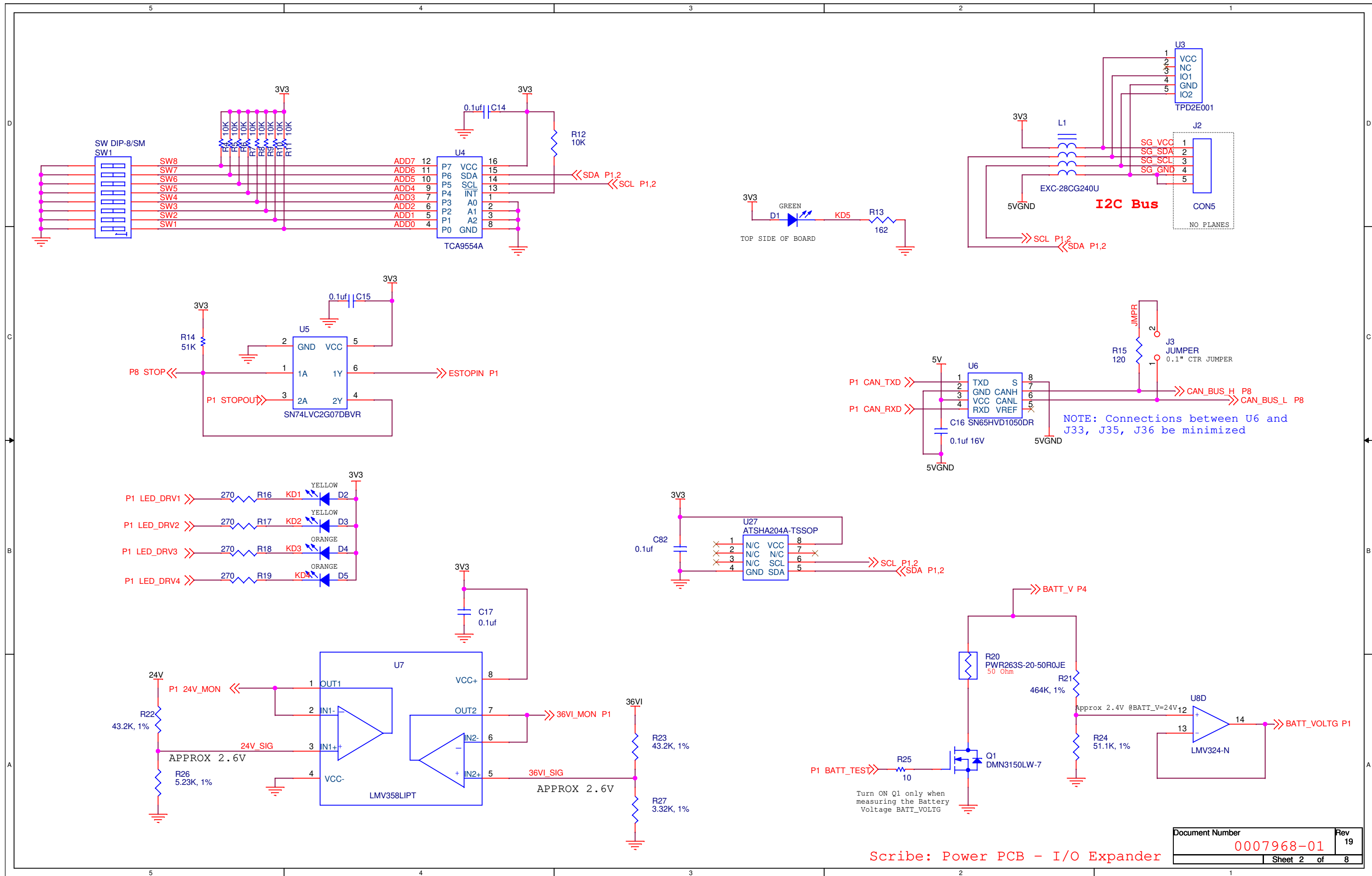

| | | |
|--------------|-------|--|
| DRAWN BY: AK | DATE: | PART DESCRIPTION |
| CHECKED BY: | DATE: | Scribe: Power PCB |
| APPROVED BY: | DATE: | DWG SIZE: B PART NUMBER: 0007968-01 REV: 19 SHEET of 8 |



Scribe: Power PCB - I/O Expander

| | | | |
|-----------------|------------|------------|----|
| Document Number | 0007968-01 | Rev | 19 |
| | | Sheet 2 of | 8 |

Min 20mil Traces: 24V,
MG_RT_OUT1,
MAG_RT_OUT2, MG_RT2,
MAG_RT1, MG_RT_RTN

LEFT MAG MOTOR
RIGHT MAG MOTOR

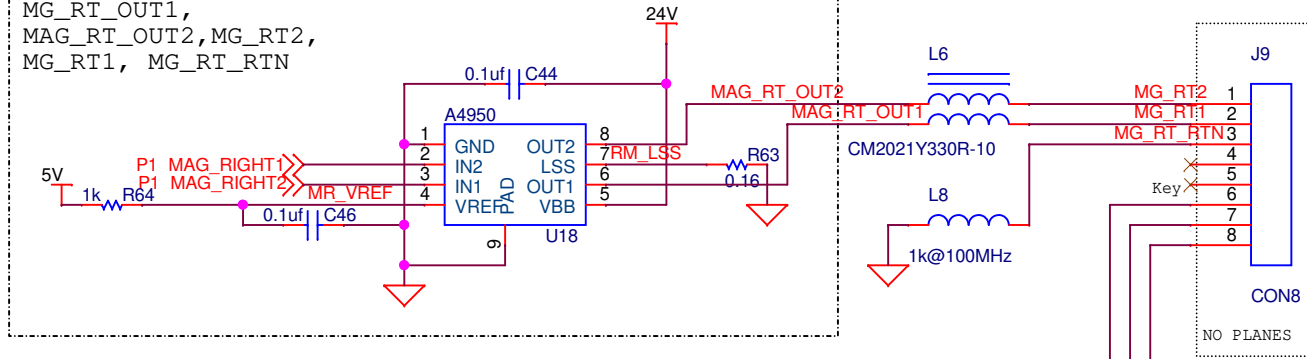

Min 20mil Traces: 24V,
MG_LF_OUT1,
MAG_LF_OUT2, MG_LF2,
MG_LF1, MG_LF_RTN

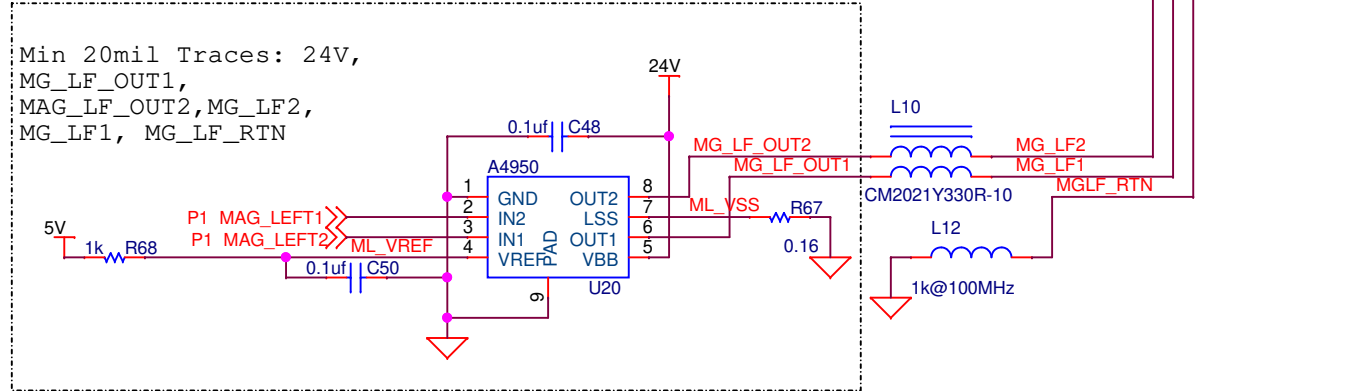

HEATER MOTOR

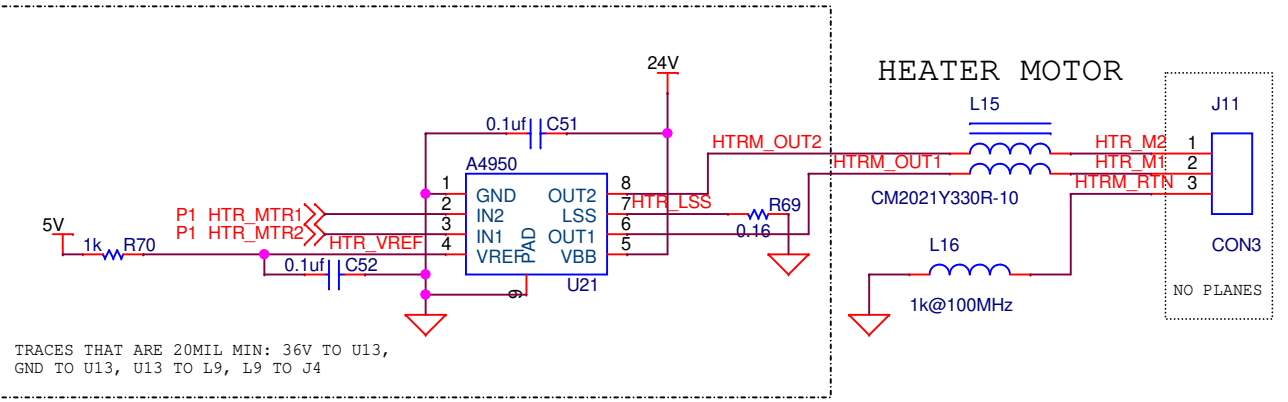

TRACES THAT ARE 20MIL MIN: 36V TO U13,
GND TO U13, U13 TO L9, L9 TO J4

EJECT KICKER MOTOR
REJECT TRAY MOTOR

Min 20mil Traces:
24V, EKKR_OUT2, EKKR_OUT1,
EKKR2, EKKR1, EKKR_RTN

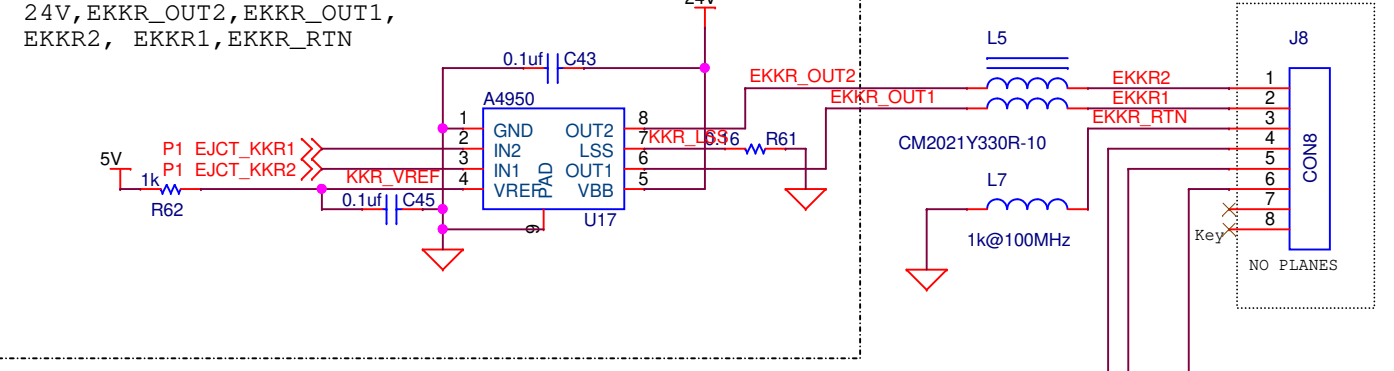

Min 20mil Traces: 24V,
RJCT_OUT1, RJCT_OUT2, RJCT2,
RJCT1, RJCT_RTN

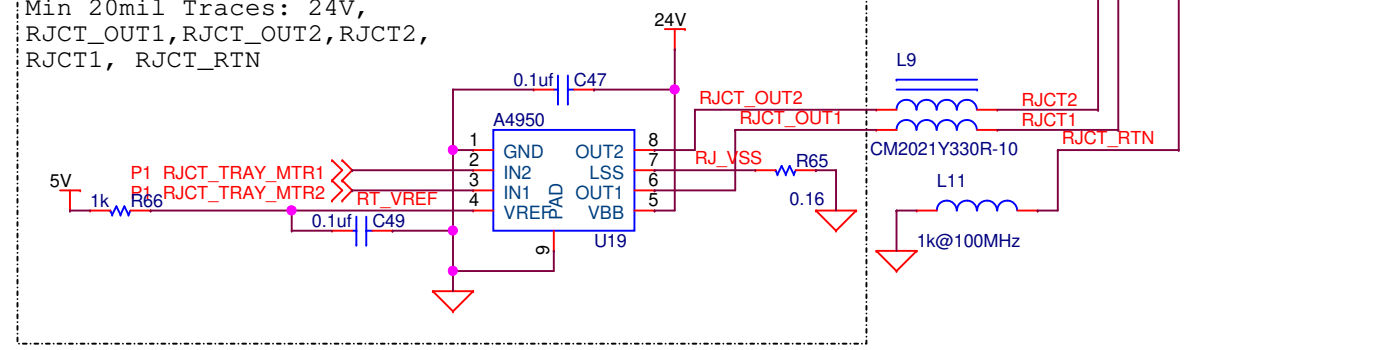

HEATER FAN

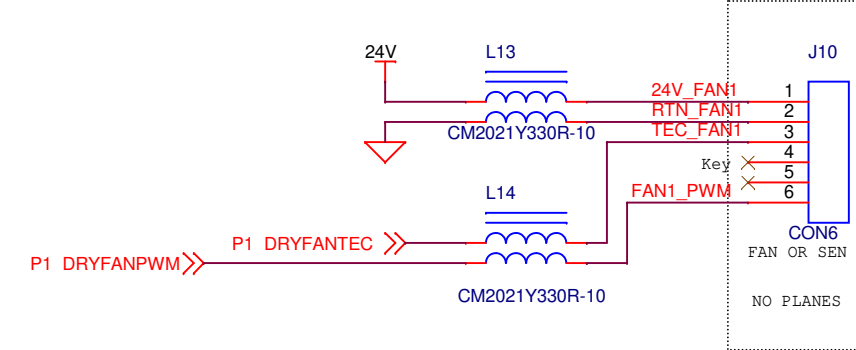

CASE CIRCULATION FAN

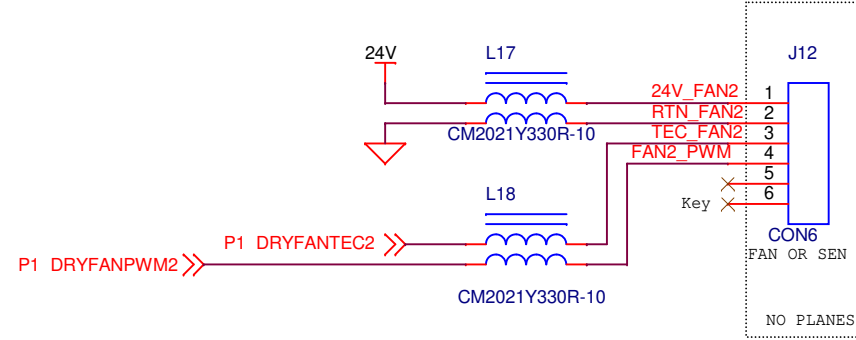

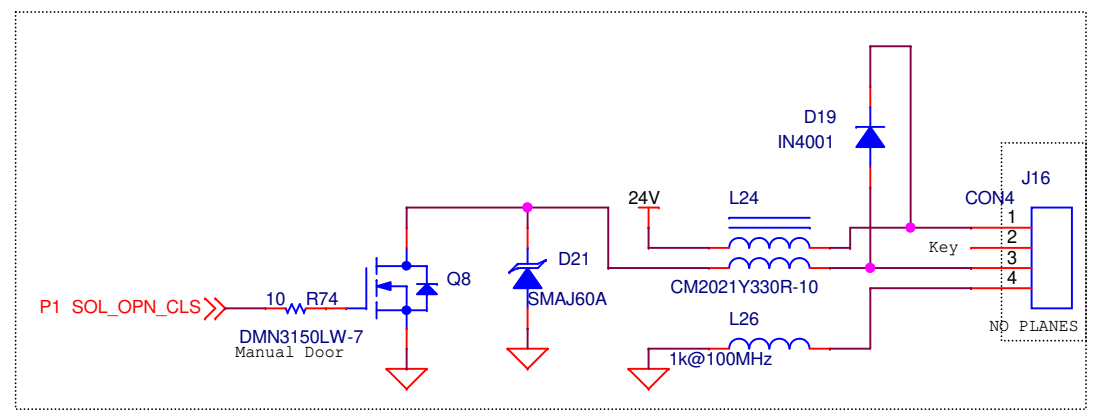
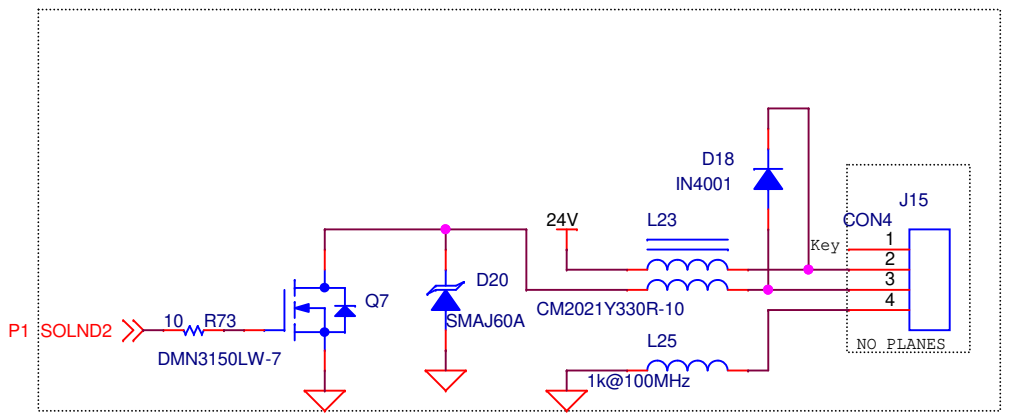
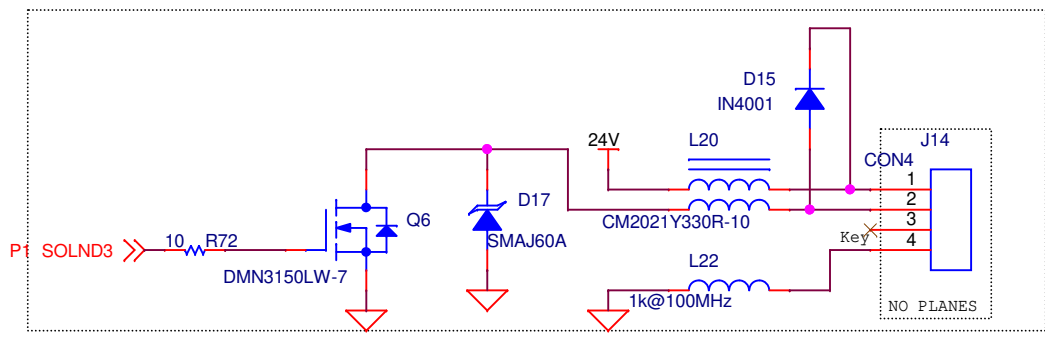
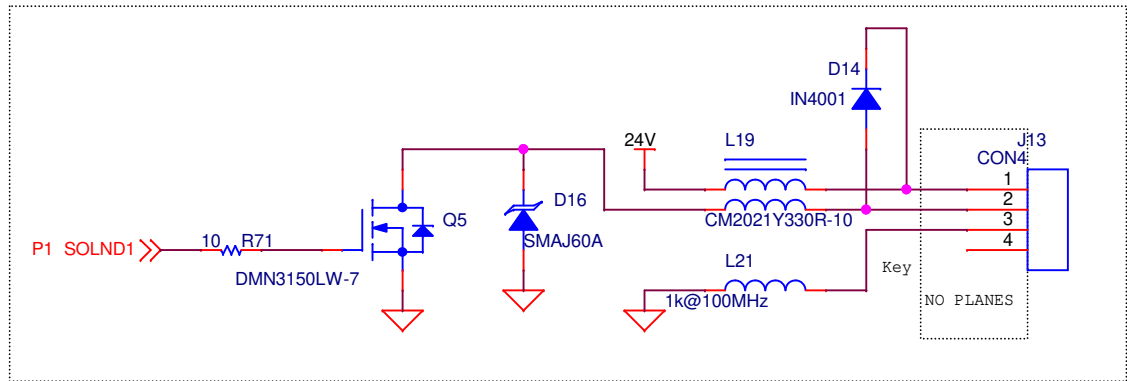

Scribe: Power PCB - Solenoid Drivers

| | | | |
|-----------------|------------|-----|----|
| Document Number | 0007968-01 | Rev | 19 |
| | Sheet 6 | of | 8 |

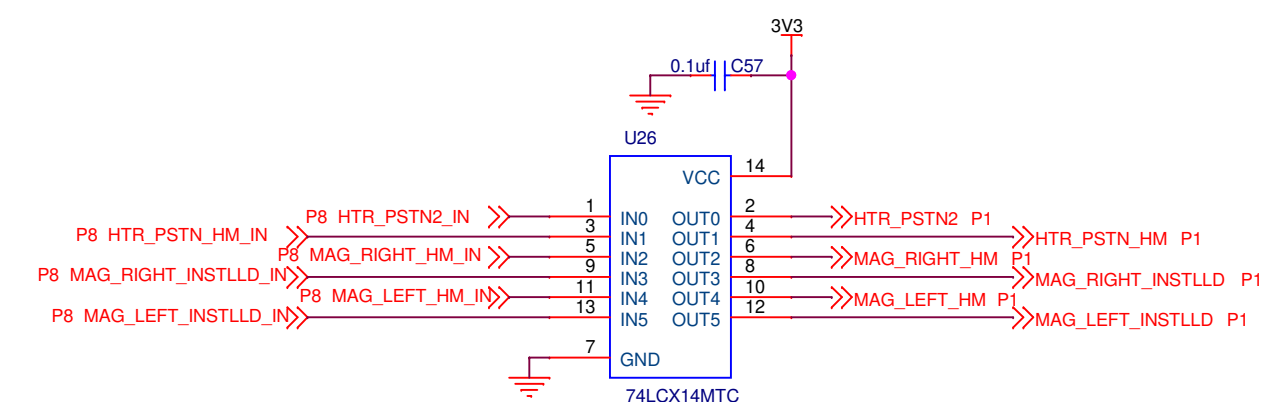
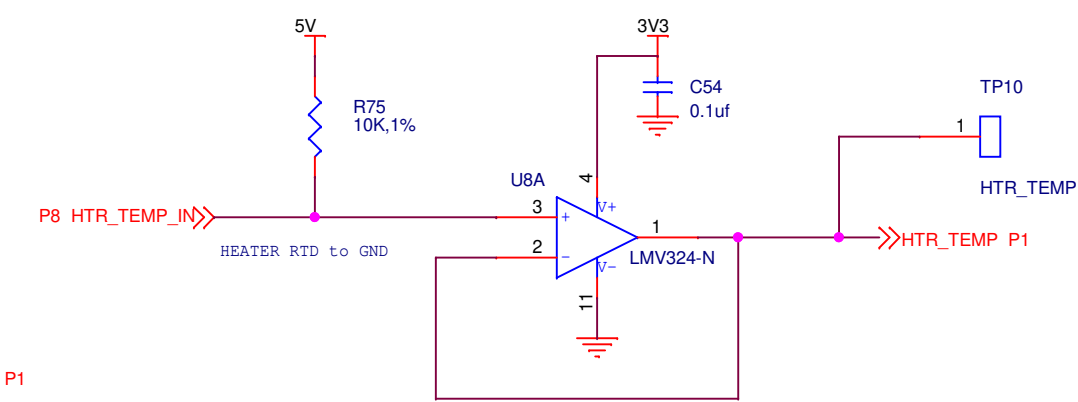
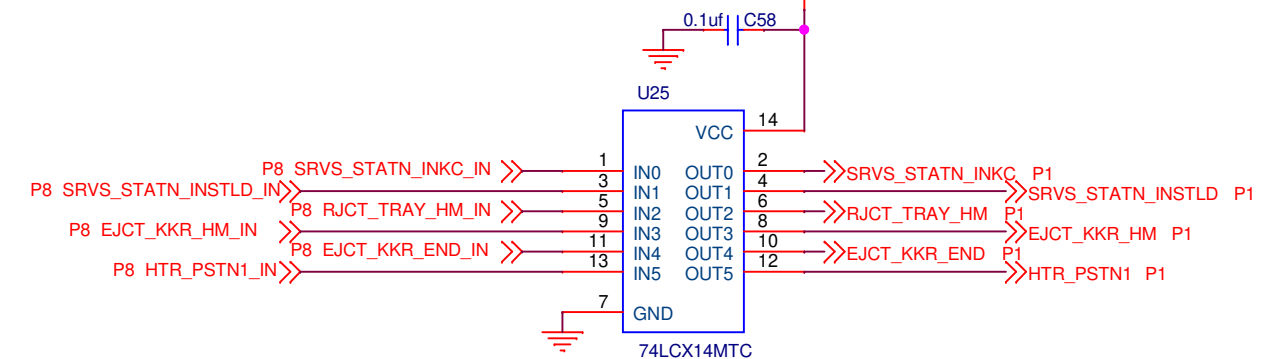
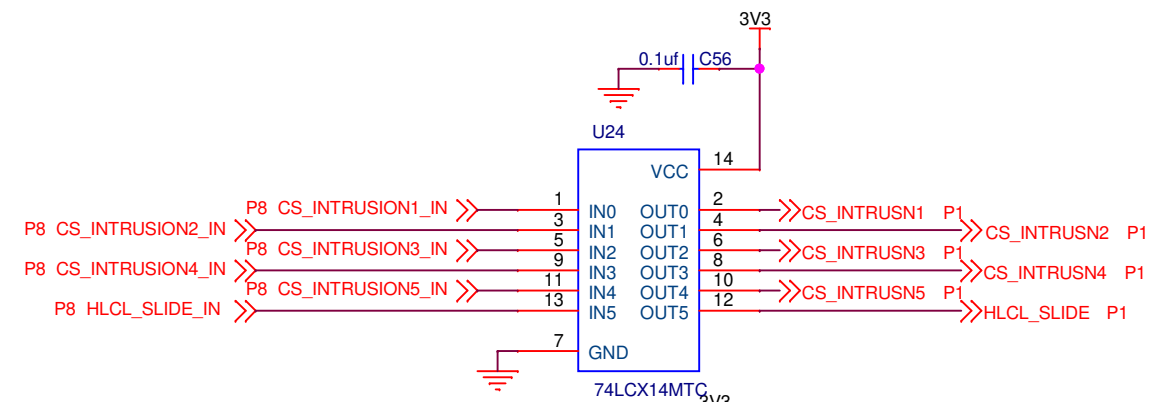
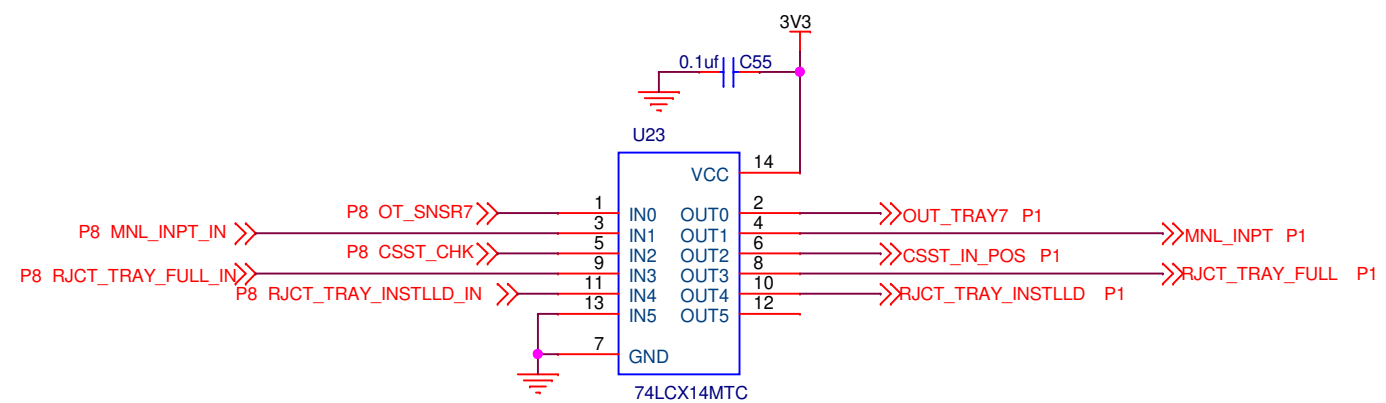
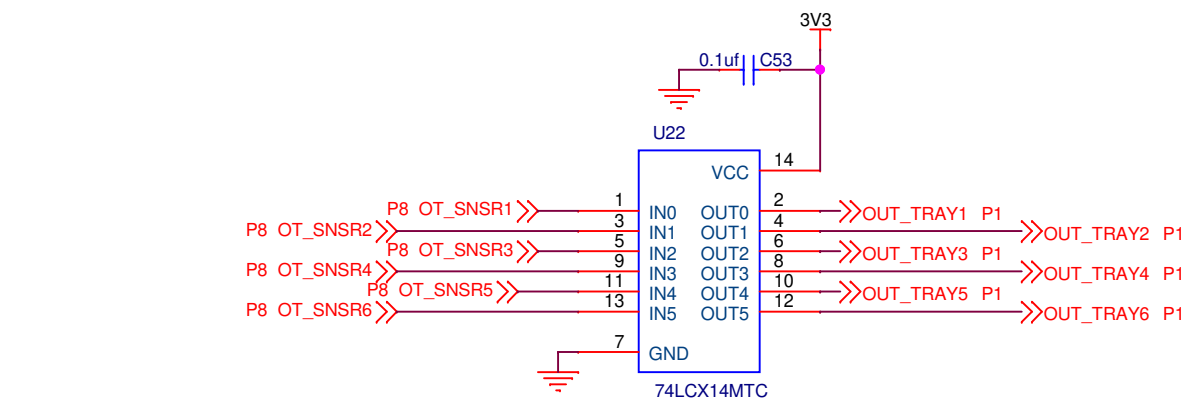

Scribe: Power PCB - Sensors

Sensors: U-Shaped Micro Photoelectric Sensors (PM-R25)

Sensors: Reflective Optical Sensor (OPB900)

| | | | |
|-----------------|------------|-----|----|
| Document Number | 0007968-01 | Rev | 19 |
| Sheet 7 of | | 8 | |

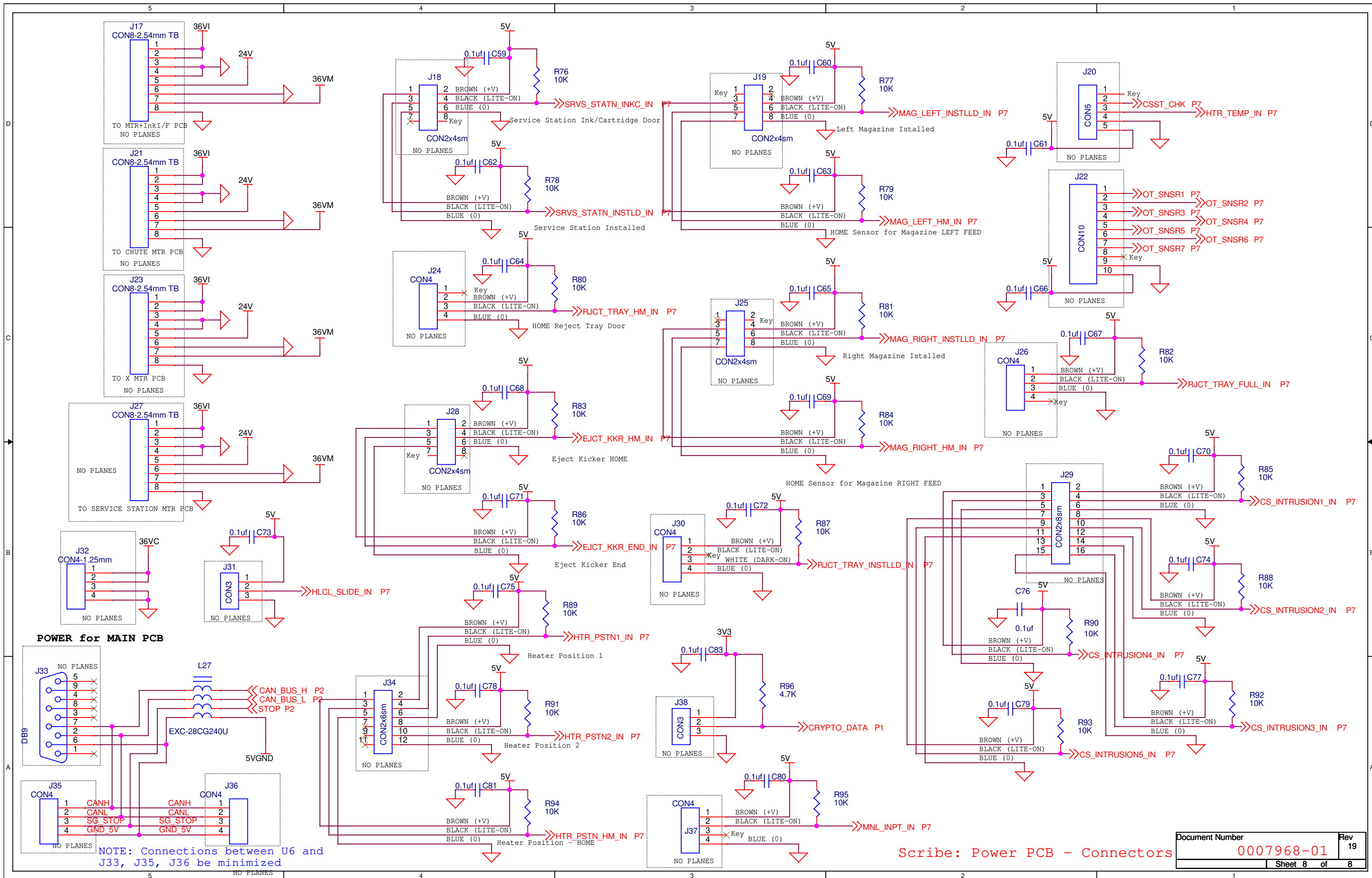

NOTE: Connections between U6 and J33, J35, J36 be minimized

Scribe: Power PCB - Connectors

| | | | |
|-----------------|------------|-------|--------|
| Document Number | 0007968-01 | Rev | 19 |
| | | Sheet | 8 of 8 |