

Battery Charger and Power path Management

Place decoupling caps as close to IC as possible

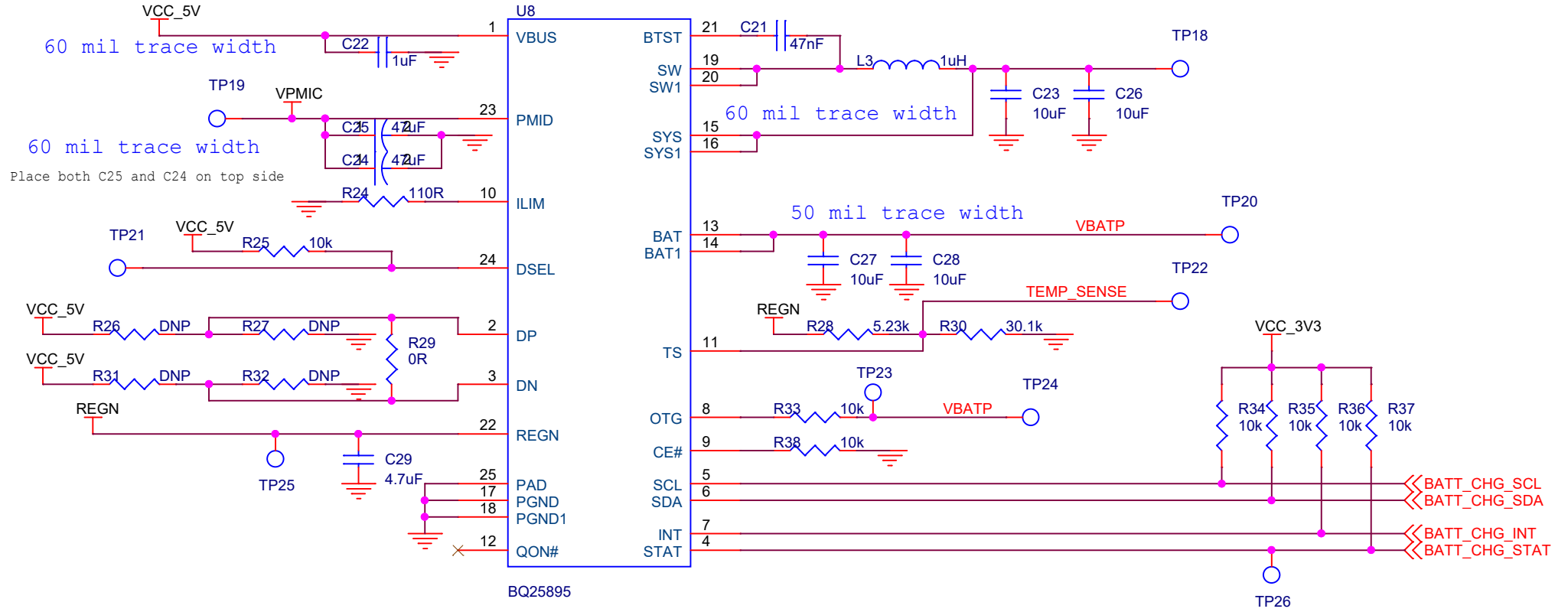

Battery, Thermistor, TV Tamper Switch Connector

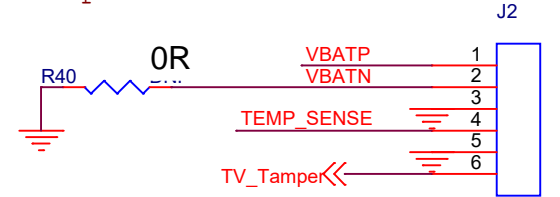

Use NTC 10k Semitech Thermistor Part # 103AT-2