

USB type c con internal(TPS65994 + TUSB1146)

USB type c mux
 USB3.0: USB32_1_TX_DP
 USB2.0: USB2_P1_DP
 DP: DDIB_TXP0
 DDIB_AUXP

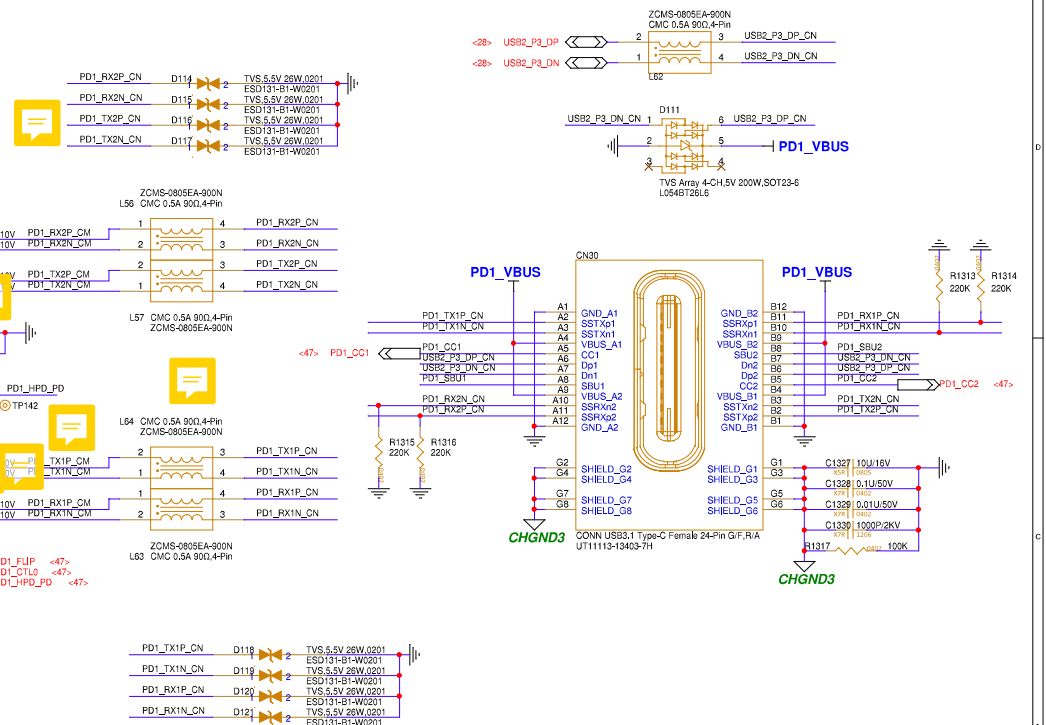
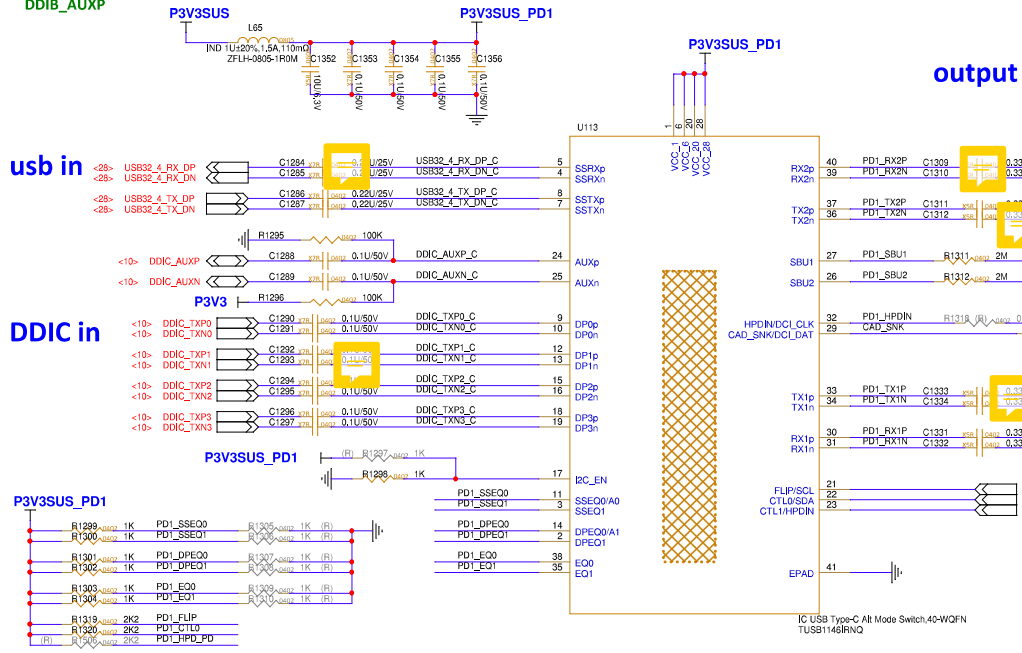

USB type c con internal(TPS65994 + TUSB1146)

USB type c mux
 USB3.0: USB32_5_TX_DP
 USB2.0: USB2_P1_DP
 DP: DDIB_TXP0
 DDIB_AUXP

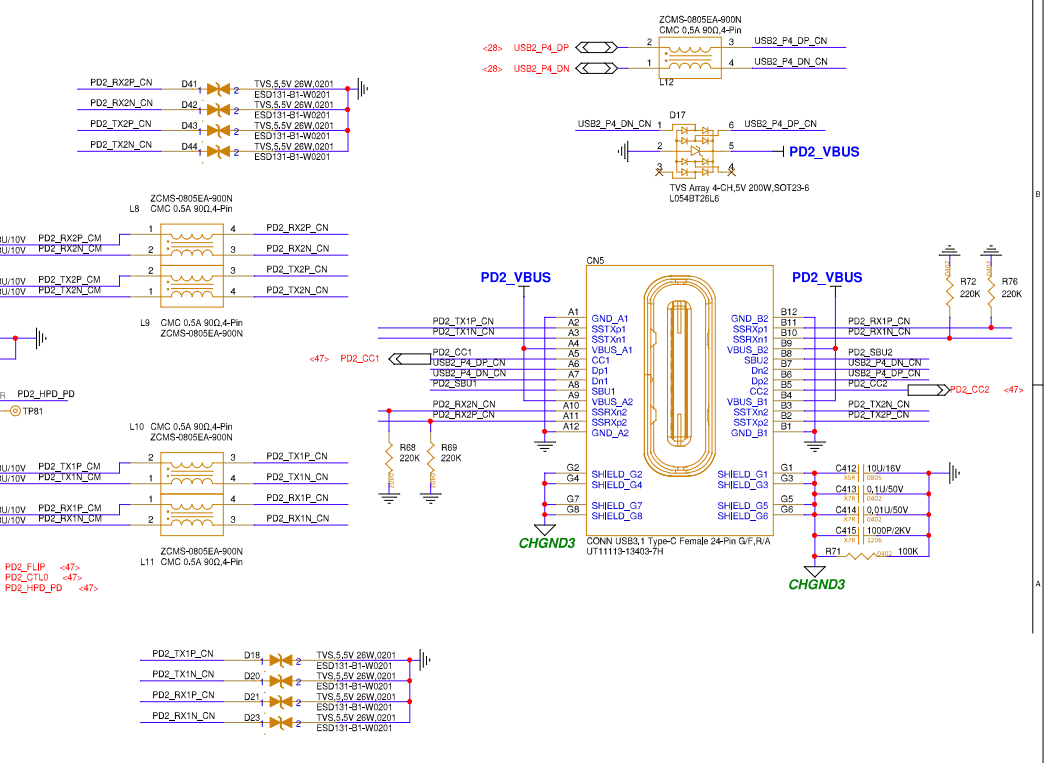
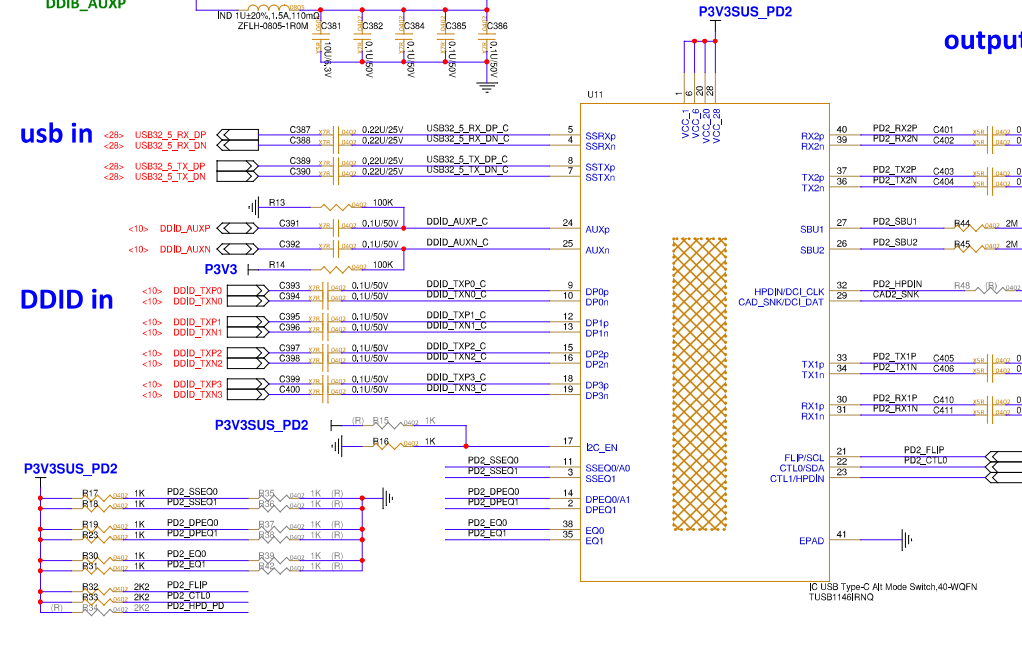

GPIO0: HPD_B
 GPIO1: HPD_A
 GPIO2\3\9: GPIO
 GPIO4\5: GPIO\ADCIN
 GPIO6\7\8: GPIO

GPIO1: May be used as DisplayPort HPD signal for Port A
 output: cable orientation: flip
 output: usb3 event: ctl0
 output: dp mode select: ctt1

