

- PWM\_AH\_B >> PWM\_AH\_B 18
- PWM\_AL\_B >> PWM\_AL\_B 18
- PWM\_BH\_B >> PWM\_BH\_B 18
- PWM\_BL\_B >> PWM\_BL\_B 18
- PWM\_CH\_B >> PWM\_CH\_B 18
- PWM\_CL\_B >> PWM\_CL\_B 18

- MCU\_EN\_GATE\_B >> MCU\_EN\_GATE\_B 18
- OCP\_DC >> OCP\_DC 16,18
- OCP\_PUV >> OCP\_PUV 16,18

- GH\_A >> MOS\_H\_U 15
- SH\_A >> SH\_U 11,15
- GL\_A >> MOS\_L\_U 15

- GH\_B >> MOS\_H\_V 15
- SH\_B >> SH\_V 11,15
- GL\_B >> MOS\_L\_V 15

- GH\_C >> MOS\_H\_W 15
- SH\_C >> SH\_W 15
- GL\_C >> MOS\_L\_W 15

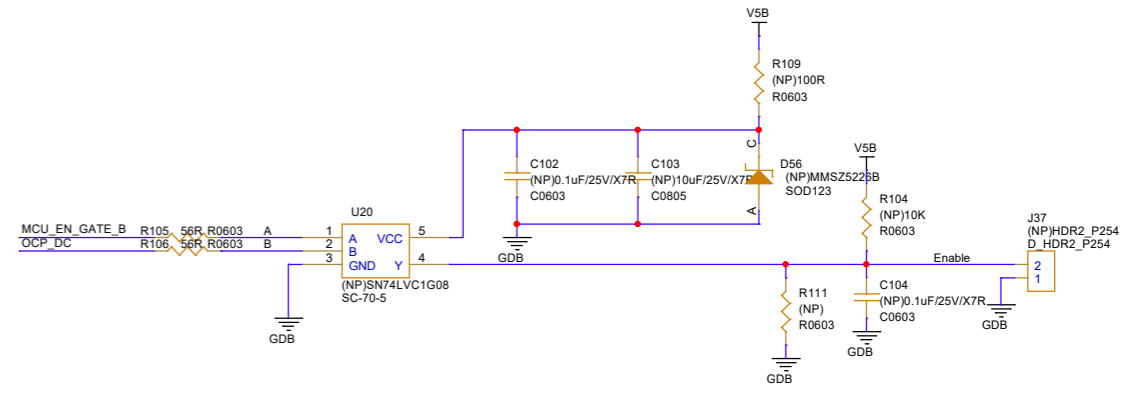
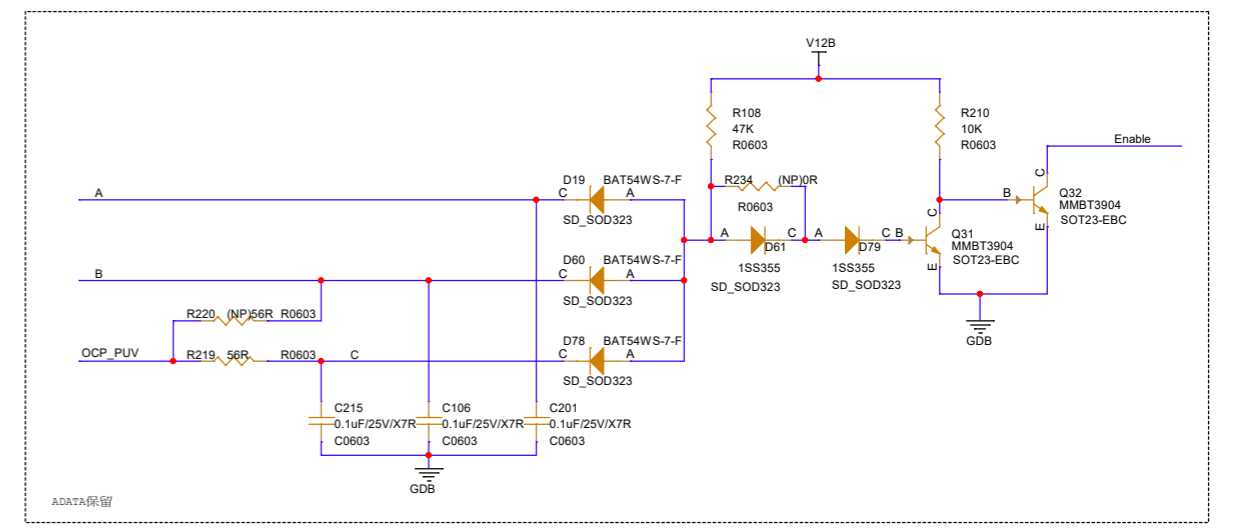
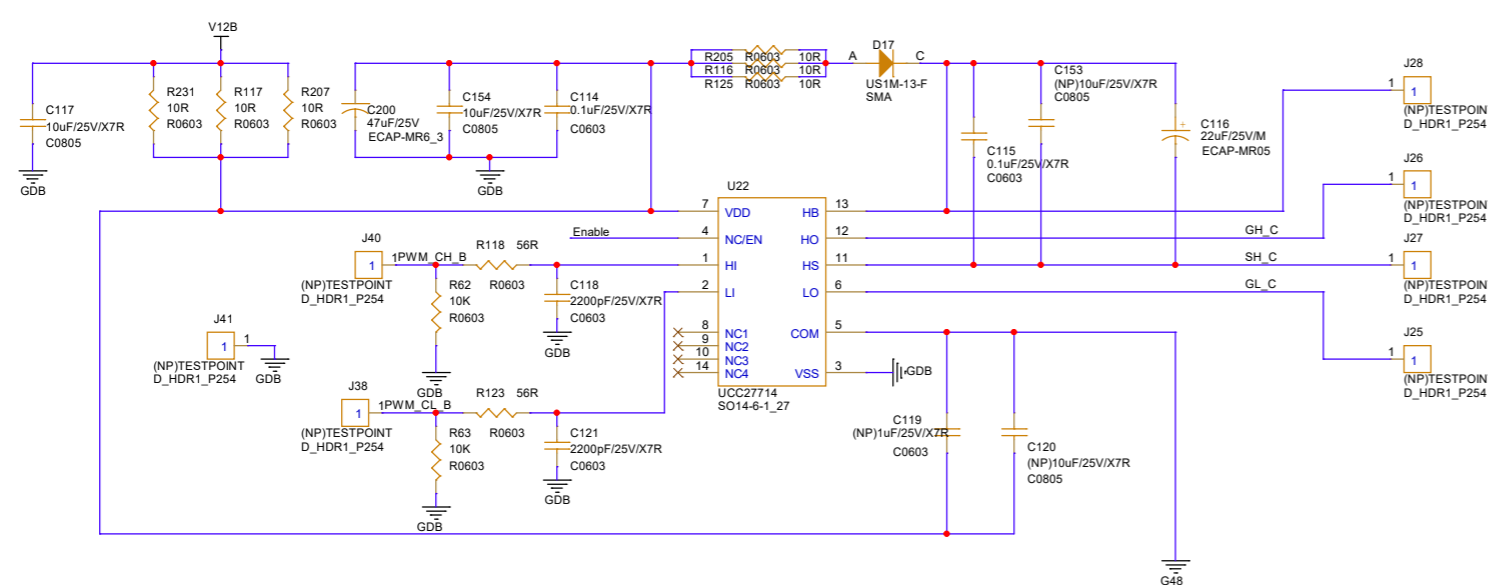
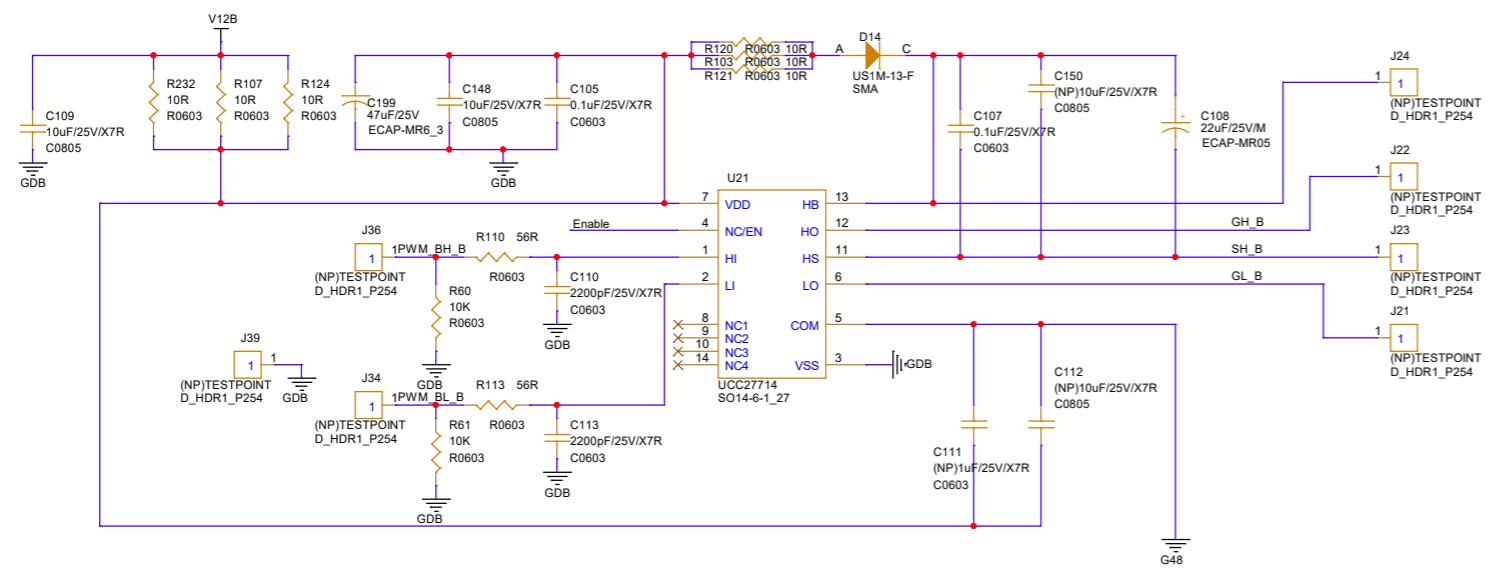



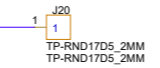
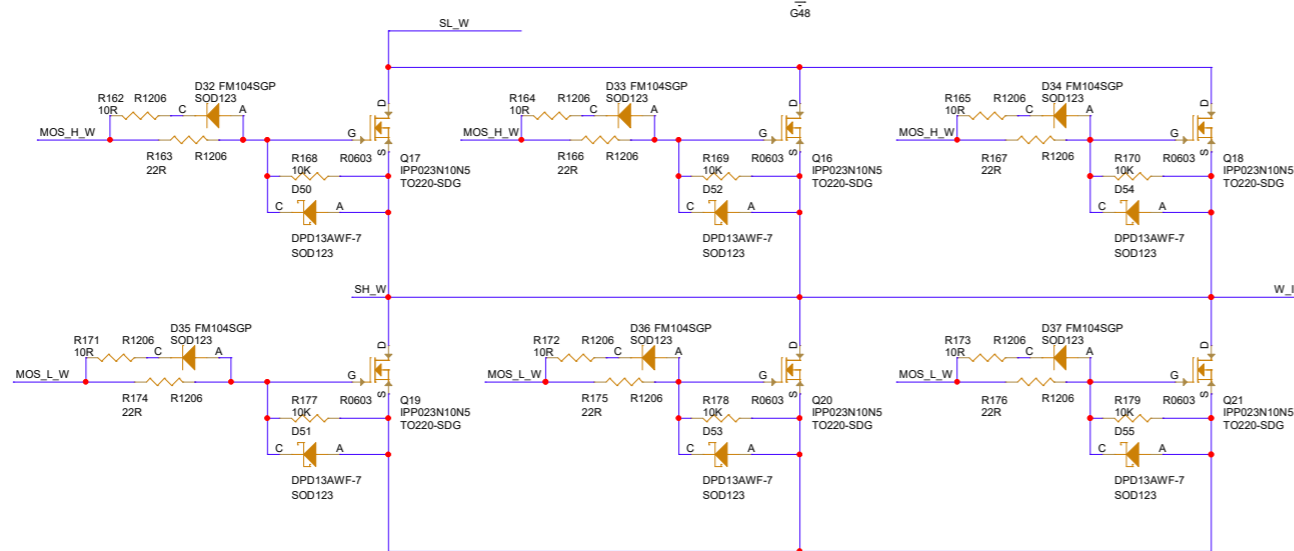
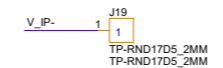
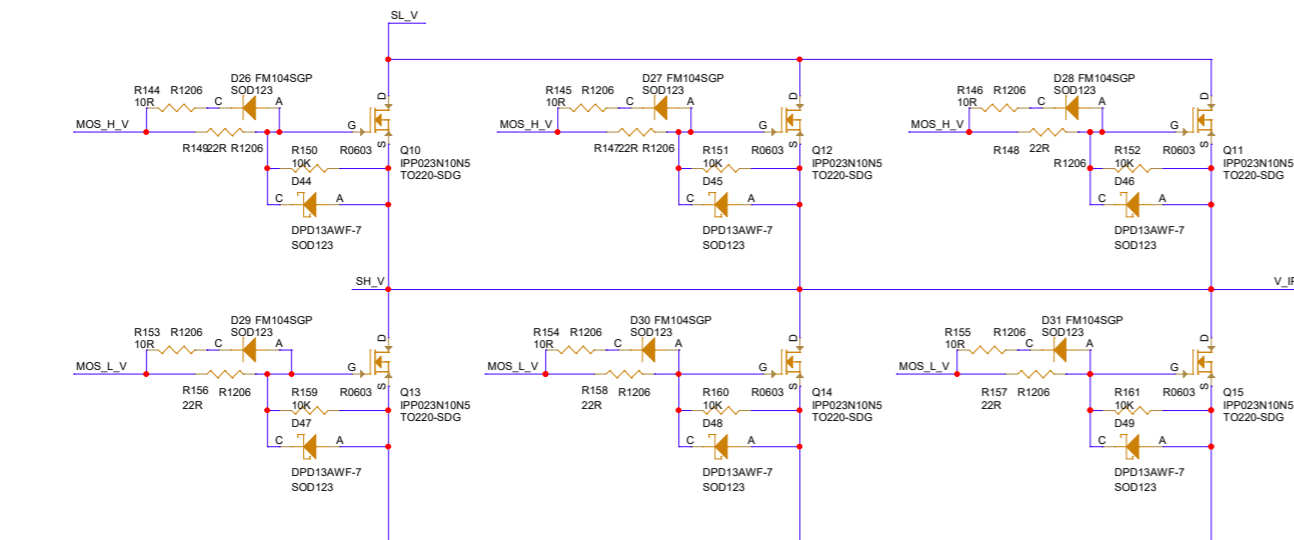
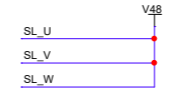
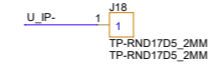
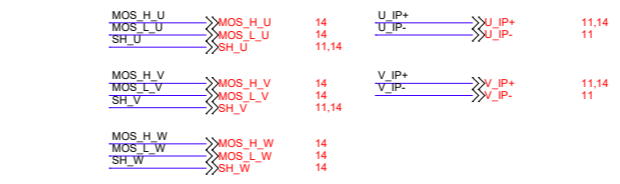
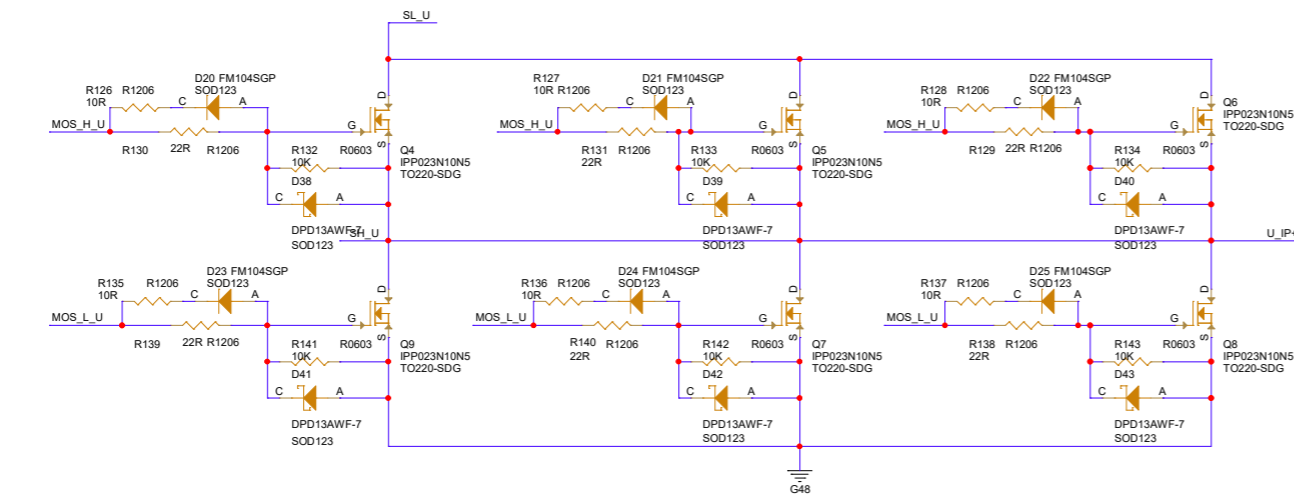

Title		
T128035		
Size	Document Number	Rev
C	MOS	0.7
Date:	Monday, July 02, 2018	Sheet 15 of 18