

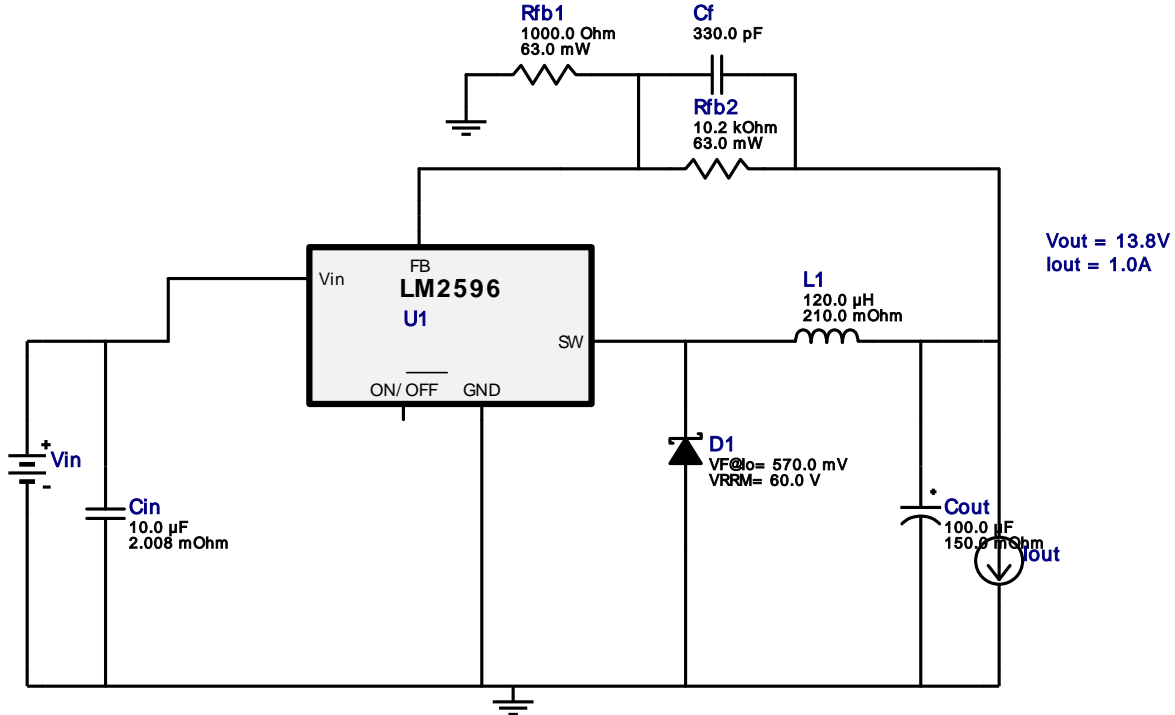





WEBENCH® Design Report

 Design : 433359/192 LM2596SX-ADJ/NOPB
 LM2596SX-ADJ/NOPB 16.0V-20.0V to 13.80V @ 1.0A

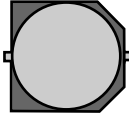
Electrical BOM

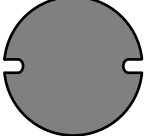
#	Name	Manufacturer	Part Number	Properties	Qty	Price	Footprint
1.	Cf	Samsung Electro-Mechanics	CL21C331JBANFNC Series= C0G/NP0	Cap= 330.0 pF VDC= 50.0 V IRMS= 0.0 A	1	\$0.01	 0805 7 mm ²
2.	Cin	MuRata	GRM32ER7YA106KA12L Series= X7R	Cap= 10.0 uF ESR= 2.008 mOhm VDC= 35.0 V IRMS= 4.6772 A	1	\$0.25	 1210_280 15 mm ²
3.	Cout	Panasonic	EEE-FC1V101P Series= FC	Cap= 100.0 uF ESR= 150.0 mOhm VDC= 35.0 V IRMS= 220.0 mA	1	\$0.24	 SM_RADIAL_G 172 mm ²
4.	D1	NXP Semiconductor	PMEG6010CEH,115	VF@Io= 570.0 mV VRRM= 60.0 V	1	\$0.04	 SOD-123F 12 mm ²
5.	L1	Bourns	SDR1307-121KL	L= 120.0 uH DCR= 210.0 mOhm	1	\$0.35	 SDR1307 227 mm ²
6.	Rfb1	Vishay-Dale	CRCW04021K00FKED Series= CRCW..e3	Res= 1000.0 Ohm Power= 63.0 mW Tolerance= 1.0%	1	\$0.01	 0402 3 mm ²

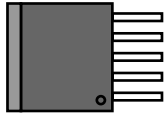
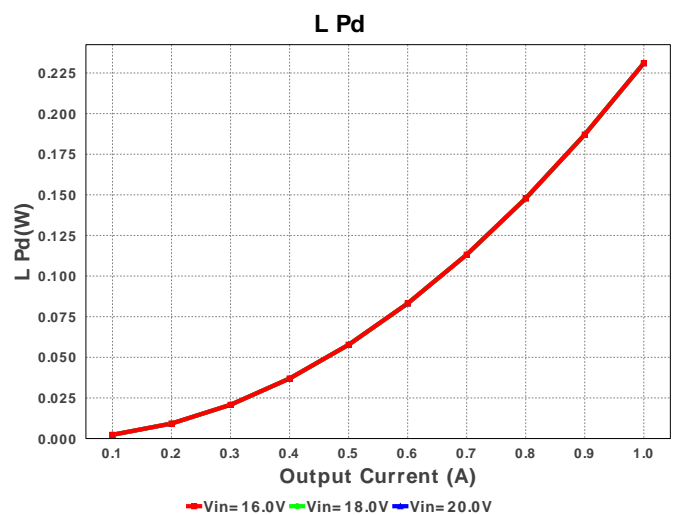
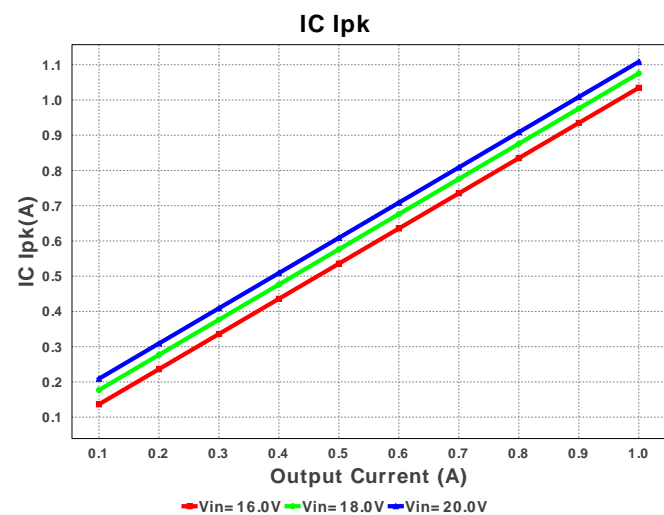
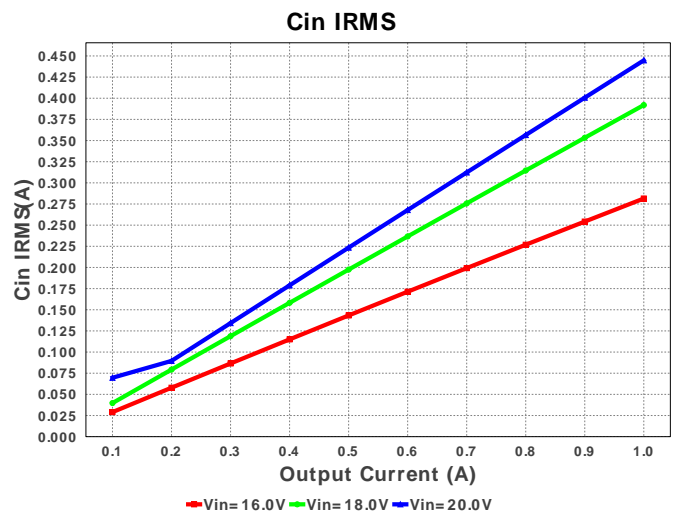
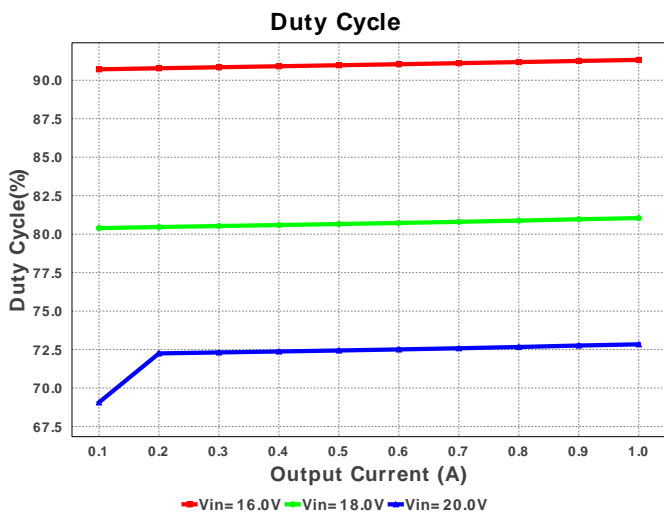
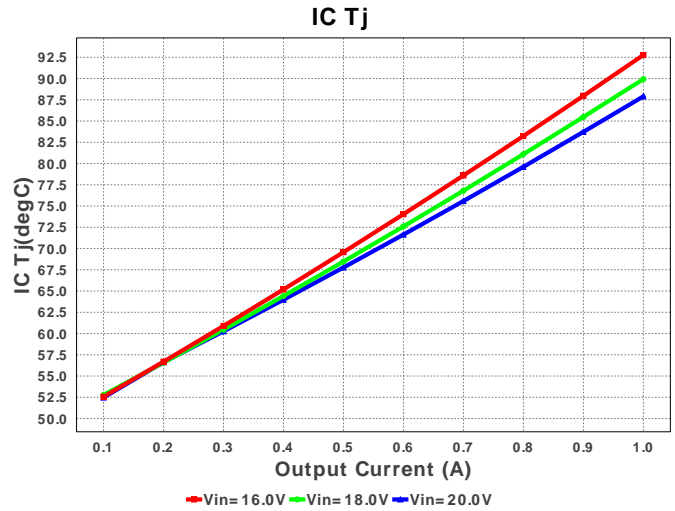
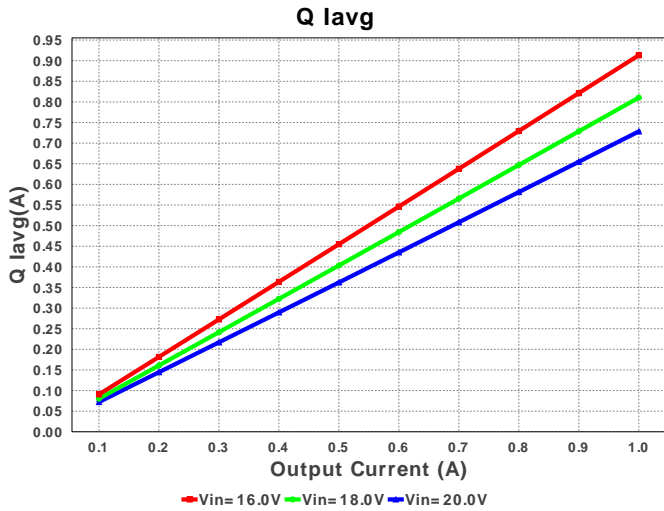
#	Name	Manufacturer	Part Number	Properties	Qty	Price	Footprint
7.	Rfb2	Vishay-Dale	CRCW040210K2FKED Series= CRCW..e3	Res= 10.2 kOhm Power= 63.0 mW Tolerance= 1.0%	1	\$0.01	0402 3 mm ²
8.	U1	Texas Instruments	LM2596SX-ADJ/NOPB	Switcher	1	\$1.80	 TS5B 199 mm ²

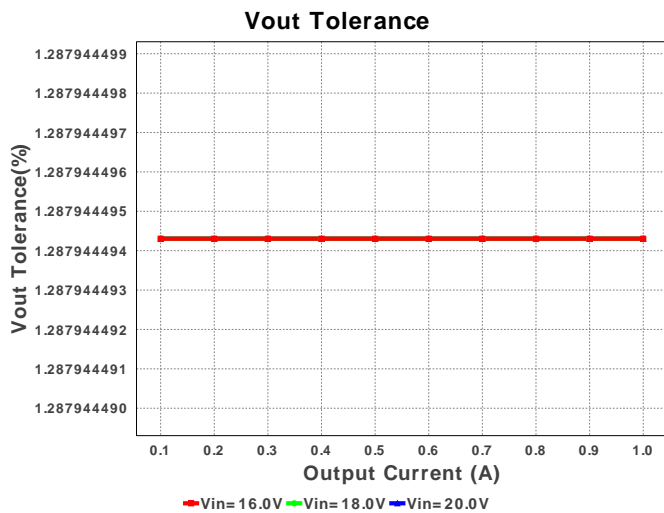
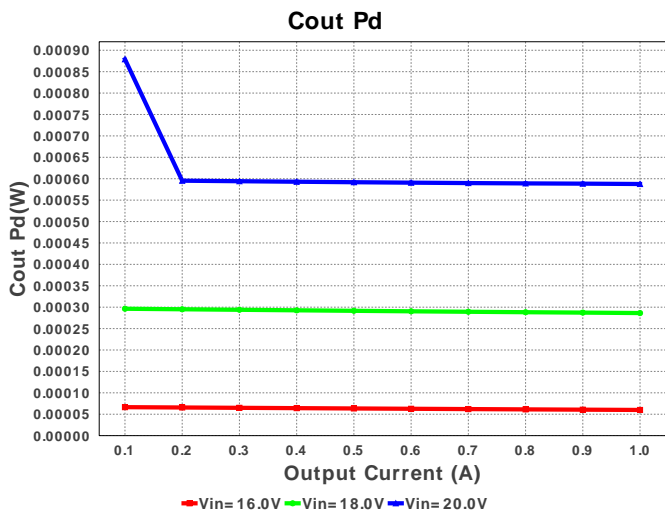
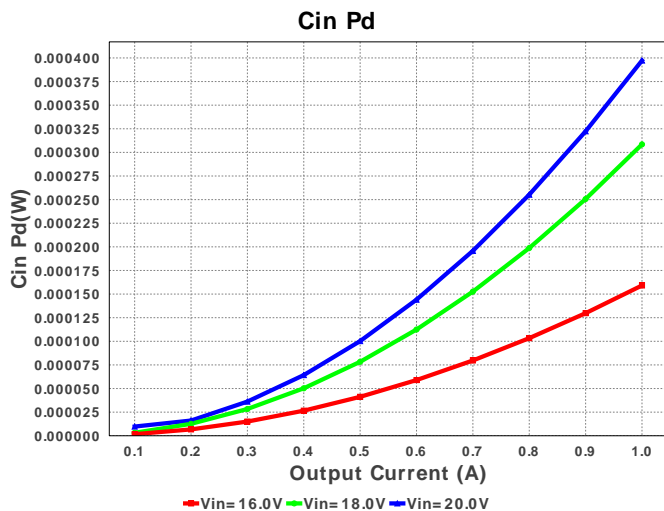
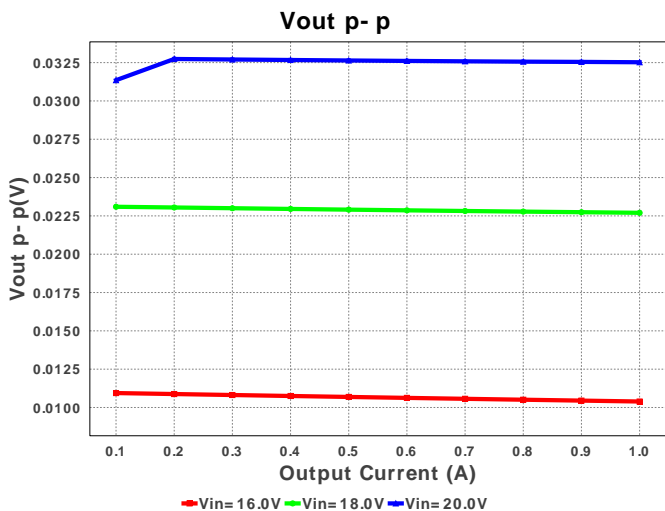
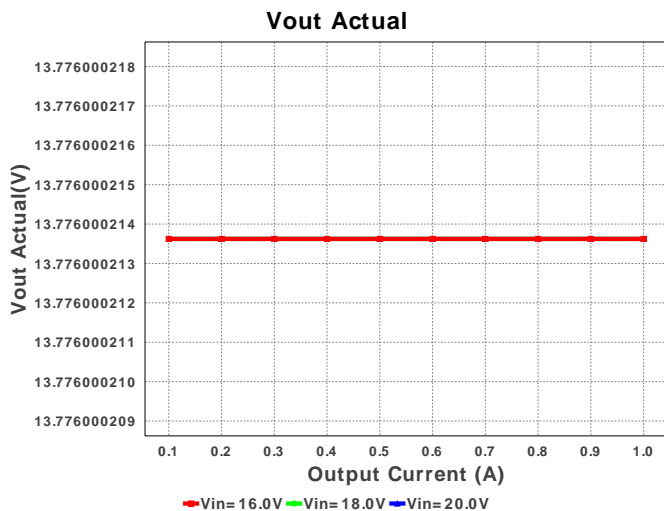
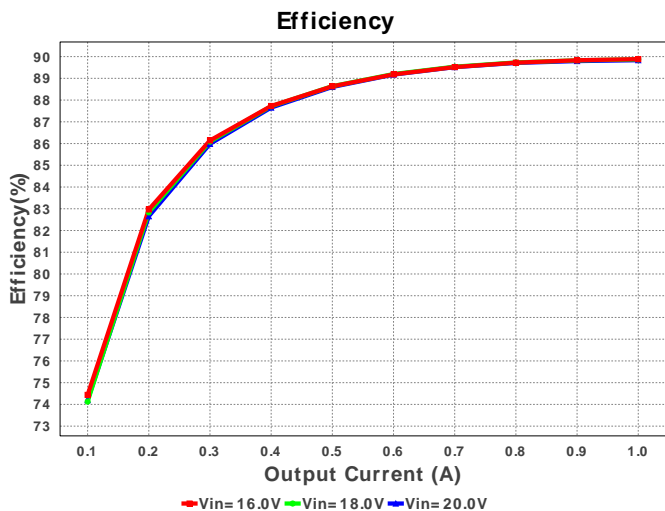

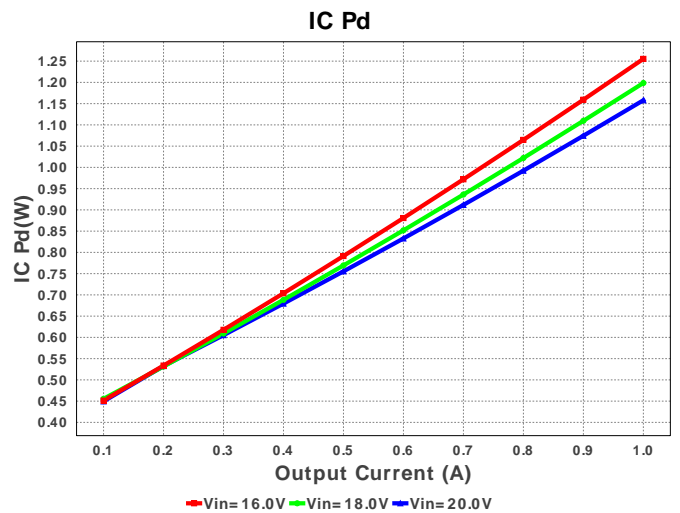
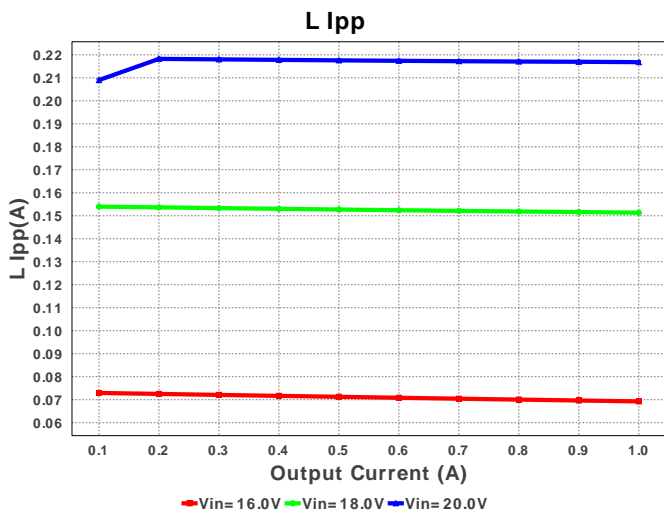
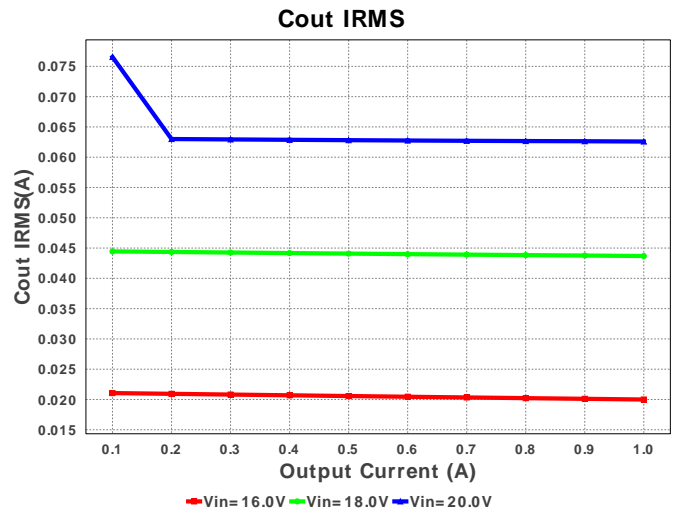
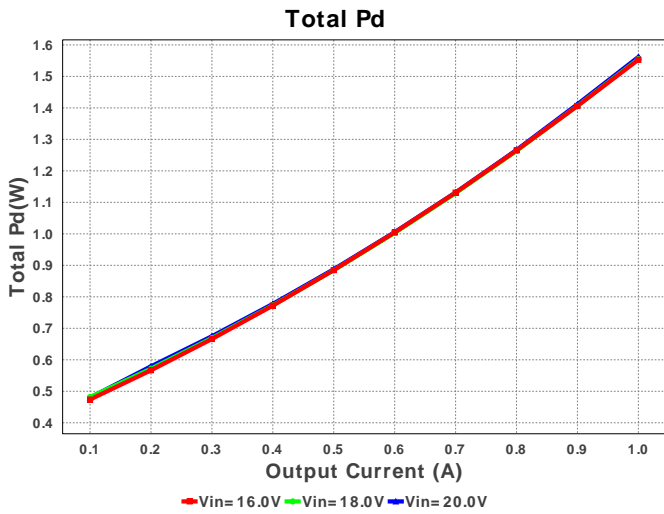
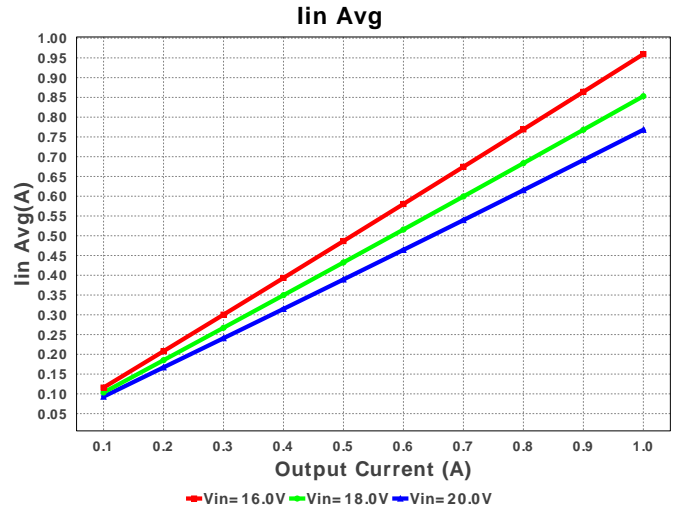
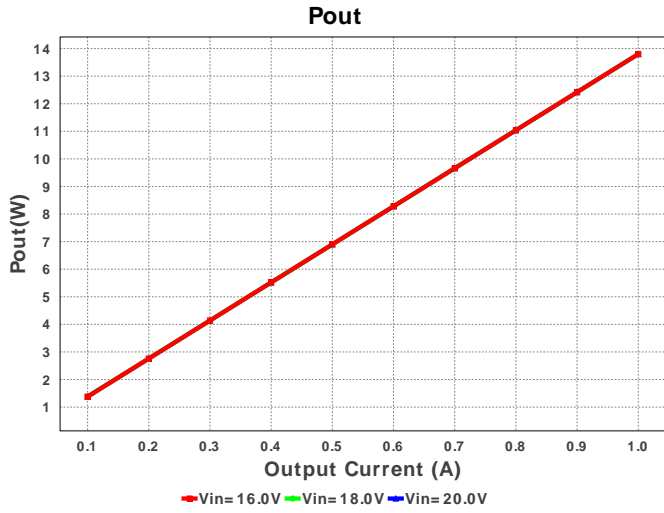



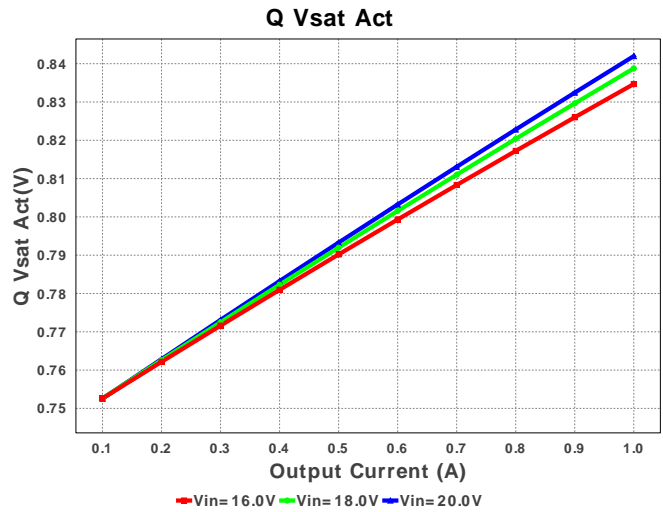
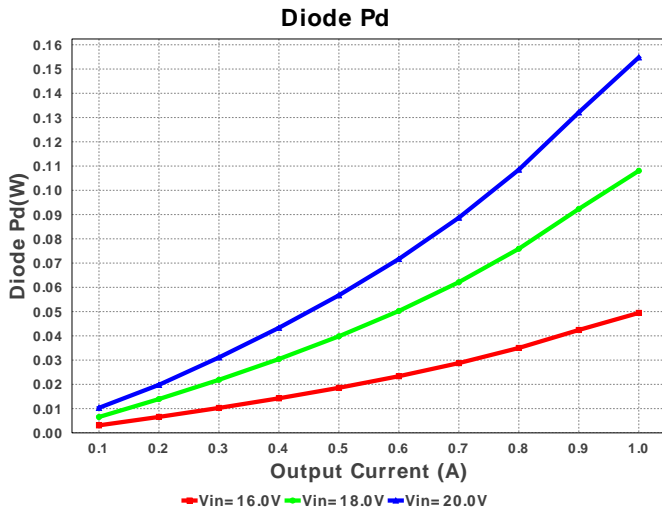

Operating Values

#	Name	Value	Category	Description
1.	Cin IRMS	444.782 mA	Current	Input capacitor RMS ripple current
2.	Cout IRMS	62.591 mA	Current	Output capacitor RMS ripple current
3.	IC Ipk	1.108 A	Current	Peak switch current in IC
4.	Iin Avg	768.09 mA	Current	Average input current
5.	L Ipp	216.82 mA	Current	Peak-to-peak inductor ripple current
6.	Q Iavg	728.406 mA	Current	Q Iavg
7.	BOM Count	8	General	Total Design BOM count
8.	FootPrint	637.0 mm ²	General	Total Foot Print Area of BOM components
9.	Frequency	150.0 kHz	General	Switching frequency
10.	IC Tolerance	0.0 V	General	IC Feedback Tolerance
11.	Pout	13.8 W	General	Total output power
12.	Q Vsat Act	841.98 mV	General	Q Vsat
13.	Total BOM	\$2.71	General	Total BOM Cost
14.	Vout Actual	13.776 V	Op_Point	Vout Actual calculated based on selected voltage divider resistors
15.	Cross Freq	13.183 kHz	Op_point	Bode plot crossover frequency
16.	Duty Cycle	72.841 %	Op_point	Duty cycle
17.	Efficiency	89.834 %	Op_point	Steady state efficiency
18.	IC Tj	87.896 degC	Op_point	IC junction temperature
19.	ICThetaJA	50.0 degC/W	Op_point	IC junction-to-ambient thermal resistance
20.	IOUT_OP	1.0 A	Op_point	Iout operating point
21.	Phase Marg	63.932 deg	Op_point	Bode Plot Phase Margin
22.	VIN_OP	20.0 V	Op_point	Vin operating point
23.	Vout p-p	32.523 mV	Op_point	Peak-to-peak output ripple voltage
24.	Cin Pd	397.244 μW	Power	Input capacitor power dissipation
25.	Cout Pd	587.652 μW	Power	Output capacitor power dissipation
26.	Diode Pd	154.809 mW	Power	Diode power dissipation
27.	IC Pd	1.158 W	Power	IC power dissipation
28.	L Pd	231.0 mW	Power	Inductor power dissipation
29.	Total Pd	1.562 W	Power	Total Power Dissipation
30.	Vout Tolerance	1.288 %		Vout Tolerance based on IC Tolerance and voltage divider resistors if applicable

Design Inputs

#	Name	Value	Description
1.	Iout	1.0	Maximum Output Current
2.	VinMax	20.0	Maximum input voltage
3.	VinMin	16.0	Minimum input voltage
4.	Vout	13.8	Output Voltage
5.	base_pn	LM2596	Base Product Number
6.	source	DC	Input Source Type
7.	Ta	30.0	Ambient temperature

Design Assistance

1. **LM2596** Product Folder : <http://www.ti.com/product/LM2596> : contains the data sheet and other resources.

Texas Instruments' WEBENCH simulation tools attempt to recreate the performance of a substantially equivalent physical implementation of the design. Simulations are created using Texas Instruments' published specifications as well as the published specifications of other device manufacturers. While Texas Instruments does update this information periodically, this information may not be current at the time the simulation is built. Texas Instruments does not warrant the accuracy or completeness of the specifications or any information contained therein. Texas Instruments does not warrant that any designs or recommended parts will meet the specifications you entered, will be suitable for your application or fit for any particular purpose, or will operate as shown in the simulation in a physical implementation. Texas Instruments does not warrant that the designs are production worthy.

You should completely validate and test your design implementation to confirm the system functionality for your application prior to production.

Use of Texas Instruments' WEBENCH simulation tools is subject to [Texas Instruments' Site Terms and Conditions of Use](#). Prototype boards based on WEBENCH created designs are provided AS IS without warranty of any kind for evaluation and testing purposes and are subject to the terms of the [Evaluation License Agreement](#).